



SERVING
SAFETY



Mors Smitt Railway Technology Miniature circuit breakers

Hydraulic magnetic



SERVING
SAFETY

Mors Smitt Railway Technology

Miniature circuit breakers



Always striving to be the best

Miniature circuit breakers



Mors Smitt offers a wide range of railway hydraulic magnetic circuit breakers. The circuit breakers are fully configurable to meet the individual requirements.

Advantages

- Precise, temperature stable mechanism, due to hydraulic magnetic technology
- Overcurrent sensing mechanism reacts only to changes of current
- No 'warm-up' period to slow down its response to overload. No 'cooldown' period after overload before it can be reset. Derating considerations due to temperature variations are not normally required and heat-induced nuisance tripping is avoided
- A common trip linkage between all poles, another safety feature, ensures that an overload in one pole will trip all adjacent poles
- A trip-free mechanism, a safety feature, makes it impossible to manually hold the contacts closed during overcurrent or fault conditions
- Standard dimensions, mounting and current ratings provide maximum application versatility
- Wide range: current ratings to 125 Amps and rated voltages to 600 VAC and 110 VDC are available
- Options: series trip, mid-trip, switch only (with or without auxiliary switch), remote shutdown, shunt trip, and dual coil circuit options are available

Standards

The Mors Smitt miniature circuit breakers are designed according the following railway standards:

IEC 60077	Electrical equipment for rolling stock in railway applications
EN 50155	Electronic equipment used on rolling stock for railway applications
EN 45545-2	Fire protection on railway vehicles
NF F16-101/-102	Fire behavior - Railway rolling stock
IEC 61373	Shock & vibration resistance - Railway rolling stock



Utrecht, September 2010

Mors Smitt continuous to improve its products and services. Specifications are changed without prior notice. No rights can be derived from specifications in this brochure. Changes and printed errors reserved.

Features

Time delays

A wide range of time delays is available for optimal application compatibility.

Accessories

A wide range of accessories is available for flexible connectivity. E.G. busbars and feeding terminals.

Hydraulic magnetic

Operation is precise and not affected by changes in ambient temperatures.

Trip-free mechanism

This safety feature makes it impossible to manually hold the contacts closed during over-current or fault conditions.

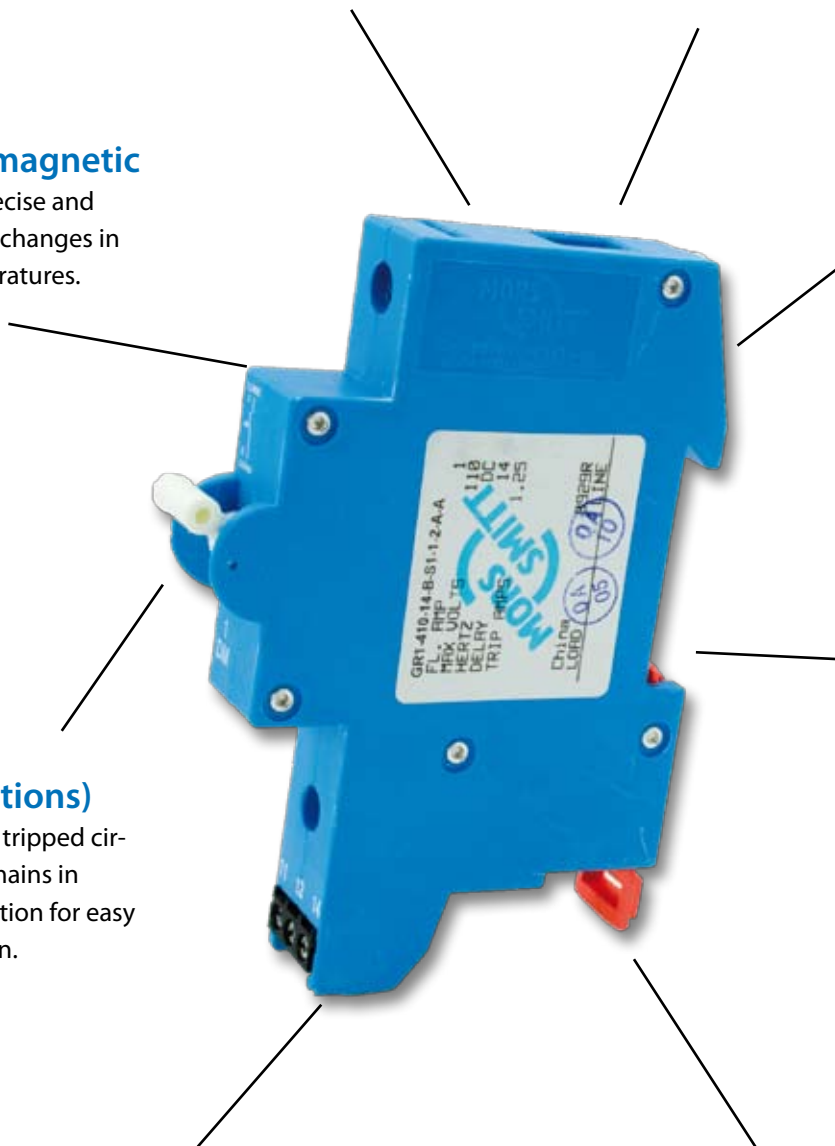

Mid trip (handle options)

The handle of a tripped circuit breaker remains in the middle position for easy visual inspection.

Circuit options

Several circuit options are available for easy adaption in any application.

Auxiliary contacts

The auxiliary switch presents the status of the circuit breaker and can be connected to external electronics, e.g. annunciators on a drivers desk.

Connection terminals

All Mors Smitt circuit breakers can be equipped with a terminal of your choice, to save installation time.

What makes a magnetic circuit breaker trip

Standard configuration

The most common magnetic circuit breaker configuration is called 'Series trip'. It consists of a current sensing coil connected in series with a set of contacts (figure 1).

Rated current or less

Inside the coil is a non-magnetic delay tube, housing a springbiased, moving, magnetic core. An armature links the contacts to the coil mechanism, which functions as an electro magnet. When the contacts are open, there is no current flow through the circuit breaker, and no electro-magnetic energy is developed by the coil. When the contacts are closed, current flow begins (figure 2).

Moderate overload with induced delay

As the normal operating or 'rated' current flows through the sensing coil, a magnetic field is created around that coil. When the current flow increases, the strength of the magnetic field increases, drawing the springbiased, movable, magnetic core toward the pole piece. As the core moves inward, the efficiency of the magnetic circuit is increased, creating an even greater electro-magnetic force. When the core is fully 'in', maximum electro-magnetic force is attained, the armature is attracted to the pole piece, unlatching a trip mechanism, thereby opening the contacts (figure 3).

Short circuit condition no induced delay

Under short circuit conditions, the resultant increase in electro magnetic energy is so rapid, that the armature is attracted without core movement, allowing the breaker to trip without an induced delay. This is called 'instantaneous trip'. It is a safety feature which results in a very fast trip response when most needed (figure 4).

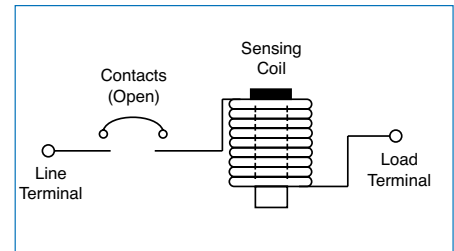

Figure 1 - Standard configuration

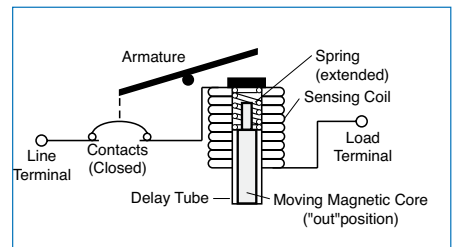

Figure 2 - Rated current or less

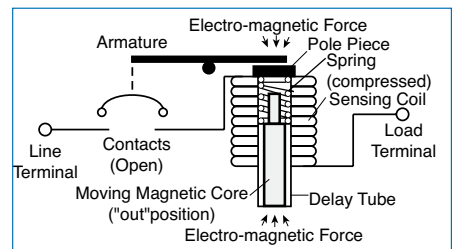

Figure 3 - Moderate overload with induced delay

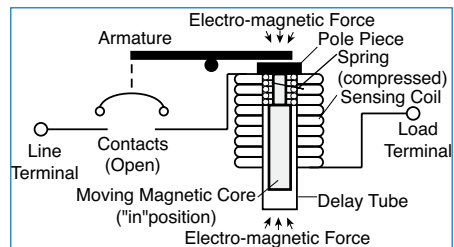

Figure 4 - Short circuit condition no induced delay

Circuit options

Available circuit options

Series trip

A basic two terminal device is usually used as a combination power switch and overload protector. the contacts and current sensing coil are connected in series with the line and load terminals (figure 1).

Series trip with auxiliary switch

Same as a series trip except with the addition of a S.P.D.T. snap-action switch, which is electrically isolated, but mechanically linked to the movement of the main breaker contacts. This switch is commonly used to remotely signal the status of the breaker (on or off / tripped) (figure 2). Series trip is also available with alarm switch.

Series mid-trip with alarm switch

Similar to 'Series trip with auxiliary switch' except the S.P.D.T. auxiliary switch is actuated only upon electrical trip of the breaker. upon electrical trip, the NO contact closes and the NC contact opens. This can be used to remotely signal the tripped status of the breaker. also, upon electrical trip, the handle moves to the 'mid' position as opposed to the 'full off' position typical of other breakers. This gives a specific visual panel indication of a tripped breaker as compared to one which is merely turned off (figure 2). Series mid-trip is also available without auxiliary switch.

Series trip with remote shutdown

For dump circuit or panic circuit applications. Same as a series trip but with an additional (self-interrupting) voltage coil pole (usually of opposite polarity) for remote shutdown. In the example, a momentary voltage pulse to pole 2 will shut down both pole 1 and pole 2. Because the voltage coil in pole 2 is self-interrupting, no additional components, such as auxiliary switches, are required in that circuit (figure 3).

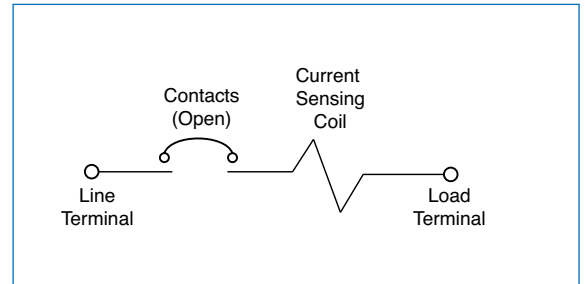

Figure 1 - Series trip

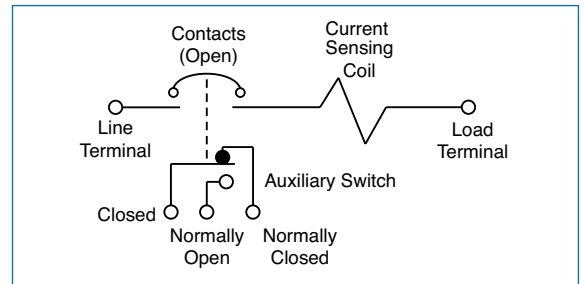

Figure 2 - Series trip with auxiliary switch

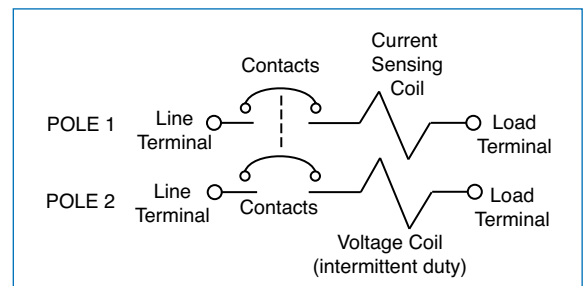

Figure 3 - Series trip with remote shutdown

Dual coil with remote shutdown

Similar to 'Series trip with remote shutdown' except an extra pole is not required. A dual coil breaker has two coils in the space normally occupied by a single coil. A current coil is used for overload protection and the instant trip voltage coil can be used for remote shutdown. The dual coil option is the 'shunt trip dual coil', a three terminal device with one side of the voltage coil internally connected to the primary circuit (figure 4). The other side of the voltage coil is connected to an external third terminal on the bottom of the breaker. This circuit option uses line voltage for dual coil activation, saving wiring costs and resulting in a self-protecting voltage coil.

Switch only

Same as a series trip, but without a sensing coil. Provides low cost, heavy-duty switch capability when overload protection is not needed. 'Switch only' is available with and without an auxiliary switch (figure 5).

Shunt trip

A three terminal device similar to 'Series trip', but with the addition of a third terminal between the contacts and the coil. This circuit is usually used to control two separate loads (a&b) from the same power source, while sensing overload current in only one load (b). It should be noted that overload protection is not provided in the load (a) circuit, and if needed, must be provided by other means. Also, the sum of the current in circuit a & b must not exceed the contact rating of the device (figure 6).

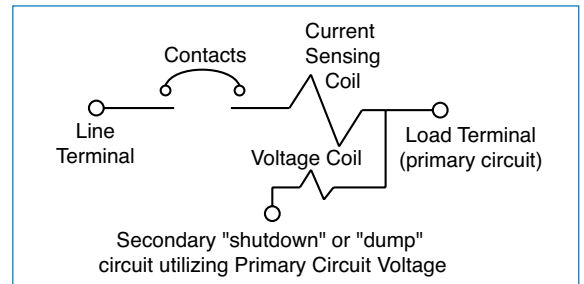

Figure 4 - Shunt trip dual coil

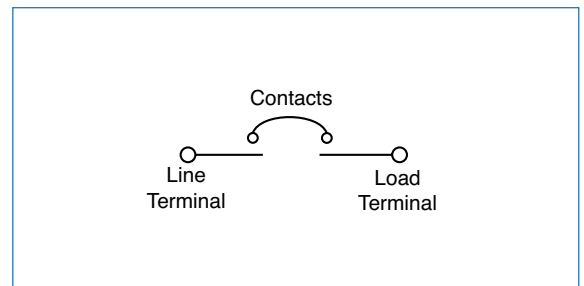

Figure 5 - Switch only

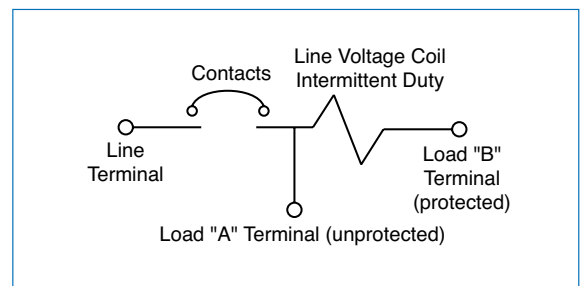

Figure 6 - Shunt trip

Time delays

The trip time of a hydraulic magnetic circuit breaker is directly related to the length of time it takes for the moving metal core to move to the full 'in' position.

If the delay tube is filled with air, the core will move rather quickly, and the breaker will trip quickly. This is characteristic of the ultrashort delay curves (figure 1).

Solid state devices, which cannot tolerate even short periods of current overload, should use Instantaneous curves (figure 2).

These curves have no intentional time delay. When the delay tube is filled with a light viscosity (temperature stable) fluid, the core's travel to the full 'in' position will be intentionally delayed. This results in the slightly longer medium delays (figure 3), which are used for general purpose applications.

When a heavy viscosity fluid is used, the result will be a long delay, such as figure 4. These curves are commonly used in motor applications to minimize the potential for nuisance tripping during lengthy motor start-ups.

By use of magnetic 'shunt' plates within the magnetic circuit, it is possible to divert magnetic flux resulting in higher 'inrush withstanding capability' (or high inrush delays). These delays disregard short duration, high pulse surges (typically 8ms or less and up to 25x rated current), characteristic of transformers, switching power supplies and capacitive loads (figure 5).

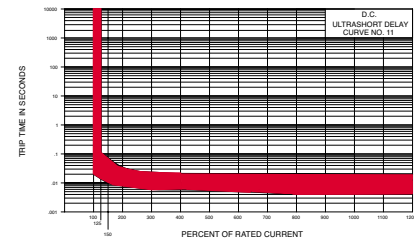

Figure 1 - Ultrashort delay curve

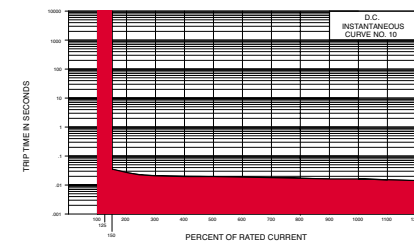

Figure 2 - Instantaneous curve

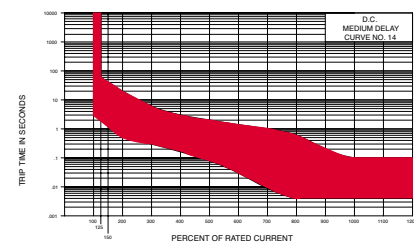

Figure 3 - Medium delay curve

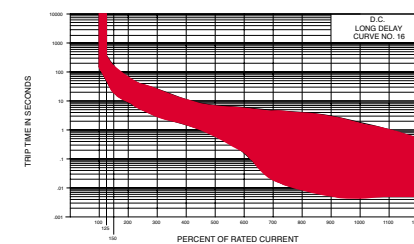

Figure 4 - Long delay curve

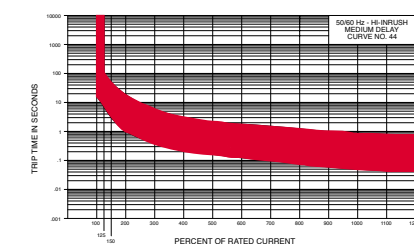

Figure 5 - Hi-inrush medium delay curve

Customized solutions

Perfect solutions

New built or retro-fit Mors Smitt will deliver a perfect and competitive on time solution for any onboard challenge of space limitations and / or technical requirement. In close co-operation with customers, the best configuration of power distribution, protection components such as miniature circuitbreakers, relays and contactors will be selected to get the optimum result.

Application examples:

GFI (Ground fault detection)

For the London Sub Surface Line (SSL) Mors Smitt designed a GFI unit (Ground fault indicator). The GFI unit works together with a circuit breaker equipped with an additional voltage coil and detects unbalances between the 3 phases and ground. The GFI unit is connected to the voltage coil of the circuit breaker. When the voltage coil is energized the breaker will trip. When the GFI senses an unbalance the unit will trip the circuit breaker to disconnect application from the power supply to prevent any damage to the application.



Remote operated circuit breaker

Applications along the trackside are often on a big distance from the controlroom, so when a fault occurs the circuit breaker will trip and someone needs to go to the site to check and switch the installation back on again. A time consuming, expensive operation causing long unnecessary downtime on the track for instance. Upon a failure just check the status and switch the MCB back on as tripping maybe caused by nuisance and not real problems. For ProRail in the Netherlands Mors Smitt designed a solution to control circuit breakers remotely.

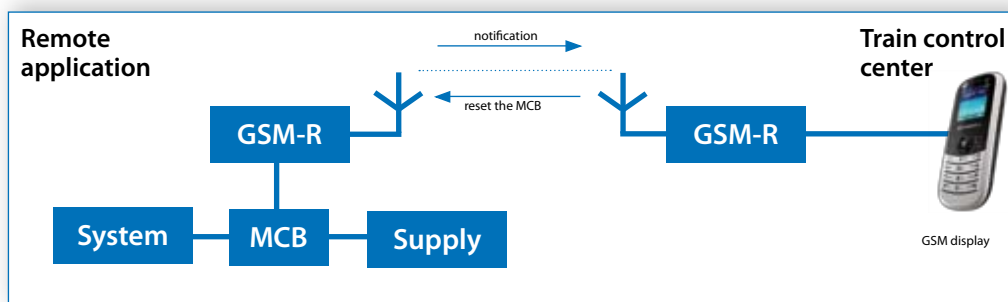

Reference projects

Sub Surface Line (SSL) - London

Together with Bombardier Transportation special electric power distribution panels (AC & DC) have been developed. A smart mechanical construction was designed for easy assembly and access under the seats in the train to optimize use of limited space . A construction was selected where the earth leakage module is combined with circuit breakers to guarantee optimum user safety.



For this project (2009 - 2015) a total of 32.000 Mors Smitt circuit breakers are used in 2.792 panels.

SEPTA Philadelphia

Especially for SEPTA Philadelphia Mors Smitt designed a solution with key points like low maintenance, plug and play installation and two sides accessible. Hyundai Rotem and Mors Smitt selected a configuration with circuit breakers, D-U relays and contactors in a square electrical distribution panel.









For this project (2008 - 2011) a total of 7.600 Mors Smitt circuit breakers are used in 120 panels.

Selection table



Series overview

						
	AR series	CR series	GR series	ER series	RBR series	PDR series
Overcurrent protection	✓	✓	✓	✓	✓	
Remote operated					✓	
Ground fault protection						✓
Rated current	0.1 to 50 A	0.02 to 100 A	0.2 to 63 A	0.1 to 125 A	0.02 to 100 A	0.1 to 50 A
Panel mounting	✓	✓		✓ *	✓	
Wall mouning				✓ *		
35 mm rail mounting			✓			✓
** Max. nominal voltage DC	80	110	110	110	110	-
** Max. nominal voltage AC	227	415	440	600	415	480
Max. number of poles	6	6	4	6	3	4
Auxiliary or alarm contact available	✓	✓	✓	✓	✓	
See page	14	16	18	20	22	24

* Panel or wall mounting

** All specifications according to railway standards see specific datasheets for details.

Product range

AR Series



Panel mounting Up to 6 poles

- Compact design
- Unique arc chute method which results in higher interrupting capacities
- Thermoset glass filled polyester halfshell construction for increased mechanical strength, electrical strength and to achieve highest level / rating on fire and smoke tests
- Standard blue housing and white handle to improve visibility
- Precise, temperature independent, operation
- Wide choice of time delays, terminal options and actuator colors
- The breakers can also be equipped with an optional mid-trip handle style actuator

Electrical characteristics

Maximum nominal voltage	277 VAC 50/60 Hz, -10%/+10%, 80 VDC -30%/+25% (specifications according to railway standards)
Current ratings	0.1 - 50 A (other ratings on request)
Standard voltage coils	6 VDC ... 65 VDC & 6 VAC ... 240 VAC
Auxiliary switch ratings	SPDT; 10.1 A - 250 VAC, 1.0 A - 65 VAC, 0.5 A - 80 VDC, 0.1 A - 125 VAC (with gold contacts)
Insulation resistance	Minimum 100 Megohms at 500 VDC
Dielectric strength	1500 V 60 Hz for one minute between all electrically isolated terminals
Max. interrupting capability	3000 A @ 65 VDC 3500 A @ 65 VDC (with fuse backup) 3000 A @ 250 VAC 5000 A @ 277 VAC (with fuse backup)

Dimensions

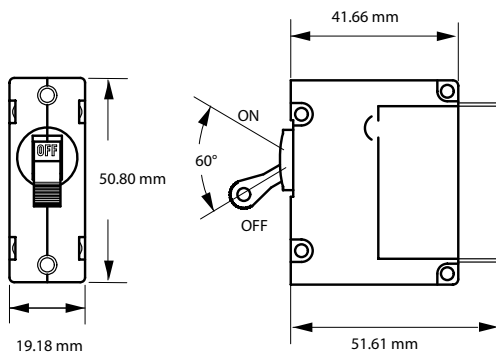

Mechanical characteristics

Endurance	10.000 On-off operations @ 6 per minute; with rated current & voltage
Trip free mechanism	All AR series circuit breakers will trip on overload, even when the actuator is forcibly held in the on position
Mid trip indication (optional)	The operating actuator moves positively to the off position when an overload causes the circuit breaker to trip. When mid-trip handle is specified, the handle moves to the mid position on electrical trip of the circuit breaker. When mid-trip handle with alarm is specified, the handle moves to the mid position & the alarm actuates when the circuit breaker is electrically tripped.

Terminals



Faston / tab 6.3 mm



Double faston / tab 6.3 mm
+ aux. switch



Stud M6

Other terminals available. See AR series datasheets.

Handle



Small handle



On and off switch



Black handle



Red handle

Other colours available. See AR series datasheets.

Physical characteristics

Number of poles	1 - 6 poles at 30 Amps or less. 1 and 2 poles at 31 Amps thru 50 Amps
Internal circuit	Series (with or without auxiliary switch), shunt with current or voltage trip coil
Configuration	Dual coil, switch only with or without auxiliary switch
Weight	Approx. 65 g/pole. (2.32 ounce)
Colours	Housing - blue, actuator - white with dual legends

Environmental characteristics

Operating temperature	-50 °C...+85 °C
Vibration, functional	IEC 61373, section 8, table 1, category 1, class B, body mounted MIL-STD-202G Method 204C
Shock	NF F62-001, par 11.4.2 IEC 61373, par 10, table 3 MIL-STD-202G
Salt spray	IEC 60068-2-52
Damp heat	IEC 60068-2-3D
Fire and smoke	NF F16-101/102
Response time at different temperature	NF F62-001

Product range

CR Series



Panel mounting Up to 6 poles

- Unique arc chute design which results in higher interrupting capacities
- Thermoset glass filled polyester halfshell construction for increased mechanical strength, electrical strength and to achieve highest level/rating on fire and smoke tests
- Wiping contacts - mechanical linkage with two-step actuation – cleans contacts, provides high, positive contact pressure & longer contact life
- Standard blue housing and white handle to improve visibility
- Available with metric threaded stud terminals and american standard terminals
- The breakers can also be equipped with an optional mid-trip handle style actuator
- 0.02 - 100 amps
- Precise, temperature independent, operation

Electrical characteristics

Maximum nominal voltage	AC: 277 VAC, -10%/+10% (single pole), 415 VAC, -10%/+10% (multiple pole) DC: 110 VDC, -30%/+25% (single and multiple pole) (Specifications according to railway standards)
Current ratings	0.02 - 100 A (other ratings on request)
Standard voltage coils	6 VDC - 65 VDC / 6 VAC - 240 VAC (other ratings on request)
Auxiliary switch ratings	110 VDC - 0.1A; 96 VDC - 0.3 A; 72 VDC - 0.75 A; 36/48 VDC - 1 A ; 24 VDC - 1.5 A; 12 VDC - 2 A; 120/240/250 VAC - 0.1 A
Insulation resistance	Minimum 100 Megohms at 500 VDC
Dielectric strength	5000 V 50/60Hz for one minute between all electrically CR series circuit breakers comply with the 8 mm spacing requirements from hazardous voltage to operator accessible surfaces, between adjacent poles and from main circuit to auxiliary circuits.

Dimensions

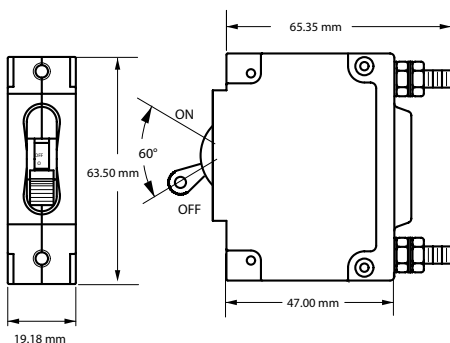

Mechanical characteristics

Endurance	20,000 On-off operations @ 6 per minute without current & voltage and 10,000 On-off operations with rated current & voltage
Trip free mechanism	Trips on short circuit overload, even when actuator is forcibly held in the On position.
Mid trip indication (optional)	The operating handle moves positive to the mid position and an auxiliary switch is actuated when an overload causes the circuit breaker to trip.

Terminals



Stud M5 or M6



Stud M5 or M6 + aux. switch



Shrouds (IP 20 protection)



Plug-in

Other terminals available. See CR series datasheets.

Handles



Small handle



On and off switch



Black handle



Red handle

Other colours available. See CR series datasheets.

Physical characteristics

Number of poles	AC application voltage: 1 - 2 poles \leq 100 A 3 - 4 poles \leq 70 A 5 - 6 poles \leq 50 A	DC application voltage: 1 pole \leq 100 A 2 - 6 poles \leq 70 A
Internal circuit	Trip switch only Trip with auxiliary switch Mid-trip Mid-trip with alarm switch Mid-trip w/auxiliary switch	Switch only w/auxiliary switch Shunt trip current coil Shunt trip voltage coil Relay trip (current) Relay trip (voltage)
Weight	Approx. 112 g/pole (3,95oz)	
Colours	Housing - blue, actuator - white with dual legends	
Material	Half shells - BMC605 Handle - Valox 420SEO UL94VO Terminals - Brass with acid tin plate	

Environmental characteristics

Operating temperature	-50 °C...+85 °C
Vibration, functional	IEC 61373, section 8, table 1, category 1, class B, body mounted MIL-STD-202G Method 204C
Shock	NF F62-001, par 11.4.2 IEC 61373, par 10, table 3 MIL-STD-202G
Salt spray	IEC 60068-2-52
Thermal shock	MIL method 107D, condition A
Damp heat	IEC 60068-2-3D
Fire and smoke	NF F16-101/102
Response time at different temperature	NF F62-001
Protection level	IP40 when mounted in a panel

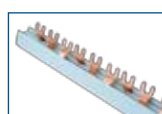

Busbar



Endcap



Terminal

See page 26 for accessories for these circuit breakers.

Terminal

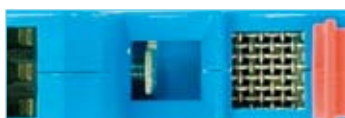

Box terminals with pressure plate

Physical characteristics

Number of poles	1, 2, 3 or 4 poles
Termination	Line or load terminal: dual connection. Maximum wire size 35 mm ² flexible, 50 mm ² rigid. Busbar/tab connection thickness range 1.19 ~ 1.57 mm (0.047 ~ 0.062 inch). Different wire sizes in one terminal is not recommended.
Max. torque value of terminals	2.26 Nm (Line and load)
Auxiliary contacts	Captive screws. Maximum wire size ~ 1.5 mm ²
Mounting	35 mm rail. Lock is located at bottom of circuit breaker (load terminal side) when mounted vertical.
Configuration	Series trip & switch only
Dimensions (w)	17.48 mm

Environmental characteristics

Operating temperature	-50 °C...+85 °C
Vibration, long life	IEC 61373, section 9, table 1, category 1, class B, bodymounted
Vibration, functional	IEC 61373, section 8, table 1, category 1, class B, bodymounted.
Shock	NF F62-001, par 11.4.2 IEC 61373, par 10, table 3, category 1, classes A & B, body mounted.
Salt spray	IEC 60068-2-52
Thermal shock	MIL-STD 202G method, condition A (5 cycles @ -55 °C...+25 °C to +85 °C...+25 °C)
Damp heat	IEC 60068-2-3D, test method Db, variant 1
Fire and smoke	NF F16-101/102, DIN 5510 & BS6853
Response time at different temperature	NF F62-001
Protection level	IEC 60529; IP20 and IP40
Moisture resistance / humidity	MIL-STD 202G method, i.e. 24 hour cycles @ +25 °C...+60 °C, 80-90% RH

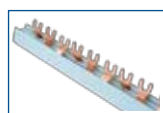

Busbar



Endcap



Terminal

See page 27 for accessories for these circuit breakers.

Product range

ER Series



Higher voltage & current Up to 6 poles

- Ideal for higher amperage applications
- Available with front and back mounting
- Heavy duty box wire connector for solid wire and a pressure plate connector for stranded wire
- Unique arc chute design, which results in higher interrupting capacities
- Thermoset glassfilled polyester halfshell construction for increased mechanical strength, electrical strength and to achieve highest level / rating on fire and smoke tests
- Wiping contacts, mechanical linkage with two-step actuation, cleans contacts, provides high, positive contact pressure & longer contact life
- Standard blue housing and white handle to improve visibility
- Precise, temperature independent, operation
- Large choice of time delays

Electrical characteristics

Maximum nominal voltage	AC: 277 VAC, 90% -10%/+10% (single pole), 415 VAC, -10%/+10% (multiple pole) DC: 110 VDC, -30%/+25% (single and multiple pole) (specifications according to railway standards)
Current ratings	Standard current coils: 0.100, 0.250, 0.500, 1.00, 2.50, 5.00, 7.50, 10.0, 15.0, 20.0, 25.0, 30.0, 50.0, 60.0, 70.0 & 100 Amp
Auxiliary switch ratings	SPDT; 10.1 A - 250 VAC, 1.0 A - 65 VAC, 0.1 A - 125 VDC, 0.5 A - 80 VDC, 0.1A - 125 VAC (with gold contacts)
Insulation resistance	Minimum 100 Megohms at 500 VDC
Dielectric strength	2200 V 50/60Hz for one minute between all electrically isolated terminals. ER-series circuit breakers comply with the 8 mm. spacing and 3750 V 50/60 Hz dielectric requirements from hazardous voltage to operator accessible surfaces, between adjacent poles and from main circuit to auxiliary circuits
Max. interrupting capability	5000 A @ 125 VDC 6000 A @ 240 VAC

Dimensions

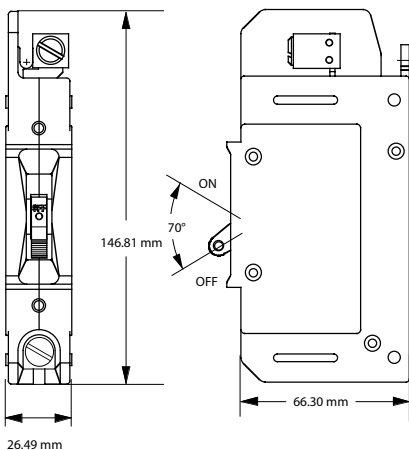

Mechanical characteristics

Endurance	20.000 On-off operations @ 6 per minute without rated current & voltage and 10.000 On-off operations with rated current & voltage
Trip free mechanism	All ER series circuit breakers will trip on overload, even when the actuator is forcibly held in the on position
Trip indication	Standard trip indication, the operating actuator moves positively to the off position when an overload causes the breaker to trip.

Terminals



Box terminals



Stud M6

Many other terminals available.
See ER series datasheets.

Physical characteristics

Number of poles	1 - 6 poles
Mounting	A 7.62 mm (3") minimum spacing must be provided between the circuit breaker arc venting area on back connecting ER series circuit breakers and grounded obstructions. ER series circuit breakers must be mounted on a vertical surface.
Connectors, box type	Front connected ER series circuit breakers are supplied with box type pressure connectors that accept copper or aluminium conductors as follow: 1/0 - 14 copper, 1/0 - 12 aluminium.
Internal circuit	Series and switch only (with or without auxiliary switch), shunt with current coil
Configuration	Dual coil, switch only with or without auxiliary switch
Weight	Approx. 252 g/pole. (9 ounce)
Colours	Housing - blue, actuator - white with dual legends
Material	Half shells – BMC605 Handle – Valox 420SEO UL94VO Terminals – Brass with acid tin plate

Environmental characteristics

Operating temperature	-50 °C...+85 °C
Vibration, functional	IEC 61373, section 8, table 1, category 1, class B, body mounted, MIL-STD-202G Method 204C
Shock	NF F62-001, par 11.4.2, IEC 61373, par 10, table 3, MIL-STD-202G
Salt spray	MIL-STD 202G method 101, test condition A
Thermal shock	MIL method 107D, condition A
Damp heat	IEC 60068-2-30, test method Db, Variant 1
Fire and smoke	NF F16-101/102
Response time at different temperature	NF F62-001, paragraph 11.3.2 / 11.3.4 / 11.3.5
Protection level	IP40 when mounted in a panel

Product range

RBR Series



Remote operated Up to 3 poles

- On / off and trip indication
- Load shedding
- Energy management
- Compact size
- Automatic reset capable
- Choice of interface styles
- Panel mounting
- Manual operation override
- Fits into industry standard cut-out

The RBR series remote operated circuit breaker combines the convenience of remote on, off and reset capability with the safety and accuracy of a standard magnetic current sensing device.

Thus allowing operation of the breaker from various locations in a system, facility or site (while not sacrificing the ability to manually operate the breaker if required). With the RBR service, diagnostics, load shedding and power distribution control functions can now be performed in areas that were previously unattended, inaccessible or unsafe.

The RBR module allows remote operation of CR series panelmount breakers, (up to 3 poles) through hard wiring with a single pole, double throw switch connected to a standard power source, or more sophisticated relay and modem networks.

Electrical characteristics

Maximum nominal voltage	AC: 277 VAC, -10%/+10% (single pole), 415 VAC, -10%/+10% (multiple pole) DC: 110 VDC, -30%/+25% (single and multiple pole) (specifications according to railway standards)
Current ratings	0.02 - 100 A (other ratings on request)
Auxiliary switch ratings	110 VDC - 0.1 A; 96 VDC - 0.3 A; 72 VDC - 0.75 A; 36/48 VDC - A; 24 VDC - 1.5 A; 12 VDC - 2 A; 120/240/250 VAC - 0.1 A
Insulation resistance	Minimum 100 Megohms at 500 VDC
Dielectric strength	3750 V 50/60Hz for one minute between all electrical CR series circuit breakers comply with the 8 mm spacing requirements from hazardous voltage to operator accessible surfaces, between adjacent poles and from main circuit to auxiliary circuits.

Dimensions

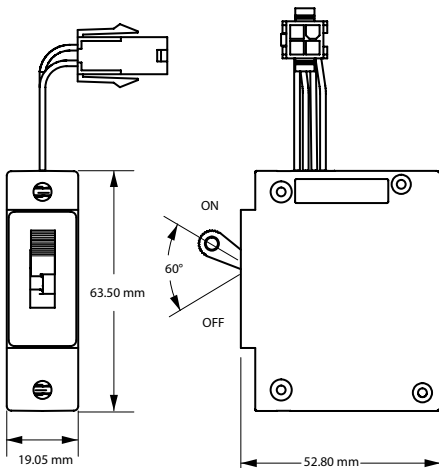

Mechanical characteristics

Endurance	20,000 On-off operations @ 6 per minute without current & voltage and 10,000 On-off operations with rated current & voltage
Trip free mechanism	Trips on short circuit overload, even when actuator is forcibly held in the On position.
Mid trip indication (optional)	The operating handle moves positive to the mid position and an auxiliary switch is actuated when an overload causes the circuit breaker to trip.

Terminals



Stud M5 or M6



Stud M5 or M6 + aux. switch

Many other terminals available.
See RBR series datasheets.

RBR motor specifications

Interface options	- Flying leads - Integral connector - Flying lead with 4 pin dual row connector
Voltage input	12 VDC, 20-40 VDC, 41-80 VDC
Start current	< 1 A
Switching time	< 2 s

Physical characteristics

Number of poles	Up to 3 poles
Internal circuit	Series trip, switch only, shunt trip
Weight	
Colours	Housing - blue, actuator - white with dual legends
Material	Half shells – BMC605 Handle – Valox 420SEO UL94VO Terminals – Brass with acid tin plate

Environmental characteristics

Operating temperature	-50 °C...+85 °C
Vibration, functional	IEC 61373, section 8, table 1, category 1, class B, body mounted MIL-STD-202G Method 204C
Shock	NF F62-001, par 11.4.2 IEC 61373, par 10, table 3 MIL-STD-202G
Salt spray	IEC 60068-2-52
Thermal shock	MIL method 107D, condition A
Damp heat	IEC 60068-2-3D
Fire and smoke	NF F16-101/102
Response time at different temperature	NF F62-001
Protection level	IP40 when mounted in a panel

Product range

PDR Series



Equipment leakage Up to 3 poles

- Blue housing
- 1-3 poles plus neutral
- 7-100 mA
- Precise, temperature independent operation
- Choice of time delays, terminals and actuator colours

Electrical characteristics

Maximum voltage	AC 480 WYE / 277 VAC, 50/60 Hz
Current ratings	1.00, 2.50, 5.00, 7.50, 10.0, 15.0, 20.0, 25.0, 30.0, 35.0, 40.0 & 50.0 Amps (other ratings on request)
Insulation resistance	Minimum: 100 Megohms at 500 VDC
Dielectric strength	1960 VDC, 60 Hz for one minute between all electrically isolated terminals from line to load terminal (values based on series trip circuit breaker)

Leakage to ground

Standard must trip leakage current ratings	7, 10, 15, 30, 50 & 100 milli Amps (other ratings on request)
Trip time	300 ms max. @ 100%, 40 ms max. @ 500% of must trip leakage current.
Test button	On breaker face above actuator.
Leakage trip indicators	Red LED on breaker face above actuator

Dimensions

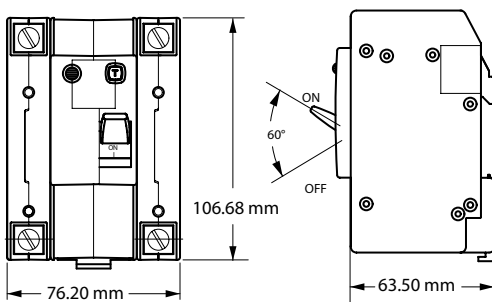

Mechanical characteristics

Endurance	10.000 On-off operations @ 6 per minute; with rated current & voltage
Trip free mechanism	All PDR series circuit breakers will trip on overload, or leakage to ground, even when the actuator is forcibly held in the on position

Terminal options



Box terminals

Physical characteristics

Number of poles	2, 3 & 4 poles
Internal circuit	Series trip
Mounting	Front panel or standard 35 mm rail
Termination	Box lug
Dimensions (l x w x d)	2 pole: 106.7 x 76.2 x 63.5 mm (4.2 x 3.0 x 2.5 inch) 3 pole: 106.7 x 95.3 x 63.5 mm (4.2 x 3.75 x 2.5 inch) 4 pole: 106.7 x 114.3 x 63.5 mm (4.2 x 4.5 x 2.5 inch)
Weight	2 pole: 453 g (16 oz.) 3 pole: 606 g (21.4 oz.) 4 pole: 762 g (26,9 oz.)
Colours	Housing - blue, actuator - white with dual legends

Environmental characteristics

Operating temperature	-10 °C...+50 °C
Vibration, functional	IEC 61373, section 8, table 1, category 1, class B, body mounted MIL-STD-202G Method 204C
Shock	NF F62-001, par 11.4.2 IEC 61373, par 10, table 3 MIL-STD-202G
Salt spray	IEC 60068-2-52
Thermal shock	MIL method 107D, condition A
Damp heat	IEC 60068-2-30
Fire and smoke	NF F16-101 / 102
Response time at different temperature	NF F62-001
Protection level	IP40 when mounted in a panel

Product range

Accessoires

CR series circuit breakers

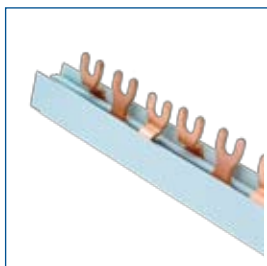

Busbar up to 80 A, fork type, 1m

Article numbers	Phase	Poles
631312152	1	52
631312252	2	52
631312351	3	51



Feeding terminal, external, fork type

Article number:
631910001

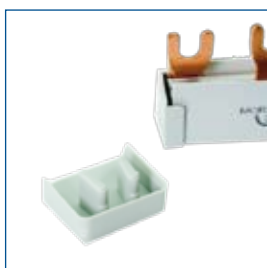

Endcap for busbar, fork and pin, 16 mm²

Article numbers	Phase
631912160	1
631912360	2 & 3

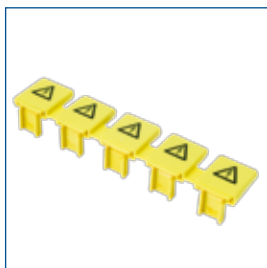

Touch protection, to cover free busbar connectors, yellow (1004), set of 5 caps

Article number
631910000



Corner shaped busbar, 1 phase, 63 A

Article number	Poles	Article number	Poles
631311102	2	631311110	10
631311103	3	631311111	11
631311104	4	631311112	12
631311105	5	631311153	53
631311106	6		
631311107	7		
631311108	8		
631311109	9		



Handle lock with locking ring

Article numbers	Colour
631310001	Red
631310002	Black
631312003	White

Accessoires

GR series circuit breakers

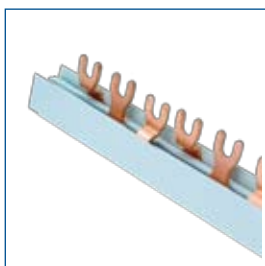

Busbar up to 63 A, fork type, 1m

Article numbers:	Phase	Poles
631911256	2	56
631911357	3	57

Busbar up to 80 A, fork type, 1m

Article numbers:	Phase	Poles
631912157	1	57
631912256	2	56
631912357	3	57
631912456	4	56



Feeding terminal, external fork, insulated

Article number:
631910001



Endcap for busbar (fork and pin, 10 mm²)

Article numbers:	Phase
631911260	2
631911360	3

Endcap for busbar (fork and pin, 16 mm²)

Article numbers:	Phase
631912160	1
631912360	2&3
631912460	4



Feeding terminal, external pin, insulated

Article numbers:
631910002 Short pin
631910003 Long pin

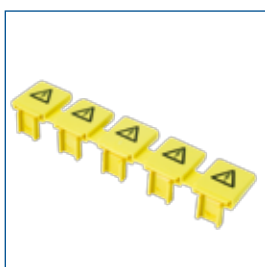

Touch protection, to cover free busbar connectors, yellow (1004), set of 5 caps

Article number:
631910000



Feeding terminal, external pin, insulated

Article number:
631910004 Side connected

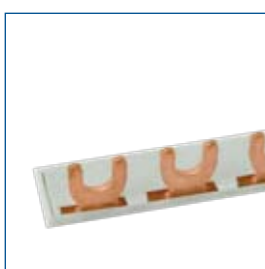

Single phase corner shaped busbar, 63 A

Article number:	Poles
631911163	3
631911164	4
631911165	5
631911166	6
631911167	7
631911168	8
631911169	9
631911170	10
631911171	11
631911172	12



Feeding terminal, external pin, insulated

Article number:
631910005 Screw connected,
with 3 front connectors



Handle lock

Article number: Colour
631910007 Aluminium



Busbar feeding terminal, connects stranded wires to busbar

Article number:
631910006 Side by side,
stackable

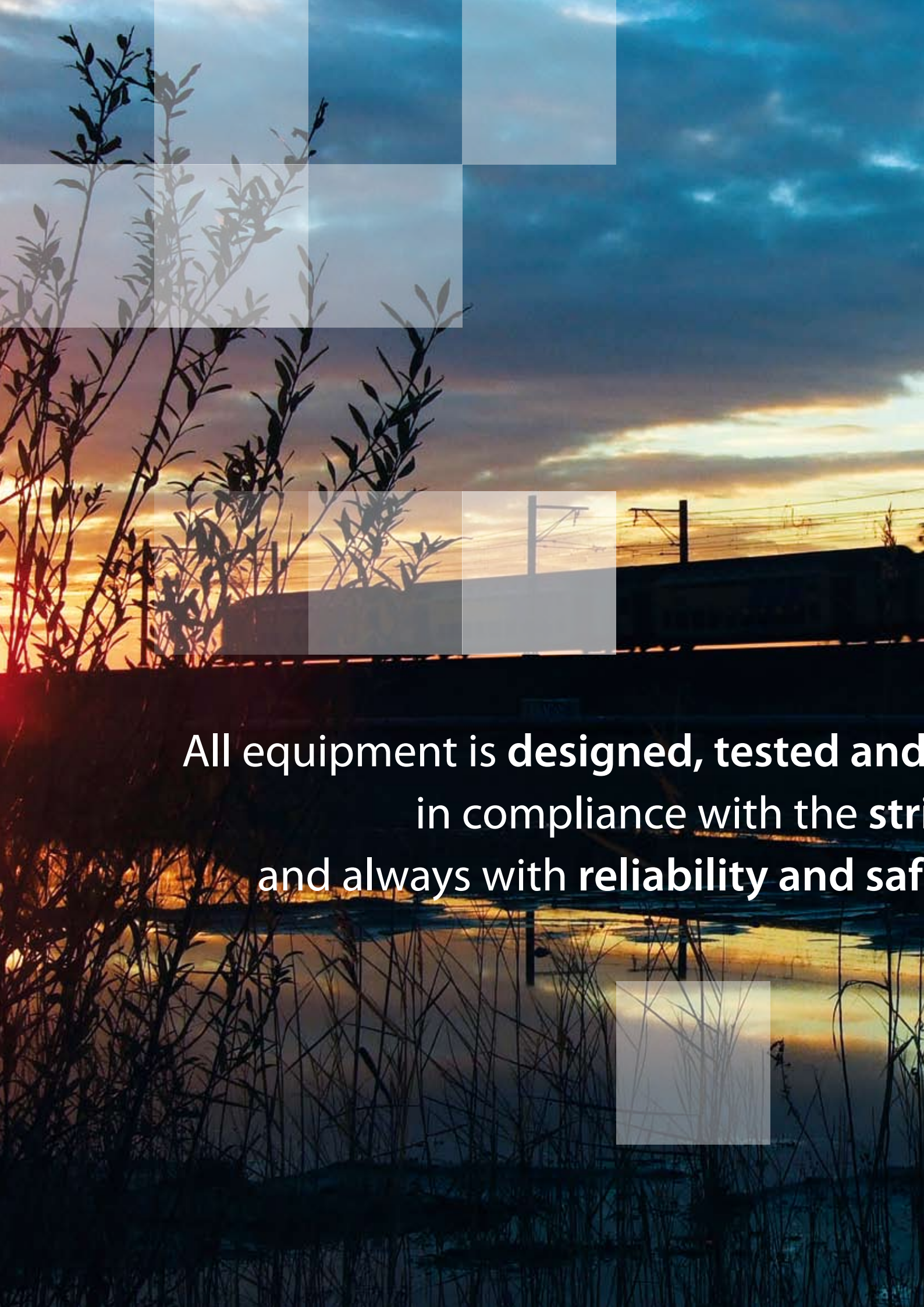
The background is a composite image. The top half shows a sunset sky with orange and yellow light transitioning into a deep blue. Silhouetted plants are in the foreground. A train is visible in the middle ground, moving from left to right. The bottom half shows a body of water reflecting the sunset, with reeds in the foreground.

All equipment is designed, tested and
in compliance with the strict
and always with reliability and safety



SERVING
SAFETY

manufactured
strictest international standards
safety in the front of our mind



SERVING
SAFETY

Mors Smitt Railway Technology

Miniature circuit breakers

SALES OFFICES

FRANCE

MS Relais SAS

Tour Rosny 2, Avenue du Général de Gaulle

F - 93118 Rosny-sous-Bois Cedex, France

T +33 (0)1 4812 1440

F +33 (0)1 4855 9001

E sales@msrelais.com

HONG KONG

Mors Smitt Asia Ltd.

807, Billion Trade Centre, 31 Hung To Road

Kwun Tong, Kowloon, Hong Kong SAR

T +852 2343 5555

F +852 2343 6555

E info@morssmitt.hk

THE NETHERLANDS

Nieaf-Smitt B.V.

Vrieslantlaan 6

3526 AA Utrecht, The Netherlands

T +31 (0)30 288 1311

F +31 (0)30 289 8816

E sales@nieaf-smitt.nl

USA

Mors Smitt Technologies Inc.

420, Sackett Point Road

North Haven, CT 06473, USA

T +1 203 287 8858

F +1 888 287 8852

E mstechnologies@msrelais.com

Your local contact:

BRO-MCB-V1.2-0411

www.morssmitt.com

