



1M122A User Guide

Transformer Parallel Control System

RMS Mors Smitt

Advanced Protection Devices



1M122A Parallel Control System



User Guide

1M122A User Guide

About This Manual

This User Guide covers all 1M122A relays manufactured from May 2026. Earlier relays do not necessarily incorporate all the features described. Our policy of continuous may means that extra features & functionality may have been added.

The 1M122A User Guide is designed as a generic document to describe the common operating parameters for all relays built on this platform.

The copyright and other intellectual property rights in this document, and in any model or article produced from it (and including any registered or unregistered design rights) are the property of RMS Mors Smitt. No part of this document shall be reproduced or modified or stored in another form, in any data retrieval system, without the permission of RMS Mors Smitt, nor shall any model or article be reproduced from this document without consent from RMS Mors Smitt.

While the information and guidance given in this document is believed to be correct, no liability shall be accepted for any loss or damage caused by any error or omission, whether such error or omission is the result of negligence or any other cause. Any and all such liability is disclaimed.

Contact Us

RMS Mors Smitt

19 Southern Court • Keysborough 3173 • AUSTRALIA

Phone +61 3 8544 1200

Email sales.rms@wabtec.com • Web <http://www.morssmitt.com/rms>

Contents

CONTENTS	3
OVERVIEW	5
DESCRIPTION OF OPERATION	6
TYPICAL SYSTEM CONFIGURATION	7
COMMUNICATIONS BUS	7
<i>Single Transformer Installation</i>	8
<i>Adding a Second Transformer</i>	8
<i>Follower Only Operation</i>	8
<i>Adding a Third & Fourth Transformer</i>	8
1X200 TRANSFORMER CONTROL PANEL	9
1X200 Push Button Controls	10
OFF Mode	10
MANUAL Mode.....	10
MANUAL RAISE and LOWER Taps.....	11
AUTO INDEPENDENT Mode.....	12
AUTO MASTER Mode	13
AUTO FOLLOWER Mode.....	14
REMOTE CONTROL Mode.....	14
<i>Remote Tap Raise and Tap Lower</i>	15
1X200 Repeat Status Output Contacts.....	16
DESCRIPTION OF OPERATING MODES.....	16
<i>Operating Configuration Example 1</i>	17
<i>Operating Configuration Example 2</i>	18
<i>Operating Configuration Example 3</i>	19
<i>Operating Configuration Example 4</i>	20
<i>Operating Configuration Example 5</i>	21
<i>Operating Configuration Example 6</i>	22
TAP POSITION INDICATION.....	23
<i>Tap Position Indicator Failure</i>	24
TECHNICAL BULLETINS	25
SOFTWARE FUNCTION	26
FACTORY DEFAULT SOFTWARE.....	26
DETERMINING SOFTWARE UMX.....	26
USER INTERFACE	26
INSTALLATION.....	27
HANDLING OF ELECTRONIC EQUIPMENT	27
SAFETY SECTION	28
EXPLANATION OF SYMBOLS & LABELS	28
UNPACKING	29
ACCESSORIES.....	30
STORAGE & HANDLING	30
EQUIPMENT OPERATING CONDITIONS.....	31
RECOMMENDED MOUNTING.....	31
19 INCH RACK MOUNTING	31
FLUSH PANEL MOUNTING.....	32

SCHEME WIRING	33
DISTRIBUTED SCHEME	33
CENTRALIZED SCHEME	34
RECOMMENDED CUBICLE WIRING SCHEME	35
EQUIPMENT CONNECTIONS.....	36
TERMINATION RING LUGS.....	37
<i>Ring Lug Dimensions</i>	37
<i>Ring Lugs without 90 Degree Pre-form</i>	38
<i>Rear Terminal Arrangement</i>	39
<i>Wiring Diagram</i>	40
<i>Step by Step Wiring Guide</i>	41
Step 1: Transformer Control System Configuration.....	41
Step 2: 1M122A Rack External Connections (Mandatory).....	42
Step 3: 1M122A Rack External Connections (Application Specific)	43
Step 4: Bus Wiring (Inter scheme Bus Wiring)	47
2V200 Tap Position Transducer Connections.....	48
2V200 Tap Position Transducer Wiring Interface	48
RELAY SETTING	50
CRITICAL SETTINGS	50
<i>Critical 2V164 Settings (umx2V164I_XXXX)</i>	51
<i>Critical 2V165 Settings (umx2V165C_XXXX)</i>	55
<i>Application Note – Using Mixed Tap Position Indicator Transducer Types</i>	59
COMMISSIONING.....	62
COMMISSIONING PRELIMINARIES	62
<i>Earthing</i>	62
<i>Insulation</i>	62
COMMISSIONING TESTS.....	63
DANGER	63
<i>Relay CT shorting switches</i>	63
<i>Primary injection testings</i>	63
PRE SITE COMMISSIONING SCHEME VERIFICATION CHECKLIST.....	64
TRANSFORMER OFF LOAD CHECKS	70
TRANSFORMER ON LOAD CHECKS	72
DECOMMISSIONING & DISPOSAL	72
MAINTENANCE	73
MECHANICAL INSPECTION.....	73
<i>Relay Assembly</i>	73
<i>Relay Module</i>	73
<i>Relay Case</i>	74
<i>Test Intervals</i>	74
DEFECT REPORT FORM.....	75

Overview

This User Guide covers all 1M122A relay versions & describes the generic features & attributes common across all versions.

Different relay versions are required to cater for varying customer requirements such as auxiliary voltage range, I/O configuration, case style, relay functionality etc.

2V164-S uMATRIX platform relay that provides the voltage regulating functionality



2V165-S uMATRIX platform relay that provides the parallel control functionality



Description of Operation

The 1M122A Parallel Control System is a complete solution for the control of up to four (4) transformers in either independent or parallel mode or in any combination using the proven master / follower technique.

Each transformer is fitted with an identical 1M122A Parallel Control System which is then configured to link with a specific transformer - 1 to 4 - with hard wired links. The 1M122A units communicate with one another over a hard wired BUS for simplicity, reliability and ease of expansion.

Using the integrated 1X200 Transformer Control Panel on each 1M122A, the transformer mode – OFF, MANUAL, AUTO or REMOTE - may be set at the front panel or via SCADA using the appropriate status input.

The 1M122A comprises 3 main elements which are supplied fully configured & wired in 19" sub rack frames ready for integration into each transformer control panel.

Each 1M122A sub rack comprises:

- ◆ a 1X200 Transformer Control Panel;
- ◆ a 2V164 AVR;
- ◆ a 2V165 Parallel Control Relay.

All units are draw out modules allowing simple changeover in the unlikely event of failure or system re-configuration.

1X200
Transformer
Control
panel
2V164-S
Voltage
regulator
2V165-S
Parallel
Control
unit

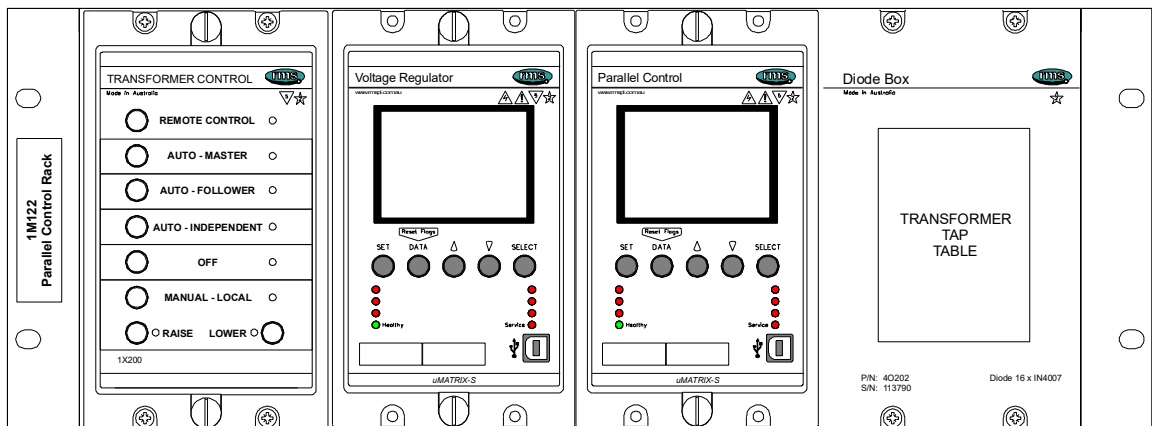

Typical System Configuration

The typical system configuration depicted below allows for the control of up to four (4) transformers in either independent or parallel mode using a master / follower scheme.

Transformers should ideally be matched to minimize circulating currents.

Typical System Configuration for up to four (4) transformers

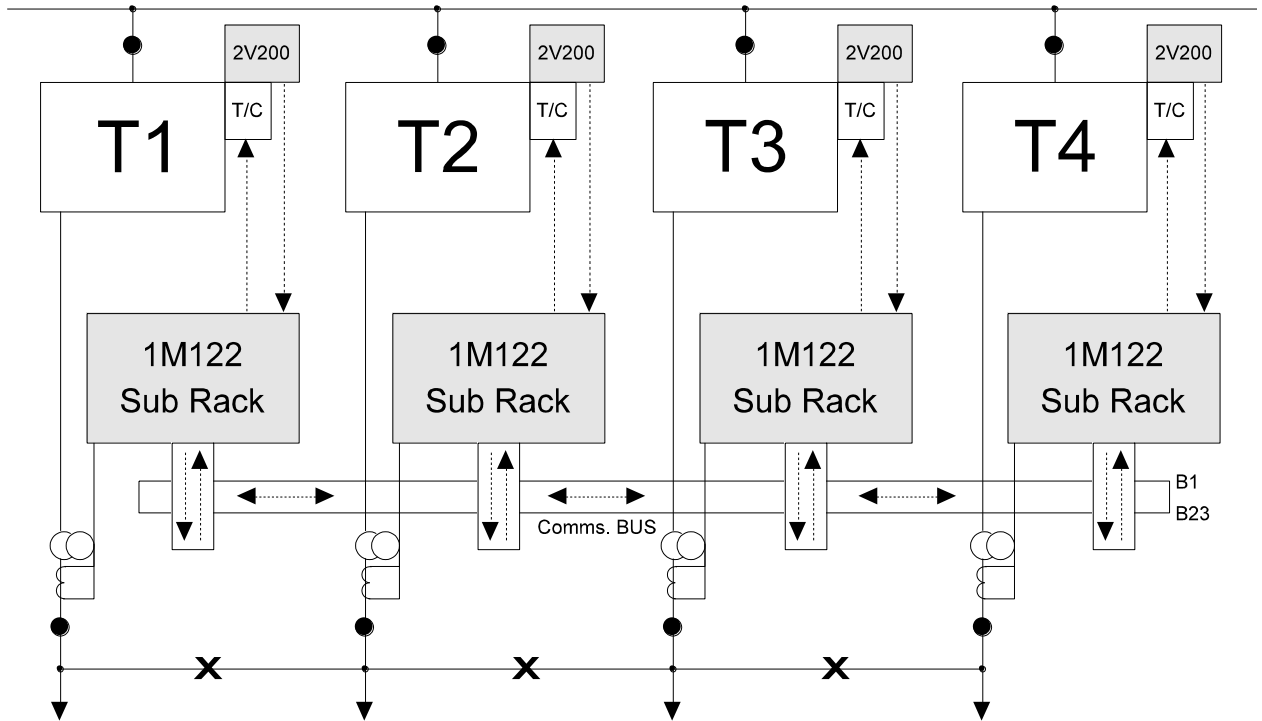

Communications BUS

A 1M122A is required for each transformer control cubicle. Signalling between each 1M122A is accomplished via a conventional hard wired BUS for simplicity, flexibility & reliability. The number of wires in the communications BUS is determined by the number of parallel transformers:

No. Transformers	Number of Communications BUS wires
1	-
2	13
3	18
4	23

Single Transformer Installation

A single 1M122A may be used in a stand alone transformer installation. In this instance it will not be operated in MASTER or FOLLOWER mode & so the 2V165 Parallel Control Relay may be omitted & a 1X300 Follower Module fitted to save cost.

Adding a Second Transformer

The addition of a second transformer is achieved by simply connecting the communications BUS wiring to the second control cubicle. At least one 2V165 Parallel Control Relay is required & may be fitted into the new 1M122A or swapped with the 1X300 in the existing 1M122A. Alternatively both 1M122A sub racks may have a 2V165 installed in which case either transformer can be set as the MASTER with a single button operation or SCADA control input to the 1X200.

Follower Only Operation

Where a transformer is required to operate in FOLLOWER mode only, the 2V164 AVR may also be omitted & replaced with a 1X400 Follower Module.

Where a 1X400 is fitted the 2V165 serves no function & may be replaced with a 1X300.

Adding a Third & Fourth Transformer

Up to four (4) transformers may be connected on the communications BUS. These may then be set to operate in parallel, independently or in any combination bearing in mind that for a transformer to be set to MASTER it must have both a 2V165 & 2V164 relay fitted.

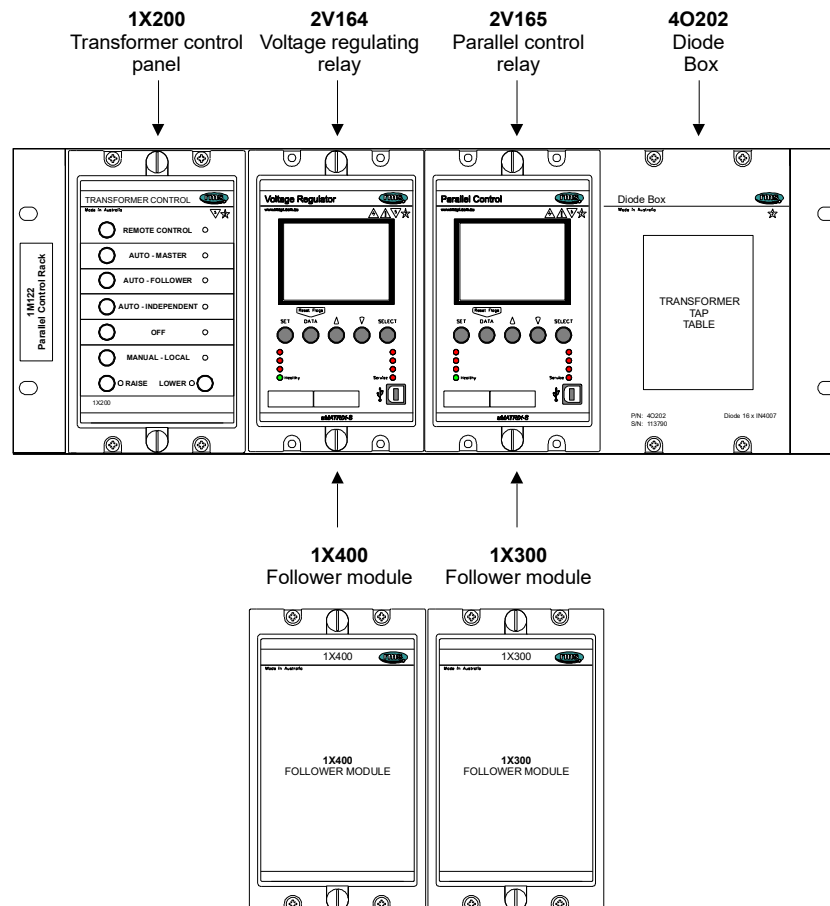

These modules may be fitted in place of the 2V164 & 2V165 in accordance with the schemes depicted in diagrams 1 - 6.

1X200 Transformer Control Panel

Each transformer is interfaced to a specific 1M122A control system. The 1M122A must be configured as being connected to transformer 1, 2, 3, or 4 using hard wire links as described in the section on scheme rack wiring.

Each 1M122A has a 1X200 control panel which is used to select and display the transformer operating mode.

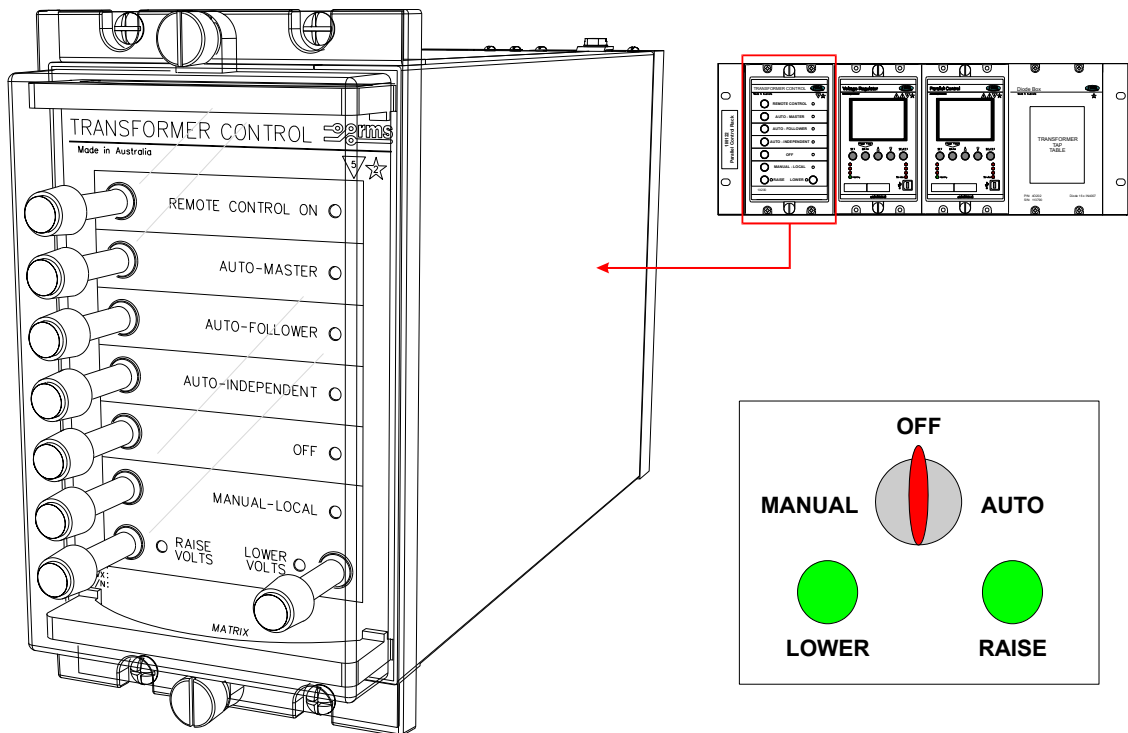

The 1X200 Transformer Control Panel is used to replicate the function of a traditional MANUAL – OFF – AUTO selector switch.

The following section describes the 1X200 controls and operating modes.

1X200 Push Button Controls

Push buttons are provided to select the required mode of operation.

Momentary depression of a button will select the required mode of operation and the associated LED will illuminate.

OFF Mode

- When the system is powered up the 1X200 will default to the OFF mode.
- All voltage control outputs and associated alarms are disabled in the OFF mode.
- REMOTE CONTROL cannot be selected using the remote status input when in OFF mode.
- Safety interlocks are built in such that MANUAL and REMOTE tap raise and lower command inputs are inhibited when the OFF position is selected.

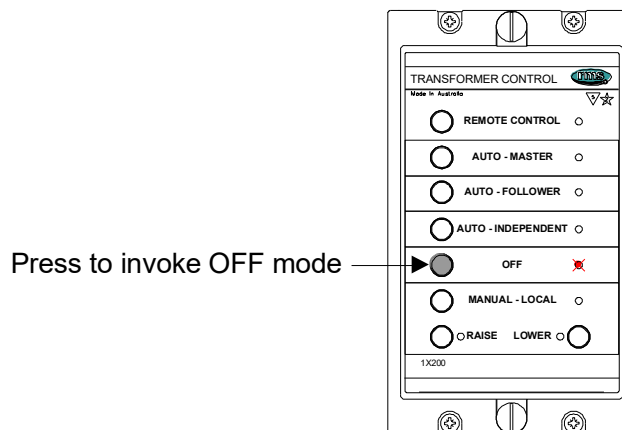

MANUAL Mode

- This mode is used to manually change the tap position of the transformer.
- The MANUAL mode can only be selected from the OFF mode.
- The RAISE VOLTS and LOWER VOLTS buttons are only active in MANUAL mode.
- REMOTE CONTROL cannot be selected using the remote status input when in MANUAL mode.

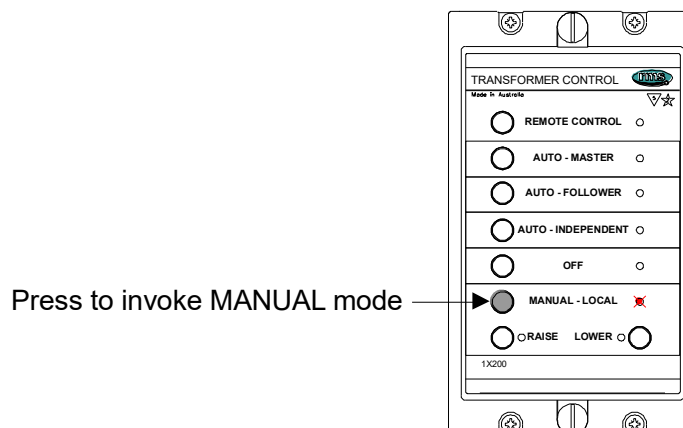

MANUAL RAISE and LOWER Taps

- The RAISE VOLTS and LOWER VOLTS buttons are only active in MANUAL mode.

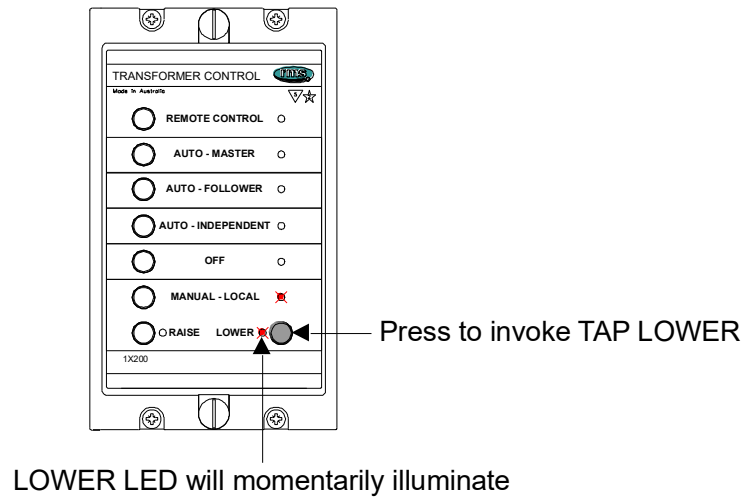
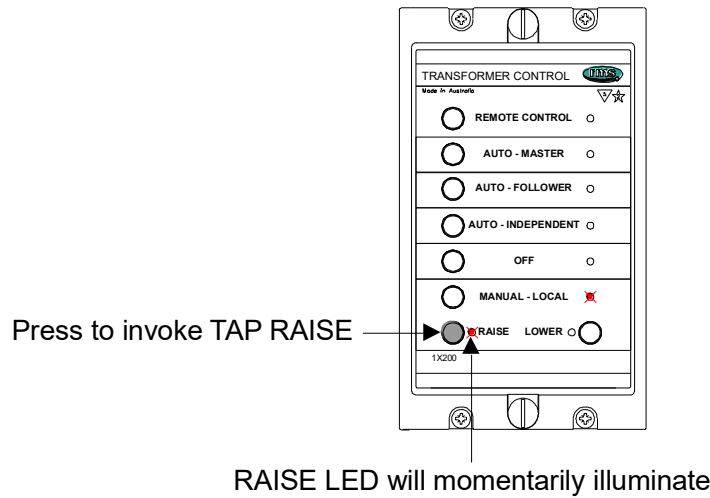

AUTO INDEPENDENT Mode

- This mode is used when the transformer is required to operate independently of other transformers that may be connected on the scheme.
- The 2V164 AVR in the 1M122A control system will send tap change commands via the 1X200 control panel to maintain voltage regulation in accordance with the applied control settings.
- Whilst in any of the other AUTO modes the AUTO INDEPENDENT mode is selected directly.
- If the scheme is not already in AUTO mode, say after a manual raise or lower operation, the controller must first be placed in the OFF state and then AUTO INDEPENDENT mode is selected.
- The AUTO INDEPENDENT mode cannot be selected from MANUAL mode.

Press to invoke AUTO INDEPENDENT mode

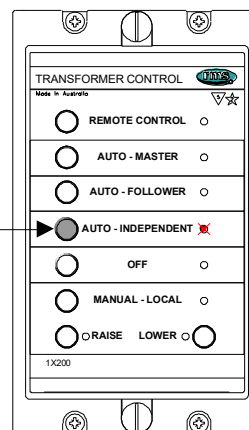

AUTO MASTER Mode

- This mode is used when multiple transformers are to be controlled in parallel.
- The 1M122A system selected as AUTO MASTER will control 1M122A systems selected as AUTO FOLLOWER.
- The 2V164 AVR will send tap change commands to the 2V165 parallel control relay which will in turn convey these commands to those 1X200 control panels in AUTO mode.
- Whilst in any of the other AUTO modes the AUTO MASTER mode is selected directly.
- If the scheme is not already in AUTO mode, say after a manual raise or lower operation, the controller must first be placed in the OFF state and then AUTO MASTER mode is selected.
- The AUTO MASTER mode cannot be selected from MANUAL mode.

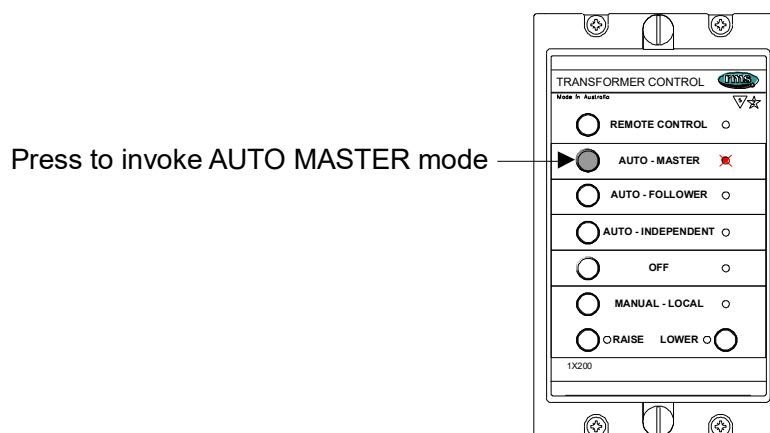

AUTO FOLLOWER Mode

- This mode is used when multiple transformers are to be controlled in parallel.
- The 1M122A system selected as AUTO FOLLOWER will be controlled by the 1M122A system selected as AUTO MASTER.
- Whilst in any of the other AUTO modes the AUTO FOLLOWER mode is selected directly.
- If the scheme is not already in AUTO mode, say after a manual raise or lower operation, the controller must first be placed in the OFF state and then AUTO FOLLOWER mode is selected.
- The AUTO FOLLOWER mode cannot be selected from MANUAL mode.

Press to invoke AUTO FOLLOWER mode

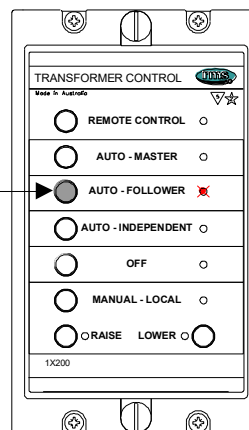

REMOTE CONTROL Mode

- This mode is selected when the transformer tap is to be changed remotely.
- REMOTE CONTROL mode may only be selected when one of the AUTO modes is invoked.
- When REMOTE CONTROL mode is invoked the LED for the previous AUTO mode will flash.
- Whilst in REMOTE CONTROL the other local AUTO modes may be selected directly, note that this action will revert the control to local mode and REMOTE CONTROL will need to be restored manually if required.
- The REMOTE CONTROL mode cannot be selected from MANUAL mode.
- Safety interlocks are built in such that MANUAL and REMOTE tap raise and lower command inputs are inhibited when the OFF position is selected.

Press to invoke
REMOTE CONTROL mode

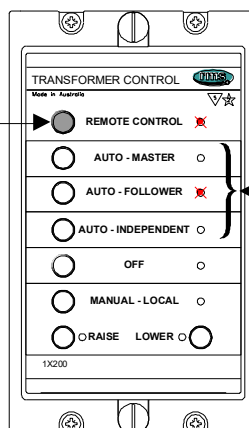

The previously active AUTO
mode LED will flash
indicating pending status

1X200 Remote Status Inputs

Remote status inputs are provided to select the required mode of operation via a SCADA system to:

- be placed in **REMOTE** control mode from any auto mode;
- be set to **AUTO - INDEPENDENT** from remote or auto mode;
- be set to **AUTO - FOLLOWER** from remote or master mode (note that Auto – Follower mode cannot be remotely selected from Auto – Independent mode, the 1M122A logic does however allow remote to be selected and then Auto – Independent mode);
- be set to **AUTO - MASTER** from remote or auto mode;
- be set to **OFF**.

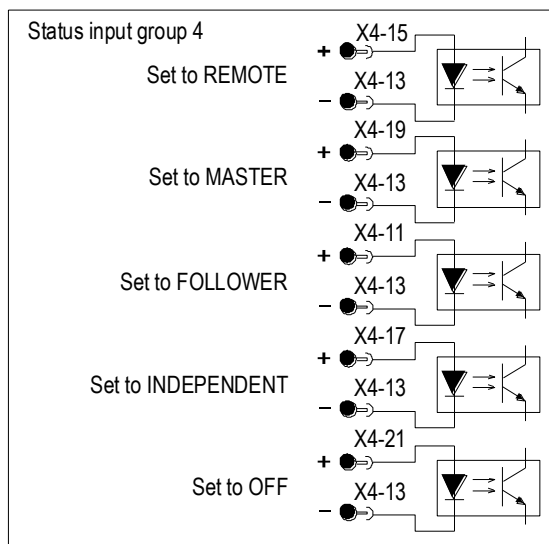

Momentary activation of a status input will select the required mode of operation and the associated LED will illuminate:

Remote Tap Raise and Tap Lower

Once placed in REMOTE mode clean contacts may be employed to manually raise or lower the tap position.

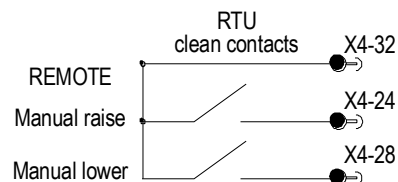

Note that REMOTE raise and lower commands may only be executed when FOLLOWER-REMOTE or MASTER-REMOTE modes are selected.

1X200 Repeat Status Output Contacts

A repeat output contact is also provided to signal the selected operating mode.

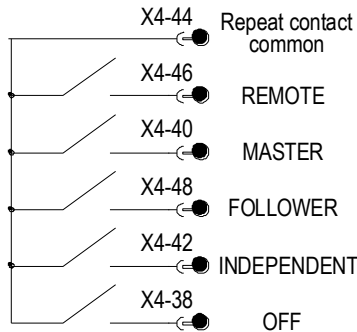

Description of Operating Modes

While the control of up to four (4) transformers is possible using the 1M122A system, the diagrams below are based on a three (3) transformer installation for simplicity.

The following diagrams depict the flow of tap change commands based on the mode of operation selected for each transformer at its 1X200 Control Panel.

Legend

X BUS tie open

 Tap raise / lower commands

 Power flow

 Isolator open

 2V165 Parallel Control
Not required for this configuration
1X300 may be fitted

 2V164 AVR
Not required for this configuration
1X400 may be fitted

Operating Configuration Example 1

All transformers are set to OFF or LOCAL - MANUAL.

All BUS ties & isolators are open.

No tap command issued.

Alarms inhibited.

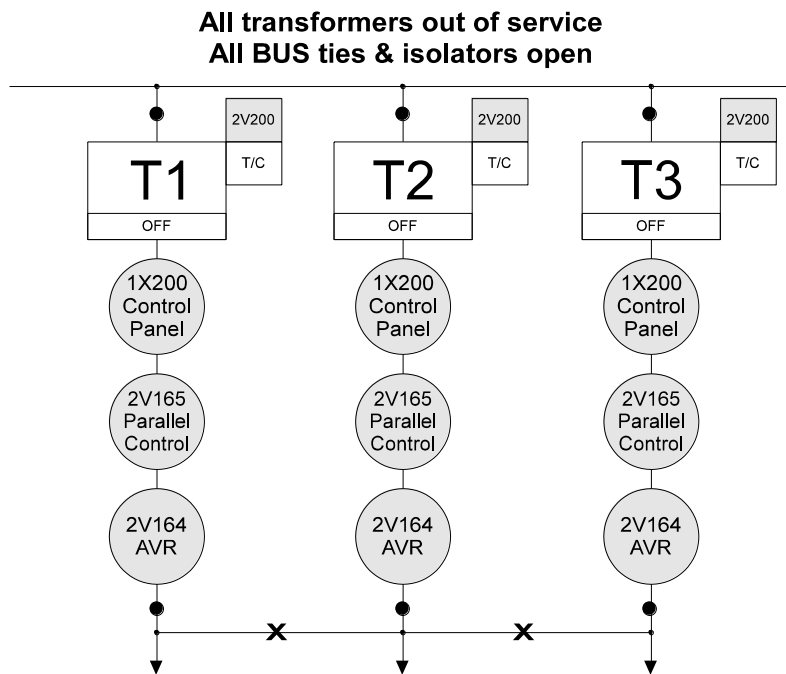

Operating Configuration Example 2

All transformers are set to AUTO - INDEPENDENT.

All BUS ties are open & isolators closed.

Each 2V164 AVR initiates AUTO tap raise & lower commands which are relayed through the 1X200 to the tap changer.

**T1, T2 & T3 operating independently
No MASTER control selected**

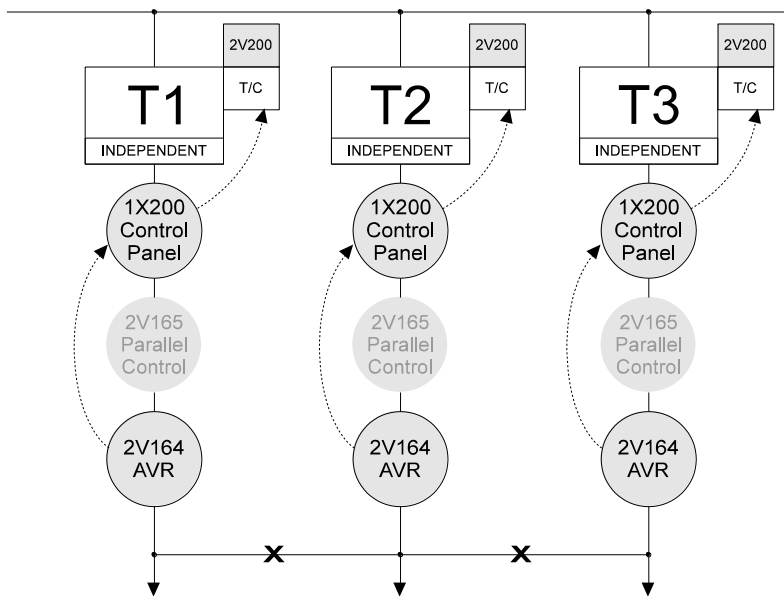

Operating Configuration Example 3

Transformer 1 is set to AUTO - FOLLOWER.

Transformer 2 is set to AUTO - MASTER.

Transformer 3 is set to AUTO - INDEPENDENT.

The BUS ties is closed between transformer 1 & 2.

All Isolators are closed.

The T2 2V164 initiates AUTO tap raise & lower commands which are relayed through the 2V165 to both the T1 & T2 1X200's & onto their respective tap changers.

T3 operates as per example 2.

T1 & T2 in parallel & T3 operating independently T2 selected as MASTER

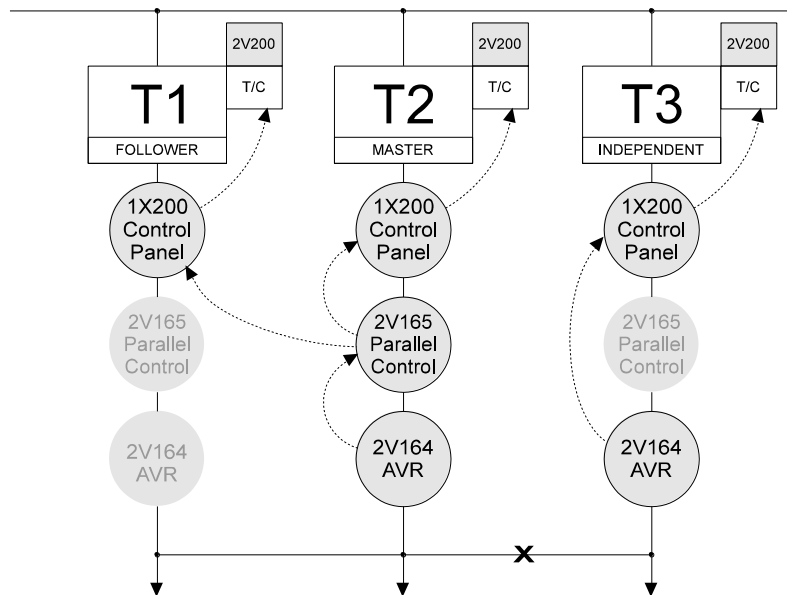

Operating Configuration Example 4

Similar to diagram 3 but this time:

Transformer 1 is set to AUTO - INDEPENDENT.

Transformer 2 is set to AUTO - FOLLOWER.

Transformer 3 is set to AUTO - MASTER.

The BUS tie is closed between transformer 2 & 3.

All isolators are closed.

The T3 2V164 initiates AUTO tap raise & lower commands which are relayed through the 2V165 to both the T2 & T3 1X200's & onto their respective tap changers.

T2 & T3 in parallel & T1 operating independently T3 selected as MASTER

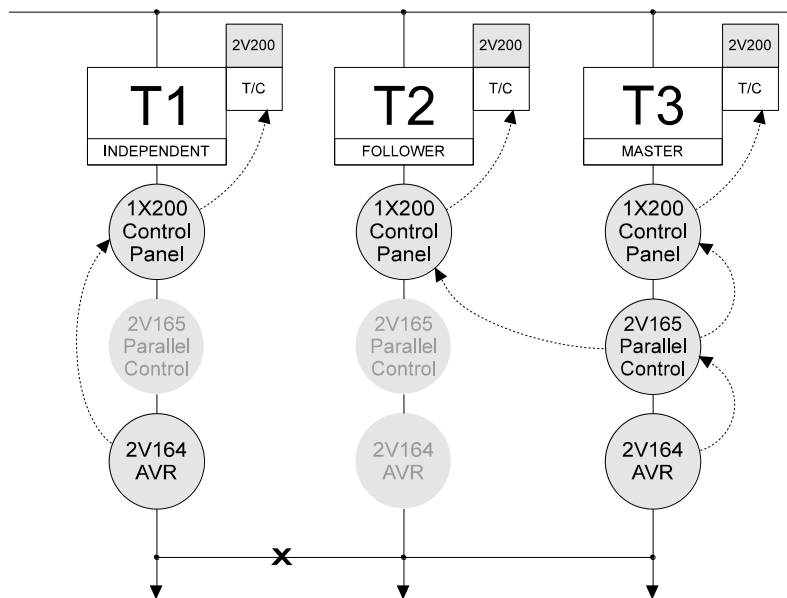

Operating Configuration Example 5

Transformer 1 is set to AUTO - FOLLOWER.

Transformer 2 is set to AUTO - MASTER.

Transformer 3 is set to AUTO - FOLLOWER.

All BUS ties & isolators are closed.

The T2 2V164 initiates AUTO tap raise & lower commands which are relayed through the 2V165 to the T1, T2 & T3 1X200's & onto their respective tap changers.

**T1, T2 & T3 operating in parallel
T2 selected as MASTER**

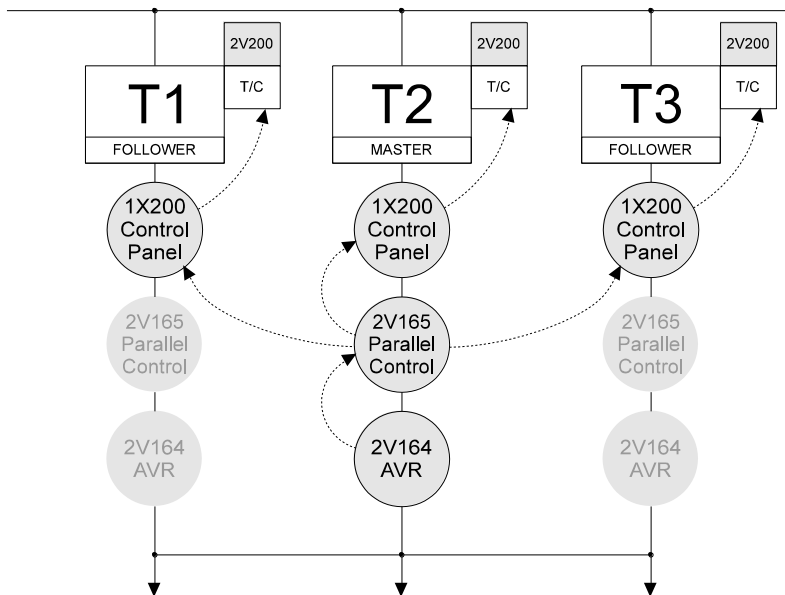

Operating Configuration Example 6

Similar to example 5 but this time:

Transformer 1 is set to AUTO - MASTER.

Transformer 2 is set to AUTO - FOLLOWER.

Transformer 3 is set to AUTO - FOLLOWER.

All BUS ties & isolators are closed.

The T1 2V164 initiates AUTO tap raise & lower commands which are relayed through the 2V165 to the T1, T2 & T3 1X200's & onto their respective tap changers.

**T1, T2, & T3 operating in parallel
T1 selected as MASTER**

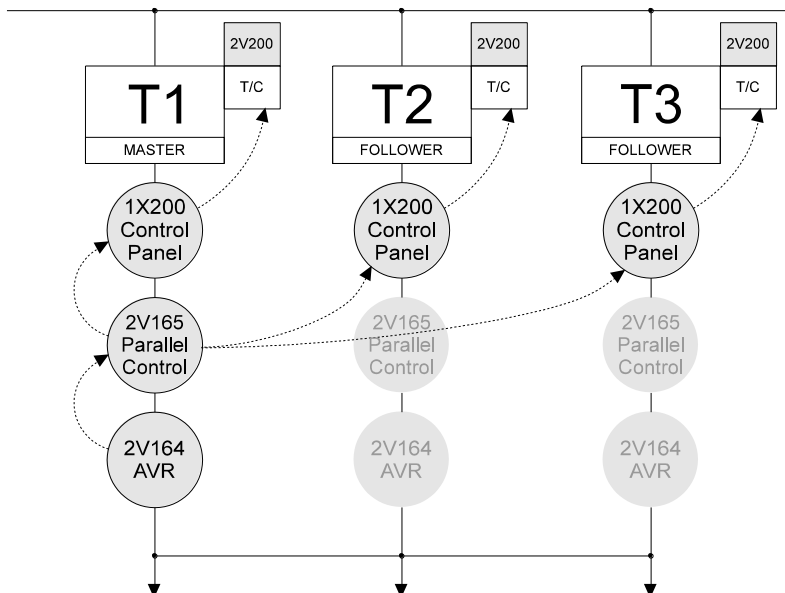

Tap Position Indicator Failure

The following summarises what the TPI Failure Detection algorithm does for each of the control modes:

Auto Master/Auto Follower

Any transformer in the Master/Follower group that develops a TPI failure will cause the master 2V165 to display a “TPI FAIL” message on the top line and operate the TPI Fail Alarm contact (common output with the Out of Step Alarm). The Tap Position of the transformer with the TPI failure will display a “TPI OFF LINE” message in place of the tap number.

The 2V164 of the transformer with the TPI failure condition will display a “TPI FAIL” message on the top line and the Tap Position will display a “TPI OFF LINE” message in place of the tap number and operate the TPI Fail Alarm contact (common output with the Tap Change Fail Alarm).

A TPI failure in a transformer group should be treated as an urgent alarm and attended to as soon as possible to avoid potential out of step conditions.

Auto Independent

A transformer operating in the Auto Independent mode that develops a TPI failure will cause all automated tap raise or tap lower commands to be blocked.

The 2V164 will display a “TPI FAIL” message on the top line and the Tap Position will display a “TPI OFF LINE” message in place of the tap number and operate the TPI Fail Alarm contact (common output with the Tap Change Fail Alarm).

Upon restoration of the TPI transducer signal, normal voltage regulation will resume.

Note that for 1M122A schemes that do not incorporate the maximum of 4 transformers, the 2V165 relays will display the “TPI OFF LINE” message in place of a tap number for the unused transformers.

Technical Bulletins

The detailed technical attributes, functional description & performance specifications for the 1M122A are described in the Technical Bulletin available from our website.

Specific details on the 2V164 & 2V165 relays used in the 1M122A are described in the respective Technical Bulletins available from our website.

Software Function

Factory Default Software

The 1M122A Parallel Control System is supplied with a default UMX so that it is ready for operation when received.

Determining Software UMX

Determining which UMX is loaded onto a μ MATRIX relay may be done in three ways:

1. New relays received from the factory have a label located on the side of the draw out module. This label is printed with information specific to the relay and includes the UMX type that was loaded during production.
2. Press the DATA and SET page buttons on the relay simultaneously to bring up the DIAGNOSTICS page.

Now press SELECT to view the versions page and you will see:

** VERSION PAGE **

BIOS Version: Vxx.xx	The version of the low level BIOS code loaded by the factory.
S/W Version: Vxx.xx	The version of the software UMX.
CBD: RMS Default	The .ump parameters file saved to the relay from μ MATRIXwin.
Model: xxxxxS	The xxxxx is the relay hardware code. The "S" is the UMX code.
S/N: xxxxxx.xx	The production tracking serial number also found on the front label.
H/W Config: xx	This number is related to the PCB loading and is auto detected.

3. Connect to the relay through the front panel USB configuration port using μ MATRIXwin and a PC. The UMX code & version is displayed at the bottom of the centre panel.

User Interface

Refer to the μ MATRIX Users Guide for detailed instructions on the operation of the user interface available on the website.

Installation

Handling of Electronic Equipment

A person's normal movements can easily generate electrostatic potentials of several thousand volts. Discharge of these voltages into semiconductor devices when handling electronic circuits can cause serious damage, which often may not be immediately apparent but the reliability of the circuit will have been reduced.

The electronic circuits of Relay Monitoring Systems Pty Ltd products are immune to the relevant levels of electrostatic discharge when housed in the case. Do not expose them to the risk of damage by withdrawing modules unnecessarily.

Each module incorporates the highest practicable protection for its semiconductor devices. However, if it becomes necessary to withdraw a module, the following precautions should be taken to preserve the high reliability and long life for which the equipment has been designed and manufactured.

1. Before removing a module, ensure that you are at the same electrostatic potential as the equipment by touching the case.
2. Handle the module by its front-plate, frame, or edges of the printed circuit board.
3. Avoid touching the electronic components, printed circuit track or connectors.
4. Do not pass the module to any person without first ensuring that you are both at the same electrostatic potential. Shaking hands achieves equipotential.
5. Place the module on an antistatic surface, or on a conducting surface which is at the same potential as yourself.
6. Store or transport the module in a conductive bag.

If you are making measurements on the internal electronic circuitry of an equipment in service, it is preferable that you are earthed to the case with a conductive wrist strap.

Wrist straps should have a resistance to ground between 500k – 10M ohms. If a wrist strap is not available, you should maintain regular contact with the case to prevent the build up of static.

Instrumentation which may be used for making measurements should be earthed to the case whenever possible.

Safety Section

This Safety Section should be read before commencing any work on the equipment.

The information in the Safety Section of the product documentation is intended to ensure that products are properly installed and handled in order to maintain them in a safe condition. It is assumed that everyone who will be associated with the equipment will be familiar with the contents of the Safety Section.

Explanation of Symbols & Labels

The meaning of symbols and labels which may be used on the equipment or in the product documentation, is given below.

Caution: refer to product information



Caution: risk of electric shock

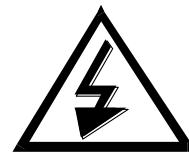

Functional earth terminal

Note: this symbol may also be used for a protective/safety earth terminal if that terminal is part of a terminal block or sub-assembly eg. power supply.

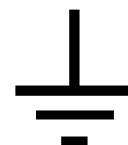

Unpacking

Upon receipt inspect the outer shipping carton or pallet for obvious damage.

Remove the individually packaged relays and inspect the cartons for obvious damage.

To prevent the possible ingress of dirt the carton should not be opened until the relay is to be used.
Refer to the following images for unpacking the relay:



Outer packing carton showing shipping documentation pouch.
Address label on top of carton.



1M122A Sub Rack System

Accessories



M4 terminal screws with captured lock washers

Storage & Handling

If damage has been sustained a claim should immediately be made against the carrier, also inform Relay Monitoring Systems Pty Ltd and the nearest RMS agent

When not required for immediate use, the relay should be returned to its original carton and stored in a clean, dry place.

Relays which have been removed from their cases should not be left in situations where they are exposed to dust or damp. This particularly applies to installations which are being carried out at the same time as constructional work.

If relays are not installed immediately upon receipt they should be stored in a place free from dust and moisture in their original cartons.

Dust which collects on a carton may, on subsequent unpacking, find its way into the relay; in damp conditions the carton and packing may become impregnated with moisture and the de-humidifying agent will lose its efficiency.

Equipment Operating Conditions

The equipment should be operated within the specified electrical and environmental limits.

Protective relays, although generally of robust construction, require careful treatment prior to installation and a wise selection of site. By observing a few simple rules the possibility of premature failure is eliminated and a high degree of performance can be expected.

Care must be taken when unpacking and installing the relays so that none of the parts are damaged or their settings altered and must at all times be handled by skilled persons only.

Relays should be examined for any wedges, clamps, or rubber bands necessary to secure moving parts to prevent damage during transit and these should be removed after installation and before commissioning.

The relay should be mounted on the circuit breaker or panel to allow the operator the best access to the relay functions.

Recommended Mounting

The 1M122A system is supplied mounted in a 19 inch sub rack frame and pre-wired between individual modules. The sub rack frame may be specified for 19 inch rack mounting or alternatively for flush panel mounting on a cubicle or door.

Relevant Auto Cad files & details on other accessories such as 19 inch sub rack frames, semi projection mount kits & stud terminal kits may be down loaded from the website.

19 Inch Rack Mounting

The 19 inch sub rack frame is designed to suit standard 19 inch rack panels.

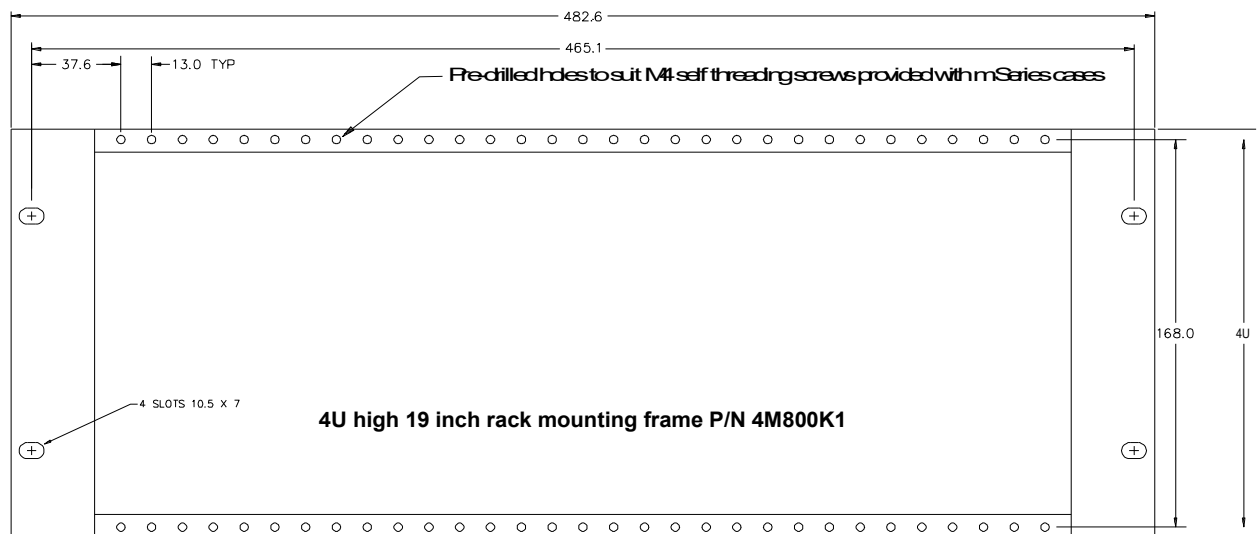

Flush Panel Mounting

The 19 inch sub rack frame may also be flush mounted on a cubicle panel or door.

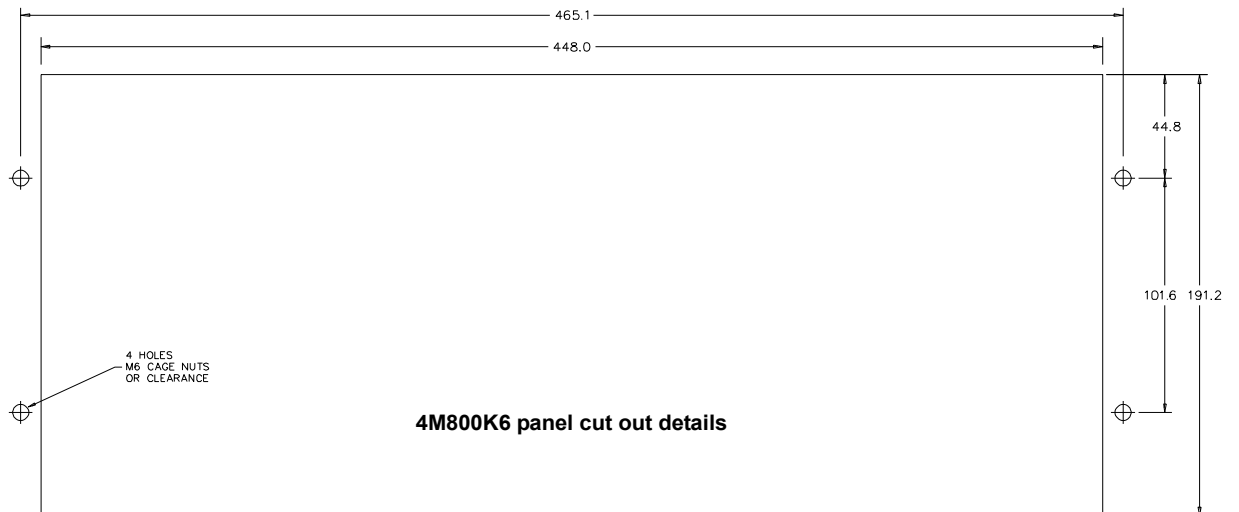
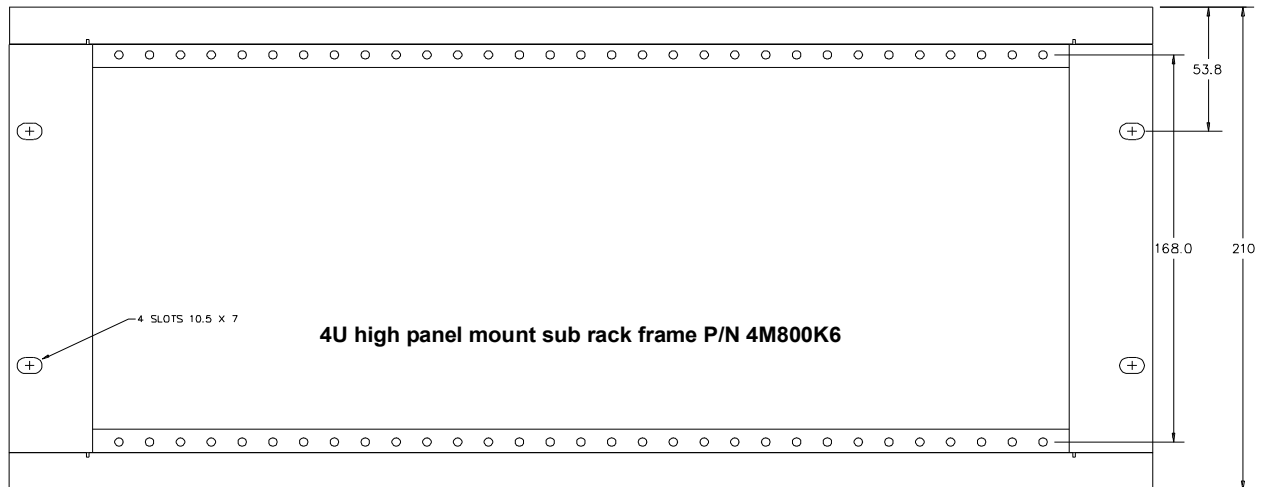

Scheme Wiring

Distributed Scheme

The 1M122A racks may be mounted in a separate cubicle for each transformer in a distributed scheme.

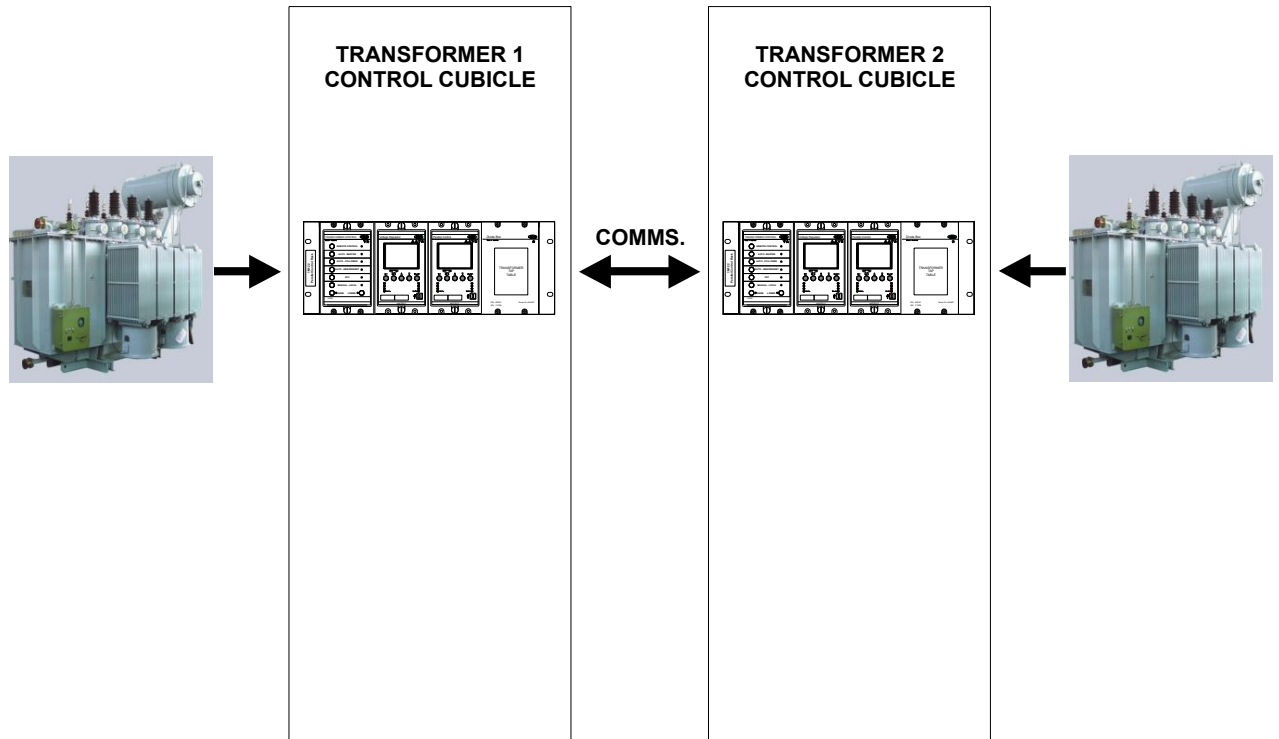

Centralized Scheme

Alternatively, they may all be mounted in the same cubicle for a centralized scheme.

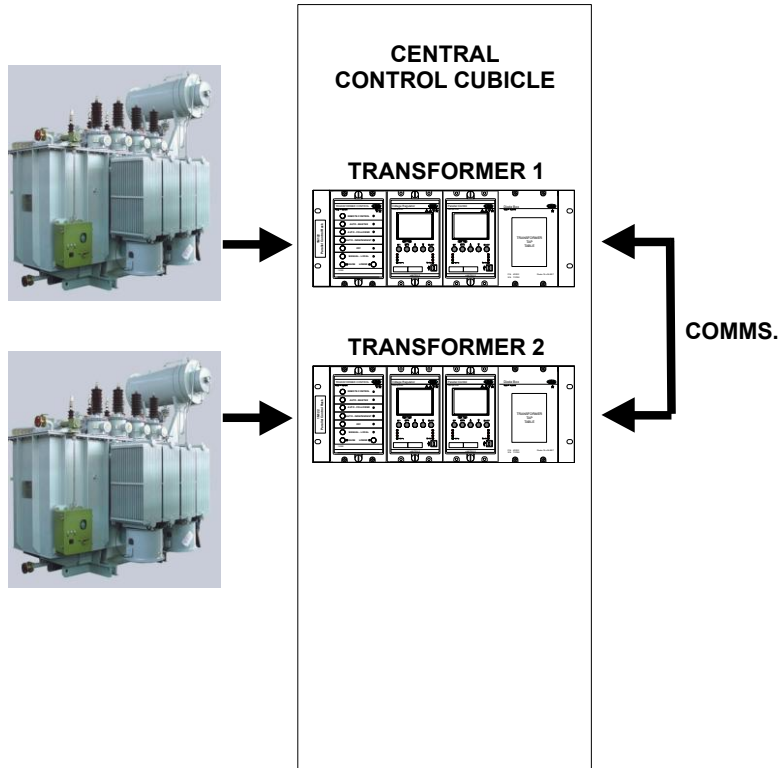

Recommended Cubicle Wiring Scheme

A 1M122A sub rack is required for each transformer control cubicle. It is recommended that wiring from each 1M122A system be connected to rail mounting marshalling terminals as depicted below:

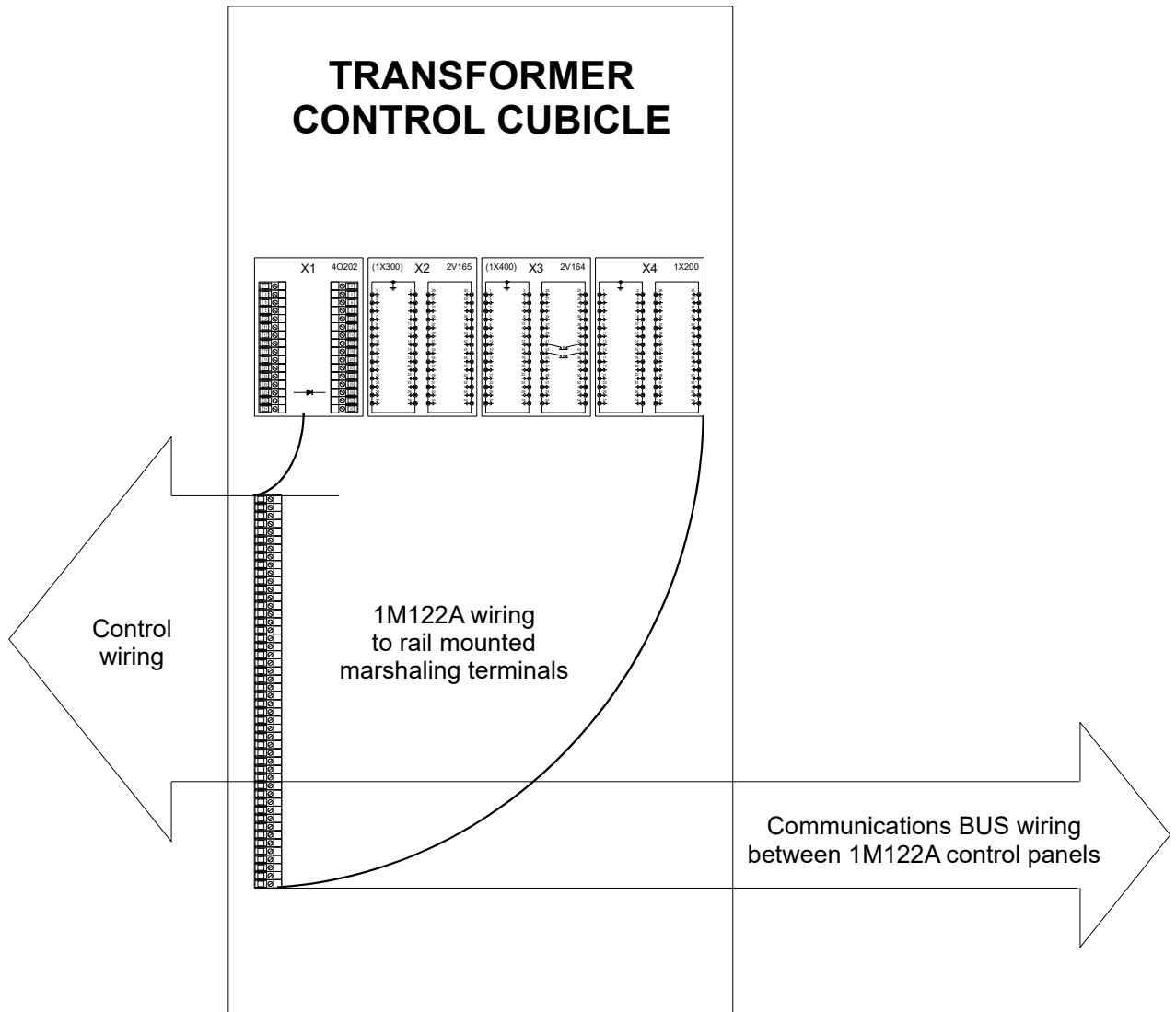

Signalling between each 1M122A is accomplished via a conventional hard wired BUS.

Equipment Connections

Personnel undertaking installation, commissioning or servicing work on this equipment should be aware of the correct working procedures to ensure safety. The product documentation should be consulted before installing, commissioning or servicing the equipment.

Terminals exposed during installation, commissioning and maintenance may present hazardous voltage unless the equipment is electrically isolated.

If there is unlocked access to the rear of the equipment, care should be taken by all personnel to avoid electric shock or energy hazards.

Voltage and current connections should be made using insulated crimp terminations to ensure that terminal block insulation requirements are maintained for safety. To ensure that wires are correctly terminated, the correct crimp terminal and tool for the wire size should be used.

Before energising the equipment it must be earthed using the protective earth terminal, or the appropriate termination of the supply plug in the case of plug connected equipment. Omitting or disconnecting the equipment earth may cause a safety hazard.

The recommended minimum earth wire size is 2.5mm², unless otherwise stated in the technical data section of the product documentation.

Before energising the equipment, the following should be checked:

1. Voltage rating and polarity;
2. CT circuit rating and integrity of connections;
3. Protective fuse rating;
4. Integrity of earth connection (where applicable)

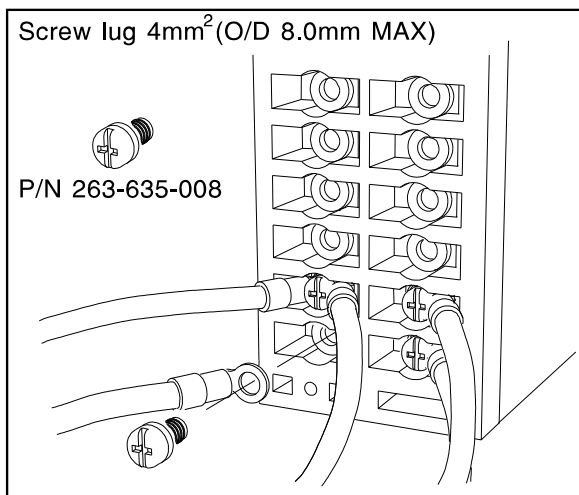

Termination Ring Lugs

Reliable electrical connections to M Series cases is achieved using M4 screws & a right angle ring lug terminal. Termination of wires ranging in size from 0.25mm² up to 2.6mm² is possible using an appropriate ring lug terminal.



Ring Lug Dimensions

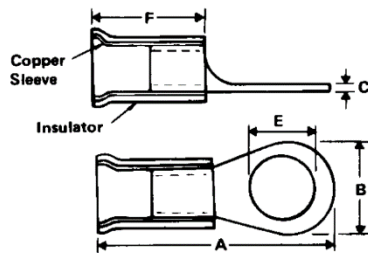

Referring to dimensions “E” and “B” above, the terminal block can accommodate the following lug dimensions:

- “E” greater than 4mm
- “B” less than 8mm

Ring Lugs without 90 Degree Pre-form

Ring lugs are available from various suppliers in a wide range of sizes & configurations. Termination of wires ranging from 0.5mm² up to 6mm² is possible using a ring lug terminal or equivalent.

Common 'flat' lugs do not have the 90 degree pre-bend depicted in figure 9. In order to fit these lugs into the M Series terminal block, an angle must be pre-formed as depicted below:

Multi strand wire

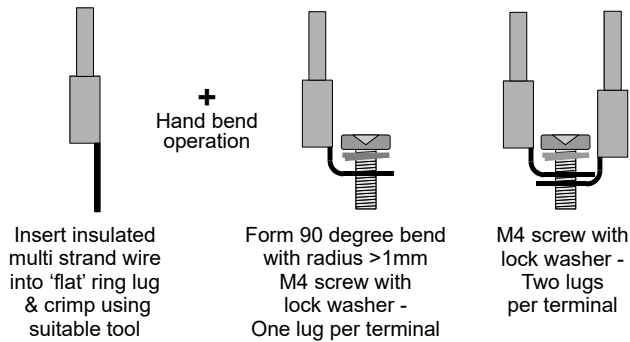

Rear Terminal Arrangement

Each relay in the 1M122 rack is denoted with an X_ designation as per the diagram below.

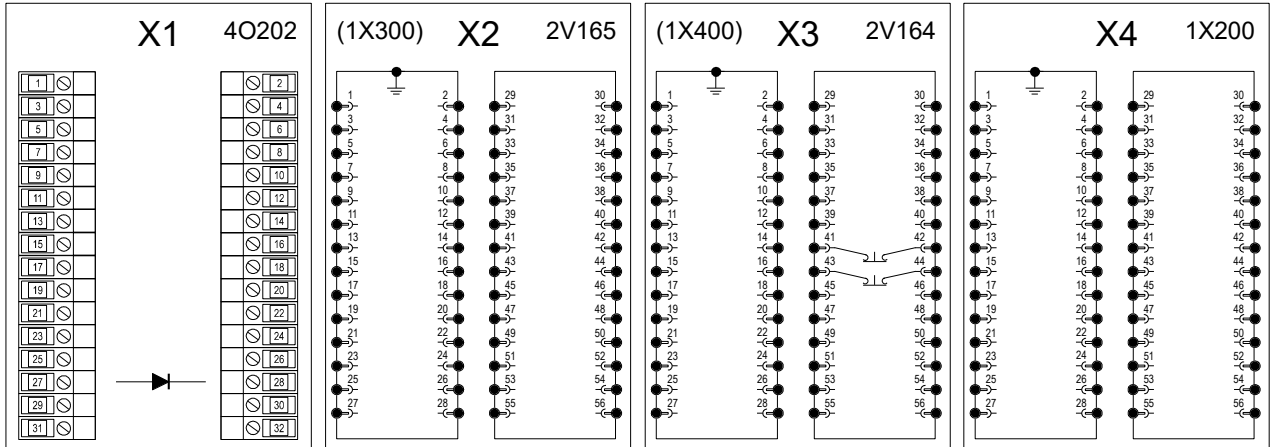

Relay Designation	Relay Type	Function Description
X1	4O202	Diode Box
X2	2V165-S	Parallel Control Unit
X3	2V164-S	Voltage Regulating Relay
X4	1X200	Transformer Control Panel

All racks come delivered with the minimum generic factory pre wiring.

Additional mandatory and application specific wiring needs to be completed by the customer for the correct functioning of the Parallel control scheme.

The following wiring Steps outline the necessary mandated scheme connections and inter scheme connections.



1M122A Front view

Wiring Diagram

4O202 X1 Vx2 input and output notes

For order codes
 1M122A - ##A###
 1M122A - ##B###
 1M122A - ##C###

27	29	31	28	30	32
Vx2 AC/DC+	Vx2 in+	Vx2 in-	Vx2 out+	Vx2 out-	Vx2 Field

Vx2 Field output is the same as the Vx2 input

For order code
 1M122A - ##D###

220V	27	28	30	110V	+
110V	29	30	110V	+	+
0V	31	32	0V	-	-
VAC	IN	VDC	OUT	VDC	DC

Vx2 Field output is 110V DC

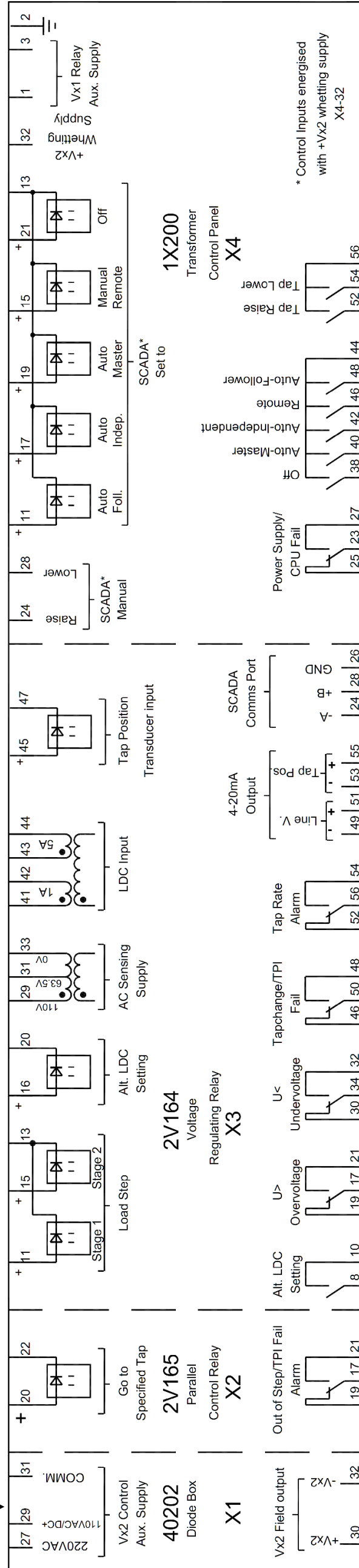

Step by Step Wiring Guide

Step 1 : Transformer Control System Configuration

Each 1M122A sub rack system must be configured to operate with a specific transformer number in the parallel control scheme.

This is achieved by fitting wire links between the 1M122A terminals as depicted in the link tables below :

TRANSFORMER 1 1M122 Rack		
Link	From	To
1	X1-7	X4-36
2	X2-30	X1-15
3	X2-32	X1-17
4	X2-35	X3-45
5	X2-37	X3-47

TRANSFORMER 2 1M122 Rack		
Link	From	To
1	X1-9	X4-36
2	X2-36	X1-15
3	X2-38	X1-17
4	X2-39	X3-45
5	X2-41	X3-47

TRANSFORMER 3 1M122 Rack		
Link	From	To
1	X1-11	X4-36
2	X2-42	X1-15
3	X2-44	X1-17
4	X2-43	X3-45
5	X2-45	X3-47

TRANSFORMER 4 1M122 Rack		
Link	From	To
1	X1-13	X4-36
2	X2-48	X1-15
3	X2-50	X1-17
4	X2-47	X3-45
5	X2-49	X3-47

Step 2 : 1M122A Rack External Connections (Mandatory)

Correct functioning of the 1M122A Parallel control scheme requires each rack to be externally connected to its respective Measurement Circuit, Tap Changer Mechanism, Tap Position Feedback and Auxiliary supplies.

The following outlines the mandatory external connections for each respective Transformer rack.

1M122 Rack Vx1 Aux Supply	
Terminal	Description
X4-1	Active or Pos
X4-3	Common
X4-2	Earth

1M122 Rack Tap Raise and Tap Lower Output to tap changer	
Terminal	Description
X4-52	Raise
X4-54	Lower
X4-56	Common

1M122 Rack Vx2 Control Aux Supply	
Terminal	Description
X1-27	220VAC*
X1-29	110VAC*/+VDC**
X1-31	Common

1M122 Rack Tap Position Transducer Input	
Terminal	Description
X3-45	2V200 Output
X3-47	2V200 Output

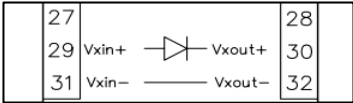
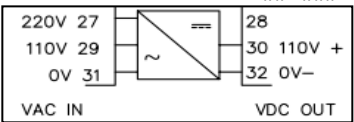
Vx2 input and output notes	
**For order codes 1M122A - ##A### 1M122A - ##B### 1M122A - ##C###	
	
Vx2 Field output is the same as the Vx2 input & terminal X1-27 is not used	
* For order code 1M122A - ##D###	
	
Vx2 Field output is 110V DC	

1M122 Rack Voltage Transformer Input	
Terminal	Description
X3-29	110V (Polarity)
X3-31	63.5V (Polarity)
X3-33	0V (Non Polarity)

Step 3 : 1M122A Rack External Connections (Application Specific)

Application specific controls, alarms and status need to be wired to each of 1M122A Parallel control schemes.

Control inputs are whetted by the +Vx2 supply via voltage free control system contacts.

The following outlines the application specific external connections for each respective Transformer rack :

1M122 Rack Current Transformer Input (Where LDC employed)	
Terminal	Description
X3-41	1A (Polarity)
X3-42	1A (Non Polarity)
X3-43	5A (Polarity)
X3-44	5A (Non Polarity)

1M122 Rack Remote Raise and Lower (Control Inputs)	
Terminal	Description
X4-24	Manual Raise (+)
X4-28	Manual Lower (+)
X4-32	Whetting Supply (+Vx2 only)

1M122 Rack Set To Remote (Control Input)	
Terminal	Description
X4-15	Remote (+)
X4-32	Whetting Supply (+Vx2 only)

1M122 Rack Set To Master (Control Input)	
Terminal	Description
X4-19	Master (+)
X4-32	Whetting Supply (+Vx2 only)

1M122 Rack Set To Follower (Control Input)	
Terminal	Description
X4-11	Follower (+)
X4-32	Whetting Supply (+Vx2 only)

1M122 Rack Set To Independent (Control Input)	
Terminal	Description
X4-17	Independent (+)
X4-32	Whetting Supply (+Vx2 only)

1M122 Rack Power Supply/CPU Fail (Alarm)	
Terminal	Description
X4-25	Normally closed
X4-27	Normally open
X4-23	Common

1M122 Rack Set To Off (Control)	
Terminal	Description
X4-21	Off (+)
X4-32	Whetting Supply (+Vx2 only)

1M122 Rack Over Voltage (Alarm)	
Terminal	Description
X3-19	Normally closed
X3-21	Normally open
X3-17	Common

1M122 Rack Tap Position Analogue (Output)	
Terminal	Description
X3-53	- 4-20mA
X3-55	+ 4-20mA

1M122 Rack Under Voltage Block (Alarm)	
Terminal	Description
X3-30	Normally closed
X3-32	Normally open
X3-34	Common

1M122 Rack Measured Voltage Analogue (Output)	
Terminal	Description
X3-49	- 4-20mA
X3-51	+ 4-20mA

1M122 Rack Tap Change Fail/TPI Fail (Alarm)	
Terminal	Description
X3-46	Normally closed
X3-48	Normally open
X3-50	Common

1M122 Rack Tap Rate (Alarm)	
Terminal	Description
X3-52	Normally closed
X3-54	Normally open
X3-56	Common

1M122 Rack Out of Step/TPI Fail (Alarm)	
Terminal	Description
X2-19	Normally closed
X2-21	Normally open
X2-17	Common

1M122 Rack Alternate LDC Setting (Status)	
Terminal	Description
X3-8	Normally open
X3-10	Normally open

1M122 Rack Operation Mode (Status)	
Terminal	Description
X4-38	Off (NO)
X4-40	Master (NO)
X4-42	Independent (NO)
X4-44	Common
X4-46	Remote (NO)
X4-48	Auto - Follower (NO)

1M122 Rack	
Field Whetting Supply Vx2 for Control inputs as required below	
Terminal	Description
X1-30	+Vx2
X1-32	-Vx2

Vx2 input and output notes

**For order codes
1M122A - ##A###
1M122A - ##B###
1M122A - ##C###

27	Vxin+		Vxout+	28
29	Vxin-	—	Vxout-	30
31	Vxin-	—	Vxout-	32

Vx2 Field output is the same as the Vx2 input

* For order code 1M122A - ##D###

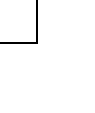
220V 27		28
110V 29		30 110V +
0V 31		32 0V-
VAC IN		VDC OUT

Vx2 Field output is 110V DC

1M122 Rack	
Load Step Stage 1 (Control Input) (Use Vx2 field whetting supply)	
Terminal	Description
X3-11	Load Step Stage 1 (+)
X3-13	Load Step Stage 1 (-)

1M122 Rack	
Load Step Stage 2 (Control Input) (Use Vx2 field whetting supply)	
Terminal	Description
X3-15	Load Step Stage 2 (+)
X3-13	Load Step Stage 2 (-)

1M122 Rack	
Go to Specified Tap (Control Input) (Use Vx2 field whetting supply)	
Terminal	Description
X2-20	Go to Specified Tap (+)
X2-22	Go to Specified Tap (-)

1M122 Rack	
Alternate LDC Setting Group (Control Input) (Use Vx2 field whetting supply)	
Terminal	Description
X3-16	Alternate LDC Setting (+)
X3-20	Alternate LDC Setting (-)

Step 4 : Bus Wiring (Inter scheme Bus Wiring)

The following schedule nominates the necessary Inter scheme Bus Wiring for the correct functioning of the 1M122 parallel control scheme :

Bus wire connections across all transformers		
Bus wires	1M122 Connections	Description
B1	X1-30	Vx2 (+)
B2	X1-32	Vx2 (-)
B3	X4-10	Follower Interlock
B4	X1-7	T1 On Line Signal
B5	X2-30	T1 Raise Volts Command
B6	X2-32	T1 Lower Volts Command
B7	X2-35	T1 Tap Position 2V200 Output
B8	X2-37	T1 Tap Position 2V200 Output
B9	X1-9	T2 On Line Signal
B10	X2-36	T2 Raise Volts Command
B11	X2-38	T2 Lower Volts Command
B12	X2-39	T2 Tap Position 2V200 Output
B13	X2-41	T2 Tap Position 2V200 Output
B14	X1-11	T3 On Line Signal
B15	X2-42	T3 Raise Volts Command
B16	X2-44	T3 Lower Volts Command
B17	X2-43	T3 Tap Position 2V200 Output
B18	X2-45	T3 Tap Position 2V200 Output
B19	X1-13	T4 On Line Signal
B20	X2-48	T4 Raise Volts Command
B21	X2-50	T4 Lower Volts Command
B22	X2-47	T4 Tap Position 2V200 Output
B23	X2-49	T4 Tap Position 2V200 Output

2V200 Tap Position Transducer Connections

The 2V200 is housed in a surface or DIN rail mount case comprising a terminal base and separate plug in electronic module as depicted below.

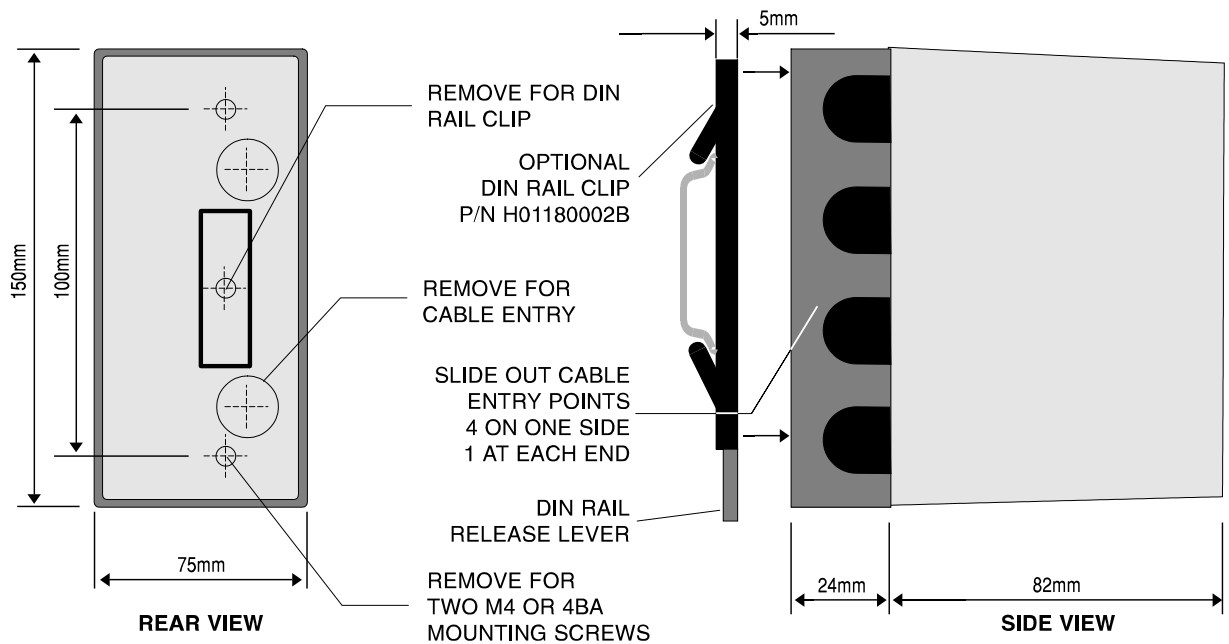
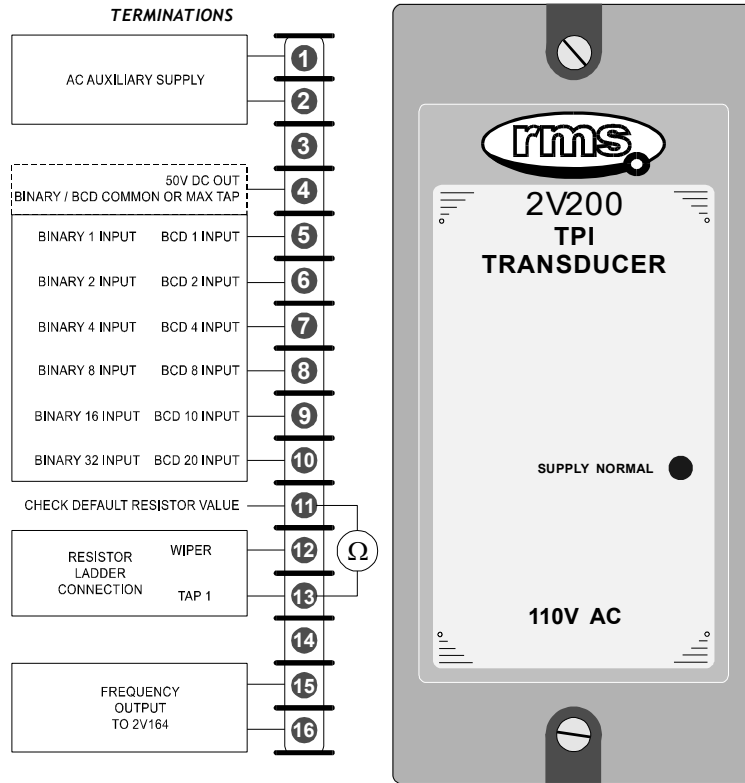

2V200 Tap Position Transducer Wiring Interface

The 2V200 is specifically designed for operation with the RMS type 2V164 Voltage Regulating Relay and 2V165 Parallel Control Relay employed in the 1M122A parallel control scheme.

The 2V200 is designed to interface with tap changers using either binary / BCD coded signals or a traditional voltage divider circuit. The 2V200 generates a 50V DC output to connect to the auxiliary contacts on the tap changer.

For parallel control applications the BCD or binary interface between the tap changer and 2V200 is recommended.

For long runs between the 2V200 and 1M122A, shielded cable is recommended.

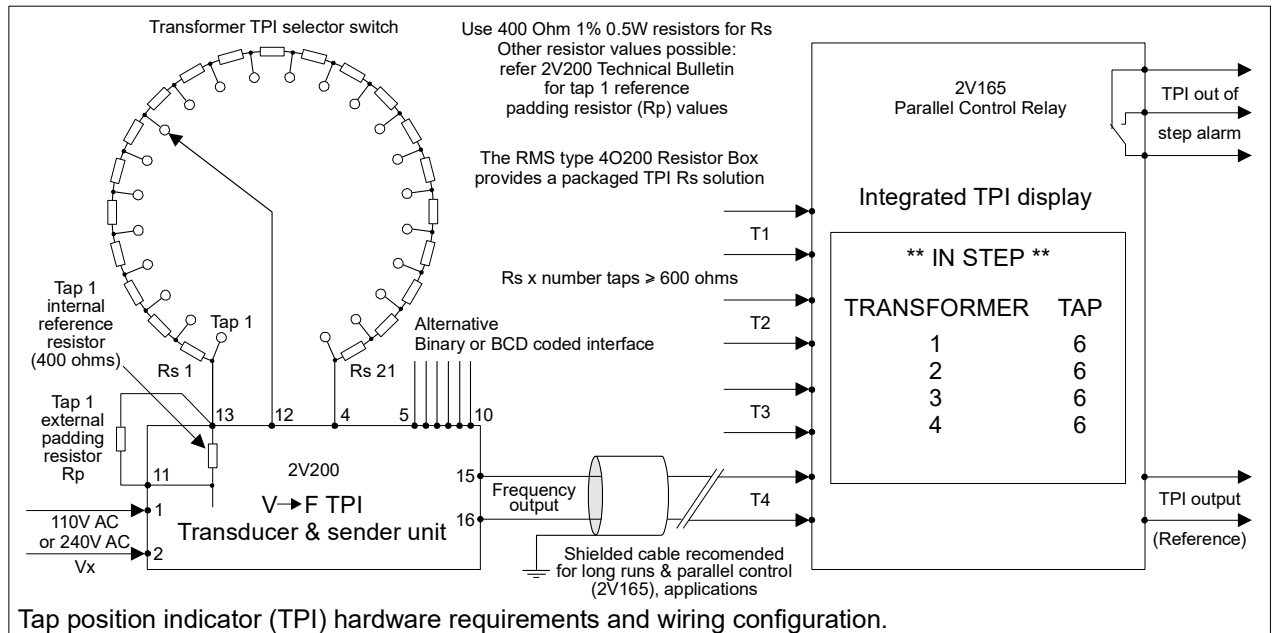

Relay Setting

The 2V164 Voltage Regulating Relay and the 2V165 Parallel Control Relay must have appropriate settings loaded to ensure correct operation of the scheme and to provide the desired voltage regulation.

Relays are shipped loaded with basic settings however these will need to be updated to suit specific requirements.

Relay setting can be carried out at the front panel or using the USB configuration port with a PC running the uMATRIXwin setting software. Refer to the μ MATRIX Users Guide for detailed instructions on the operation of the user interface.

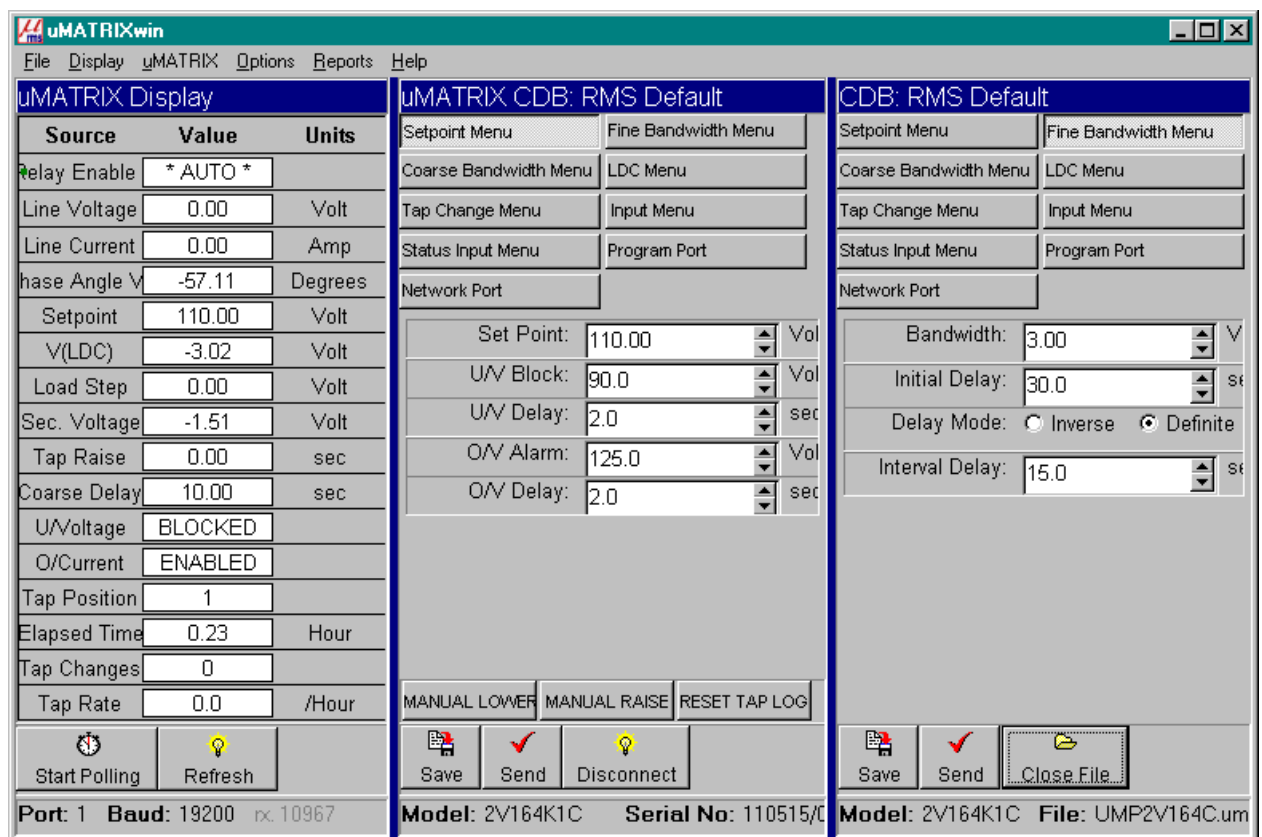

The screenshot displays the uMATRIXwin software interface, which is divided into three main sections: uMATRIX Display, uMATRIX CDB: RMS Default, and CDB: RMS Default.

uMATRIX Display: This section contains a table of relay parameters and their current values.

Source	Value	Units
Relay Enable	* AUTO *	
Line Voltage	0.00	Volt
Line Current	0.00	Amp
Phase Angle V	-57.11	Degrees
Setpoint	110.00	Volt
V(LDC)	-3.02	Volt
Load Step	0.00	Volt
Sec. Voltage	-1.51	Volt
Tap Raise	0.00	sec
Coarse Delay	10.00	sec
UVoltage	BLOCKED	
O/Current	ENABLED	
Tap Position	1	
Elapsed Time	0.23	Hour
Tap Changes	0	
Tap Rate	0.0	/Hour

Below the table are buttons for 'Start Polling' and 'Refresh'. At the bottom, it shows 'Port: 1 Baud: 19200 rx: 10967'.

uMATRIX CDB: RMS Default: This section contains various menu options and numerical settings.

- Menu options: Setpoint Menu, Fine Bandwidth Menu, Coarse Bandwidth Menu, LDC Menu, Tap Change Menu, Input Menu, Status Input Menu, Program Port, Network Port.
- Set Point: 110.00 Vol
- UV Block: 90.0 Vol
- UV Delay: 2.0 sec
- O/V Alarm: 125.0 Vol
- O/V Delay: 2.0 sec

At the bottom are buttons for 'MANUAL LOWER', 'MANUAL RAISE', and 'RESET TAP LOG', along with 'Save', 'Send', and 'Disconnect'.

CDB: RMS Default: This section contains additional numerical settings.

- Bandwidth: 3.00 V
- Initial Delay: 30.0 sec
- Delay Mode: Inverse Definite
- Interval Delay: 15.0 sec

At the bottom are buttons for 'Save', 'Send', and 'Close File'. The status bar shows 'Model: 2V164K1C Serial No: 110515/0' and 'Model: 2V164K1C File: UMP2V164C.um'.

Critical Settings

The 2V164 Voltage Regulating Relay is shipped with settings that should provide basic voltage regulation functionality based on a nominal 110V AC VT input.

There are a number of other settings however, that must be set up specifically to match the tap changer to ensure correct parallel control functionality.

Critical 2V164 Settings (umx2V164I_XXXX)

- ❑ Offlines settings are undertaken using the UMP2V164I_XXXX.ump setting template
- ❑ Set the 2V200 transducer interface to:
 - ANALOGUE if using a resistive divider interface to the tap changer

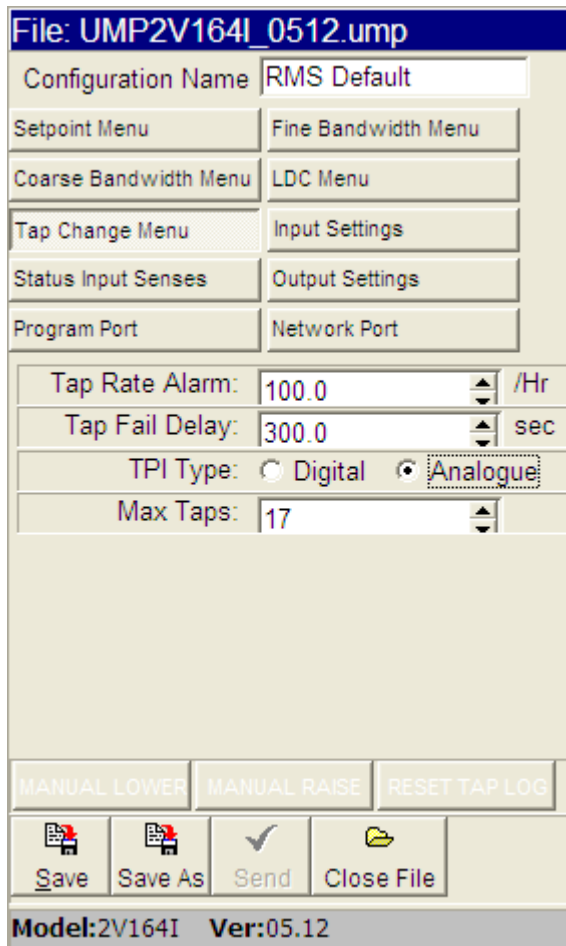

File: UMP2V164I_0512.ump

Configuration Name	RMS Default
Setpoint Menu	Fine Bandwidth Menu
Coarse Bandwidth Menu	LDC Menu
Tap Change Menu	Input Settings
Status Input Senses	Output Settings
Program Port	Network Port
Tap Rate Alarm:	100.0 /Hr
Tap Fail Delay:	300.0 sec
TPI Type:	<input type="radio"/> Digital <input checked="" type="radio"/> Analogue
Max Taps:	17

MANUAL LOWER MANUAL RAISE RESET TAP LOG

Save Save As Send Close File

Model:2V164I Ver:05.12

Set TPI Type to Analogue

- DIGITAL if using a BCD or binary interface to the tap changer

File: UMP2V164I_0512.ump	
Configuration Name	RMS Default
Setpoint Menu	Fine Bandwidth Menu
Coarse Bandwidth Menu	LDC Menu
Tap Change Menu	Input Settings
Status Input Senses	Output Settings
Program Port	Network Port
Tap Rate Alarm:	100.0 /Hr
Tap Fail Delay:	300.0 sec
TPI Type:	<input checked="" type="radio"/> Digital <input type="radio"/> Analogue
Max Taps:	30
MANUAL LOWER MANUAL RAISE RESET TAP LOG	
<input type="button" value="Save"/> <input type="button" value="Save As"/> <input type="button" value="Send"/> <input type="button" value="Close File"/>	
Model:2V164I Ver:05.12	

Set TPI Type to Digital

- ❑ For ANALOGUE set the MAXIMUM TAP position of the tap changer

File: UMP2V164I_0512.ump

Configuration Name	RMS Default
Setpoint Menu	Fine Bandwidth Menu
Coarse Bandwidth Menu	LDC Menu
Tap Change Menu	Input Settings
Status Input Senses	Output Settings
Program Port	Network Port

Tap Rate Alarm:	100.0	/Hr
Tap Fail Delay:	300.0	sec
TPI Type:	<input type="radio"/> Digital	<input checked="" type="radio"/> Analogue
Max Taps:	17	

MANUAL LOWER MANUAL RAISE RESET TAP LOG

Save Save As Send Close File

Model:2V164I Ver:05.12

Max Taps to the actual Maximum Tap number (in this example Tap 17)

- ❑ Do not change the Status Input menu defaults:

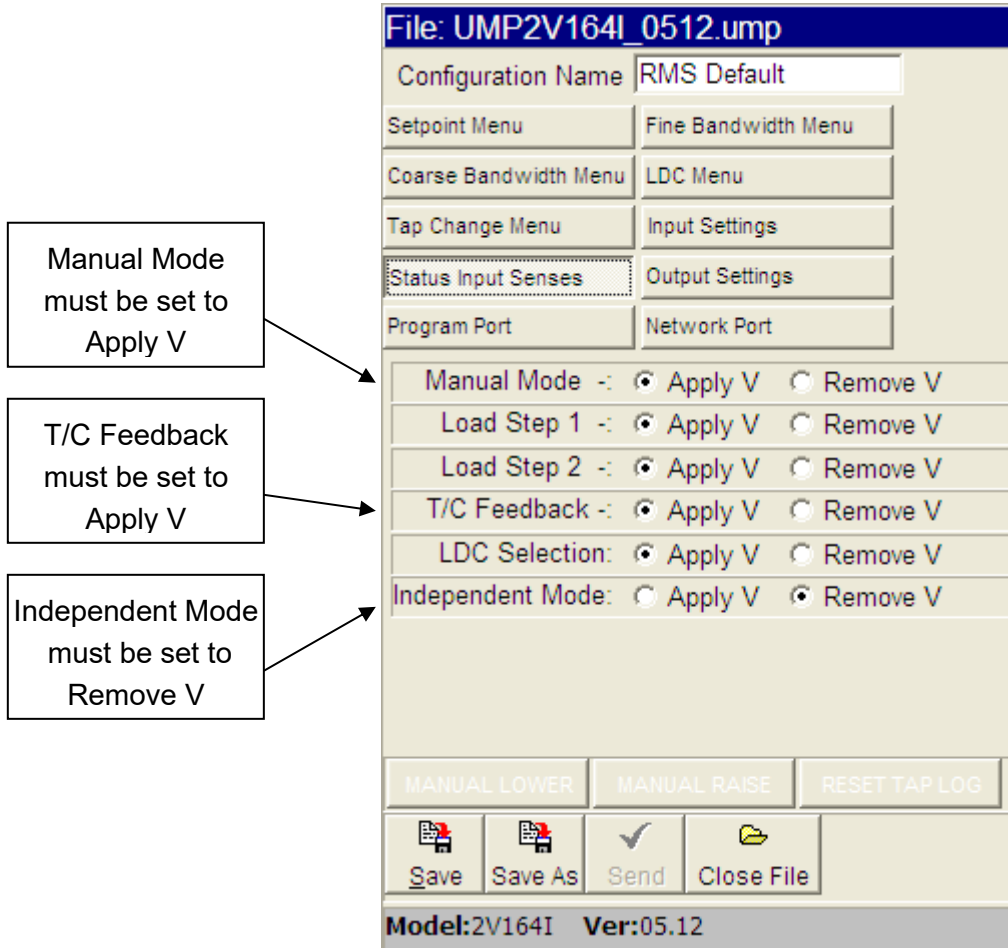

File: UMP2V164I_0512.ump

Configuration Name	RMS Default
Setpoint Menu	Fine Bandwidth Menu
Coarse Bandwidth Menu	LDC Menu
Tap Change Menu	Input Settings
Status Input Senses	Output Settings
Program Port	Network Port

Manual Mode	-:	<input checked="" type="radio"/> Apply V	<input type="radio"/> Remove V
Load Step 1	-:	<input checked="" type="radio"/> Apply V	<input type="radio"/> Remove V
Load Step 2	-:	<input checked="" type="radio"/> Apply V	<input type="radio"/> Remove V
T/C Feedback	-:	<input checked="" type="radio"/> Apply V	<input type="radio"/> Remove V
LDC Selection	:	<input checked="" type="radio"/> Apply V	<input type="radio"/> Remove V
Independent Mode	:	<input type="radio"/> Apply V	<input checked="" type="radio"/> Remove V

MANUAL LOWER MANUAL RAISE RESET TAP LOG

Save Save As Send Close File

Model:2V164I Ver:05.12

Manual Mode must be set to Apply V

T/C Feedback must be set to Apply V

Independent Mode must be set to Remove V

Critical 2V165 Settings (umx2V165C_XXXX)

- ❑ Offlines settings are undertaken using the UMP2V165C_XXXX.ump setting template
- ❑ Set the 2V200 transducer interface to:
 - ANALOGUE if using a resistive divider interface to the tap changer

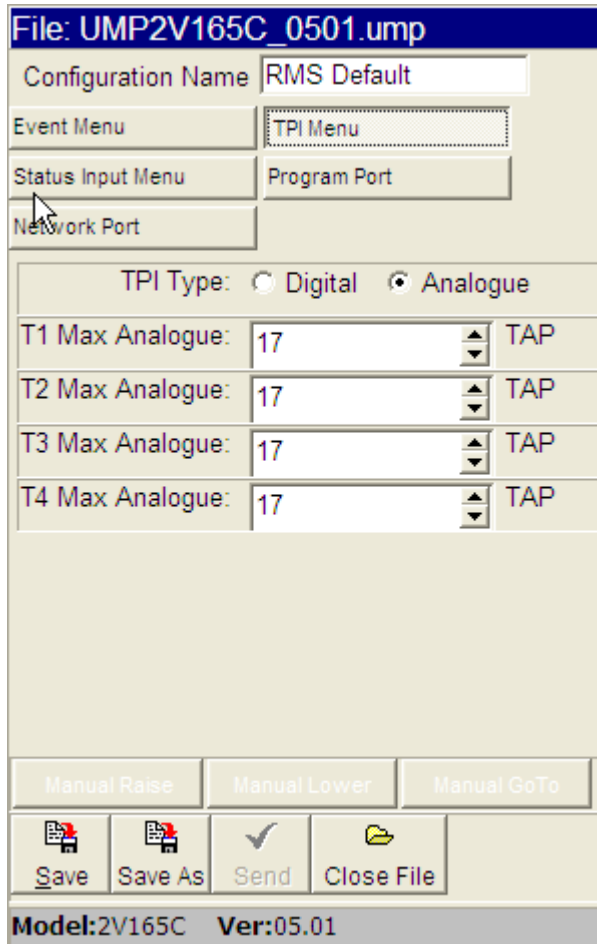

File: UMP2V165C_0501.ump

Configuration Name: RMS Default

Event Menu: TPI Menu

Status Input Menu: Program Port

Network Port:

TPI Type: Digital Analogue

T1 Max Analogue: 17 TAP

T2 Max Analogue: 17 TAP

T3 Max Analogue: 17 TAP

T4 Max Analogue: 17 TAP

Manual Raise Manual Lower Manual GoTo

Save Save As Send Close File

Model:2V165C Ver:05.01

Set TPI Type to Analogue

- DIGITAL if using a BCD or binary interface to the tap changer

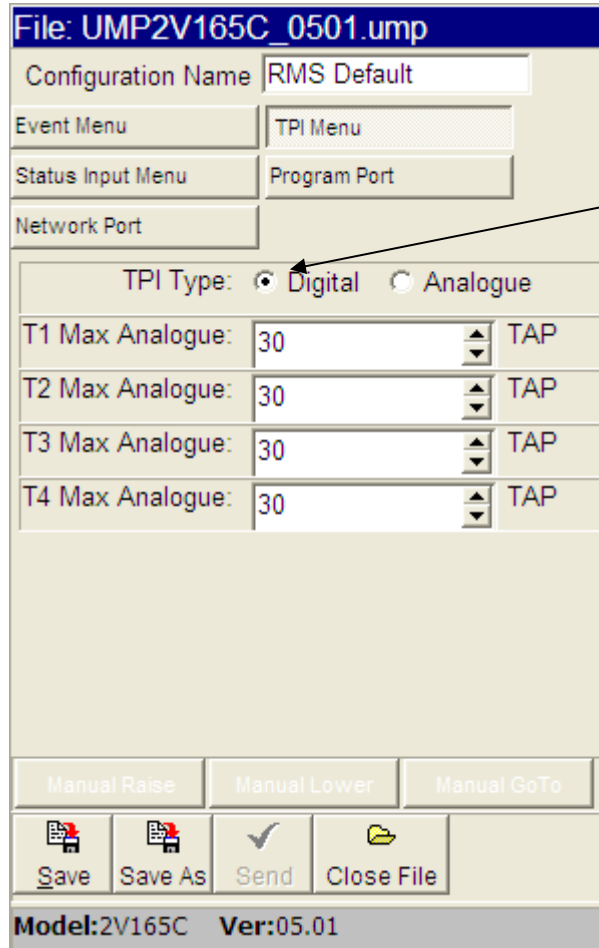

File: UMP2V165C_0501.ump

Configuration Name: RMS Default

Event Menu: TPI Menu

Status Input Menu: Program Port

Network Port:

TPI Type: Digital Analogue

T1 Max Analogue: 30 TAP

T2 Max Analogue: 30 TAP

T3 Max Analogue: 30 TAP

T4 Max Analogue: 30 TAP

Manual Raise Manual Lower Manual GoTo

Save Save As Send Close File

Model: 2V165C Ver: 05.01

Set TPI Type to Digital

- ❑ For ANALOGUE set the MAXIMUM TAP position of the tap changer for each transformer

File: UMP2V165C_0501.ump

Configuration Name: RMS Default

Event Menu: TPI Menu

Status Input Menu: Program Port

Network Port:

TPI Type: Digital Analogue

T1 Max Analogue:	17	TAP
T2 Max Analogue:	17	TAP
T3 Max Analogue:	17	TAP
T4 Max Analogue:	17	TAP





Manual Raise Manual Lower Manual GoTo

Save Save As Send Close File

Model:2V165C Ver:05.01

Max Taps to the actual Maximum Tap number (in this example all transformers have the same max Tap of 17)

- ❑ Leave all Status Input menu defaults (Apply V)

File: UMP2V165C_0501.ump		
Configuration Name	RMS Default	
Event Menu	TPI Menu	
Status Input Menu	Program Port	
Network Port		
T1 On Line -:	<input checked="" type="radio"/> Apply V	<input type="radio"/> Remove V
T2 On Line -:	<input checked="" type="radio"/> Apply V	<input type="radio"/> Remove V
T3 On Line -:	<input checked="" type="radio"/> Apply V	<input type="radio"/> Remove V
T4 On Line -:	<input checked="" type="radio"/> Apply V	<input type="radio"/> Remove V
Tap Raise -:	<input checked="" type="radio"/> Apply V	<input type="radio"/> Remove V
Tap Lower -:	<input checked="" type="radio"/> Apply V	<input type="radio"/> Remove V
Goto Tap -:	<input checked="" type="radio"/> Apply V	<input type="radio"/> Remove V
Manual Raise	Manual Lower	Manual GoTo
 Save	 Save As	 Send
		 Close File
Model:2V165C Ver:05.01		

Application Note – Using Mixed Tap Position Indicator Transducer Types

The 1M122 Parallel control scheme may be utilised with Tap changers with mixed Analogue or Digital Tap Position Indicator Transducer Types.

For correct operation the 2V164 and 2V165 relays for each Tap Changer must be set in the following manner:

- 2V164 Settings for Tap Changers in Scheme with Analogue TPI

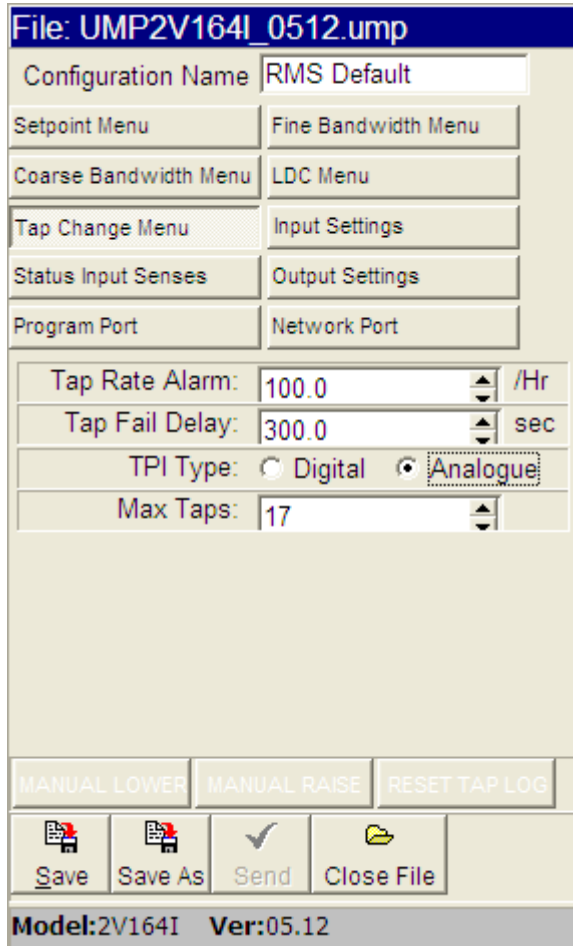

File: UMP2V164I_0512.ump

Configuration Name	RMS Default
Setpoint Menu	Fine Bandwidth Menu
Coarse Bandwidth Menu	LDC Menu
Tap Change Menu	Input Settings
Status Input Senses	Output Settings
Program Port	Network Port

Tap Rate Alarm: 100.0 /Hr

Tap Fail Delay: 300.0 sec

TPI Type: Digital Analogue

Max Taps: 17

MANUAL LOWER MANUAL RAISE RESET TAP LOG

Save Save As Send Close File

Model:2V164I Ver:05.12

Set TPI Type to Analogue

Max Taps to the actual Maximum Tap number (in this example Tap 17)

- 2V164 Settings for Tap Changers in Scheme with Digital TPI

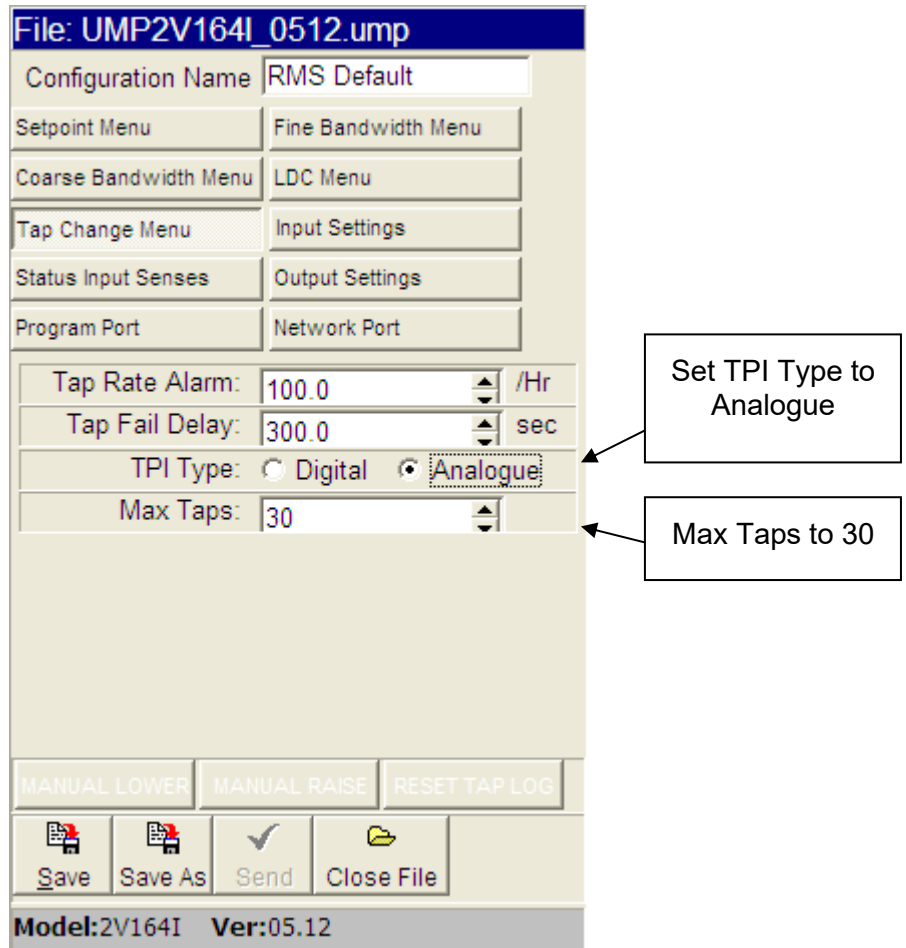

File: UMP2V164I_0512.ump

Configuration Name	RMS Default
Setpoint Menu	Fine Bandwidth Menu
Coarse Bandwidth Menu	LDC Menu
Tap Change Menu	Input Settings
Status Input Senses	Output Settings
Program Port	Network Port

Tap Rate Alarm: 100.0 /Hr

Tap Fail Delay: 300.0 sec

TPI Type: Digital Analogue

Max Taps: 30

MANUAL LOWER MANUAL RAISE RESET TAP LOG

Save Save As Send Close File

Model:2V164I Ver:05.12

Set TPI Type to Analogue

Max Taps to 30

- 2V165 Settings for mixed Tap Changers in Scheme (in this example T1, T3 & T4 have Tap changers with 17 positions and Analogue TPIs whilst T2 has a Digital TPI)

File: UMP2V165C_0501.ump

Configuration Name: RMS Default

Event Menu: TPI Menu

Status Input Menu: Program Port

Network Port:

TPI Type: Digital Analogue

T1 Max Analogue:	17	TAP
T2 Max Analogue:	30	TAP
T3 Max Analogue:	17	TAP
T4 Max Analogue:	17	TAP

Manual Raise Manual Lower Manual GoTo

Save Save As Send Close File

Model:2V165C Ver:05.01

Set TPI Type to Analogue

Max Taps for T2 set to 30
(All other Transformers set to 17)

Commissioning

Commissioning Preliminaries

Carefully examine the module and case to ensure that no damage has occurred during transit. Check that the relay serial number on the module, case and cover are identical, and that the model number and rating information are correct.

Note that shorting switches shown on the relay diagram are fitted internally across the relevant case terminals and close when the module is withdrawn. It is essential that such switches are fitted across all CT circuits.

Earthing

Ensure that the case earthing connection above the rear terminal block is used to connect the relay to a local earth bar.

Insulation

The relay, and its associated wiring, may be insulation tested between:

- all electrically isolated circuits
- all circuits and earth

An electronic or brushless insulation tester should be used, having a dc voltage not exceeding 1000V. Accessible terminals of the same circuit should first be strapped together. Deliberate circuit earthing links, removed for the tests, subsequently must be replaced.

Commissioning Tests

If the relay is wired through a test block it is recommended that all secondary injection tests should be carried out using this block.

Ensure that the main system current transformers are shorted before isolating the relay from the current transformers in preparation for secondary injection tests.

DANGER

DO NOT OPEN CIRCUIT THE SECONDARY CIRCUIT OF A CURRENT TRANSFORMER SINCE THE HIGH VOLTAGE PRODUCED MAY BE LETHAL AND COULD DAMAGE INSULATION.

It is assumed that the initial preliminary checks have been carried out.

Relay CT shorting switches

With the relay removed from its case, check electrically that the CT shorting switch is closed.

Primary injection testings

It is essential that primary injection testing is carried out to prove the correct polarity of current transformers.

Before commencing any primary injection testing it is essential to ensure that the circuit is dead, isolated from the remainder of the system and that only those earth connections associated with the primary test equipment are in position.

Pre Site Commissioning Scheme Verification Checklist

The following tests are to be undertaken following the completion of all 1M122 link wiring, inter scheme bus wiring and all Tap Changer interfaces.

Item	Description	Complete
1	Apply Vx1 Auxiliary and Vx2 Control Auxiliary supplies	
2	Check all relays are powered up and healthy	
3	Confirm 2V164 and 2V165 relay settings are set as per Critical Settings section in user manual	
4	On each 1M122 rack verify Operation of the OFF Mode <ul style="list-style-type: none"> • Confirm 'OFF' repeat output contact closes • Confirm that Local or Remote manual Tap Raise or Lower commands are inhibited 	
5	On each 1M122 rack verify Operation of the OFF Mode <ul style="list-style-type: none"> • Undertake secondary voltage injection to take the voltage out of band and confirm Tap Raise or Lower commands are inhibited 	
6	On each 1M122 rack switch to Manual Mode and Raise Taps <ul style="list-style-type: none"> • Confirm TPI indication on both the 2V164 and 2V165 is correct and corresponds to the physical tap position of the tap changer • Step through each tap up to maximum Tap and confirm TPI indication is consistent with the physical tap position of the tap changer 	
7	On each 1M122 rack switch to Manual Mode and Lower Taps <ul style="list-style-type: none"> • Confirm TPI indication on both the 2V164 and 2V165 is correct and corresponds to the physical tap position of the tap changer • Step through each tap through to minimum Tap and confirm TPI indication is consistent with the physical tap position of the tap changer 	
8	Manually place all transformers on to the same tap position	
9	Switch all the 1M122 racks to the OFF Mode	

Item	Description	Complete
10	<p>Switch one of the 1M122 racks to Auto-Master Mode</p> <ul style="list-style-type: none"> • Confirm that 2V165 indicates correct transformer in group and no out of step conditions, confirm 2V164 is in Auto • Confirm 'Master' repeat output contact closes • Successively place each of the remaining racks into Auto-Follower Mode and confirm Auto-Master 2V165 indicates correct transformer in group and no out of step conditions, respective Auto-Follower 2V164 relays should be indicating Manual • Confirm 'Follower' repeat output contact closes 	
11	<p>Switch one of the Auto-Follower 1M122 racks to Auto-Master Mode</p> <ul style="list-style-type: none"> • Confirm correct functioning of Master Follower interlock, previous Auto-Master should have reverted to Auto-Follower Mode • Confirm correct operation of repeat output contacts • Confirm the new Auto-Master 2V165 indicates correct transformers in group and no out of step conditions, confirm 2V164 is in Auto • For each 1M122 rack invoked as the Auto-Master repeat above series of tests and confirm each 1M122 rack can be invoked as the Auto-Master and respective 2V165 indicates correct transformers in group, correct out of step status and confirm 2V164 is in Auto 	
12	<p>With one of the 1M122 racks set to Auto-Master Mode and the remainder of the racks in Auto-Follower Mode</p> <ul style="list-style-type: none"> • Isolate the Tap Raise and Tap Lower outputs to the tap changer mechanism on one of the transformers • Independent of the 1M122 scheme place the transformer on a different tap to the others in the group • Confirm that an Out of Step Alarm is annunciated, and the correct transformer indicated • Confirm associated Out of Step Alarm output contact closes • Place all racks to the off mode and restore the Tap Raise and Tap Lower outputs • Place one of the 1M122 racks into Auto-Master Mode and the remainder of the racks in Auto-Follower Mode and confirm that the scheme adjusts taps to restore in step conditions, confirm that the Out of Step Alarm is extinguished • Confirm associated Out of Step Alarm output contact drops out • Repeat above for each transformer 	

Item	Description	Complete
13	<p>With one of the 1M122 racks set to Auto-Master Mode and the remainder of the racks in Auto-Follower Mode</p> <ul style="list-style-type: none"> • Disable the TPI for one of the transformers • Confirm that the 'TPI Fail' message is annunciated on the Master 2V165 and the tap position of the affected transformer displays 'TPI OFFLINE' • Confirm operation of the TPI Fail output contact on the 2V165 • Confirm that the 'TPI Fail' message is annunciated on the 2V164 of the affected transformer and the tap position displays 'TPI OFFLINE' • Confirm operation of the TPI Fail output contact on the 2V164 • Restore the TPI • Confirm that the 'TPI Fail' and 'TPI OFFLINE' messages are cleared • Confirm associated TPI Fail output contacts drop out • Repeat above for each transformer in the Master/Follower group 	
14	<p>With one of the 1M122 racks set to Auto-Master Mode and the remainder of the racks in Auto-Follower Mode</p> <ul style="list-style-type: none"> • Undertake secondary voltage injection to take the voltage out of band and confirm Tap Raise and Lower commands are issued to all transformers in the group • Confirm TPI indications are consistent with the physical tap positions of the tap changers • Successively set each 1M122 rack to Auto-Master Mode and repeat above test 	
15	<p>Place one of the 1M122 racks into Auto-Independent Mode</p> <ul style="list-style-type: none"> • Confirm 'INDEPENDENT' repeat output contact closes • Undertake secondary voltage injection into the independent scheme to take the voltage out of band and confirm Tap Raise and Lower commands are issued only to the independent transformer • Undertake secondary voltage injection into the Master-Follower group of transformers to take the voltage out of band and confirm Tap Raise and Lower commands are issued only to the transformers in the same group, and not issued to the independent transformer • Confirm TPI indications are consistent with the physical tap positions of the tap changers • Repeat above for different combinations of grouped and independent transformers 	

Item	Description	Complete
16	Place all the 1M122 racks into Auto-Independent Mode <ul style="list-style-type: none"> • Confirm 'INDEPENDENT' repeat output contact closure on each rack • Undertake secondary voltage injection into each of the independent schemes to take the voltage out of band and confirm Tap Raise and Lower commands are issued only to the respective independent transformer • Confirm TPI indication is consistent with the physical tap positions of the tap changer 	
17	Whilst all the 1M122 racks are in one of the Auto Modes <ul style="list-style-type: none"> • Successively place each 1M122 rack in the Remote Mode • Confirm 'REMOTE' repeat output contact closure on each rack • Undertake secondary voltage injection into each of the Auto groups to take the voltage out of band and confirm Auto Tap Raise and Lower commands are inhibited 	
18	Via secondary voltage injection into each of the 1M122 racks confirm correct voltage is displayed according to injected voltage	
19	Supplementary Checks (Where function is implemented) : With all the 1M122 racks in the REMOTE mode <ul style="list-style-type: none"> • Initiate a REMOTE Manual Raise for each rack • Confirm a Raise command is issued to the correct Tap changer • Initiate a REMOTE Manual Lower for each rack • Confirm a Lower command is issued to the correct Tap changer 	
20	Supplementary Checks (Where function is implemented) : Over voltage alarm <ul style="list-style-type: none"> • For each rack undertake secondary voltage injection beyond the Over voltage alarm setpoint • Confirm Over voltage alarm LED is annunciated on associated 2V164 • Confirm operation of the Over voltage alarm output 	

Item	Description	Complete
22	Supplementary Checks (Where function is implemented) : Under voltage block <ul style="list-style-type: none"> • For each rack undertake secondary voltage injection below the Under-voltage block setpoint • Confirm Blocking LED is annunciated on associated 2V164 • Confirm operation of the Under-voltage block output 	
23	Supplementary Checks (Where function is implemented) : Tap change fail alarm <ul style="list-style-type: none"> • Isolate the Tap Raise and Tap Lower outputs to the tap changer mechanism • For each rack undertake secondary voltage injection out of band and await the expiry of the tap fail delay • Confirm T/C Fail LED is annunciated on associated 2V164 • Confirm operation of the Tap change fail alarm output • Place all racks to the off mode and restore the Tap Raise and Tap Lower outputs 	
24	Supplementary Checks (Where function is implemented) : Tap rate alarm <ul style="list-style-type: none"> • For each rack undertake secondary voltage injection out of band to cause a number tap changes exceeding the Tap Rate Alarm /Hr setting • Confirm Tap Rate Alarm LED is annunciated on associated 2V164 • Confirm operation of the Tap rate alarm output • Adjust the injected secondary voltage to within band to cease tap change operations • Adjust the Tap Rate Alarm /Hr setting to beyond the previous alarm point • Confirm Tap Rate Alarm LED is extinguished on associated 2V164 • Confirm drop out of the Tap rate alarm output 	

Item	Description	Complete
25	<p>Supplementary Checks (Where function is implemented) :</p> <p>Power supply/CPU fail alarm (wired to normally closed contact, with relays powered up and healthy this contact will be open)</p> <ul style="list-style-type: none"> • With each rack powered up and healthy • Confirm Power supply/CPU fail alarm contact is open • Withdraw the 1X200 relay module from its case • Confirm that the Power supply/CPU fail alarm output contact closes • Re insert the 1X200 relay module into its case • Confirm that the Power supply/CPU fail alarm output contact opens • Repeat above in turn with 2V164 (instead of 1X200) and then in turn with the 2V165 (instead of 1X200) 	

Transformer Off Load Checks

The following tests are undertaken following the satisfactory completion of the Pre Site Commissioning Verification Checklist.

As a precaution it is recommended that the following tests are undertaken Off Load so that any inadvertent voltage deviation (Over voltage or Under Voltage) will not cause adverse effect to connected customers or equipment.

With the transformers energised via their primary windings and Off Load.

Transformers must not be in parallel during these tests.

It is assumed that the measuring VTs will be fed by the off loaded transformers.

Item	Description	Complete
1	On each 1M122 rack switch to Manual Mode and Raise Taps <ul style="list-style-type: none"> • Confirm TPI indication on both the 2V164 and 2V165 is correct and corresponds to the physical tap position of the tap changer • Raise tap position a number of times and each time confirm TPI indication is consistent with the physical tap position of the tap changer 	
2	On each 1M122 rack switch to Manual Mode and Lower Taps <ul style="list-style-type: none"> • Confirm TPI indication on both the 2V164 and 2V165 is correct and corresponds to the physical tap position of the tap changer • Lower tap position a number of times and each time confirm TPI indication is consistent with the physical tap position of the tap changer 	
3	On each 1M122 rack confirm correct voltage is displayed according to other instrumentation on site or according to transformation ratio and the primary measured voltage	

Item	Description	Complete
4	Switch each 1M122 rack to Auto-Independent Mode <ul style="list-style-type: none"> • Confirm TPI indication on both the 2V164 and 2V165 is correct and corresponds to the physical tap position of the tap changer • Lower the Voltage setpoint on each 2V164 to cause a tapping operation on the specific transformer • confirm TPI indication is consistent with the physical tap position of the tap changer • Raise the Voltage setpoint on each 2V164 to cause a tapping operation on the specific transformer • confirm TPI indication is consistent with the physical tap position of the tap changer 	
5	Switch each 1M122 rack to Manual Mode <ul style="list-style-type: none"> • Adjust all transformers to a common tap position • Switch each 1M122 rack to Auto-Follower Mode • Switch one 1M122 rack to Auto-Master Mode Confirm TPI indication on both the 2V164 and 2V165 is correct and corresponds to the physical tap position of the tap changers • Lower the Voltage setpoint on the Auto-Master 2V164 to cause a tapping operation • Confirm tapping occurs on all transformers • Confirm TPI indications are consistent with the physical tap position of the tap changers • Raise the Voltage setpoint on the Auto-Master 2V164 to cause a tapping operation • Confirm tapping occurs on all transformers • Confirm TPI indications are consistent with the physical tap position of the tap changers • In turn select a different 1M122 rack to the Auto-Master mode and repeat above tests 	

As an alternative the transformers may be back energised via their secondary winding and kept Off Load by having the primary transformer connections isolated from the primary voltage supply, this will cater for VTs connected outside of the Transformer switching zone.

Transformer On Load Checks

The following tests are undertaken following the satisfactory completion of the Pre Site Commissioning Verification Checklist and Transformer Off Load Checks.

Item	Description	Complete
1	<p>Place one of the 1M122 racks into Auto-Master Mode and the remaining racks in Auto-Follower Mode</p> <ul style="list-style-type: none"> • Confirm TPI indication on all the 2V164s and 2V165s is correct and corresponds to the physical tap position of the tap changer • Lower the Voltage setpoint on the Auto-Master 2V164 to cause no more than one tapping operation on all the transformers • Confirm TPI indication is consistent with the physical tap position of the tap changer • Raise the Voltage setpoint on the Auto-Master 2V164 to cause no more than one tapping operation on all the transformers • Confirm TPI indication on both the 2V164 and 2V165 is correct and corresponds to the physical tap position of the tap changer following any tapping • Repeat above tests for the other 1M122 racks set in Auto-Master Mode • Restore all Voltage Setpoints to required setting on completion of tests 	

Decommissioning & Disposal

Decommissioning: The auxiliary supply circuit in the relay may include capacitors across the supply or to earth. To avoid electric shock or energy hazards, after completely isolating the supplies to the relay (both poles of any dc supply), the capacitors should be safely discharged via the external terminals prior to decommissioning.

Disposal: It is recommended that incineration and disposal to water courses is avoided. The product should be disposed of in a safe manner.

Maintenance

Mechanical Inspection

Relay Assembly

Inspect the relay for obvious signs of damage or ingress of moisture or other contamination.

Relay Module

Isolate the relay, remove the front cover & carefully withdraw the relay module from the case.

Care must be taken to avoid subjecting the relay element to static discharge which may damage or degrade sensitive electronic components.

Inspect the relay module for signs of any overheating or burn marks which may have been caused by overvoltage surge or transient conditions on the power supply or digital status inputs.

Inspect the VT & CT stages for degradation of insulation on the terminal wiring & transformer windings.

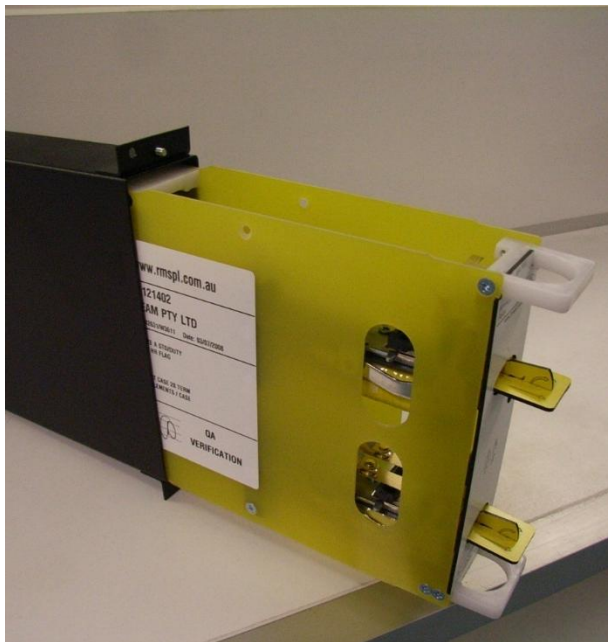

Remove cover by unscrewing black thumb screws & withdraw the relay module from the case.

Relay Case

Inspect the outer terminals checking insulation integrity & tightness.

Inspect inside the case and use a blower to remove dust.

Inspect the inner terminals for worn, distorted or tarnished contacts and if necessary clean the contacts using a brush dipped in a suitable substance.

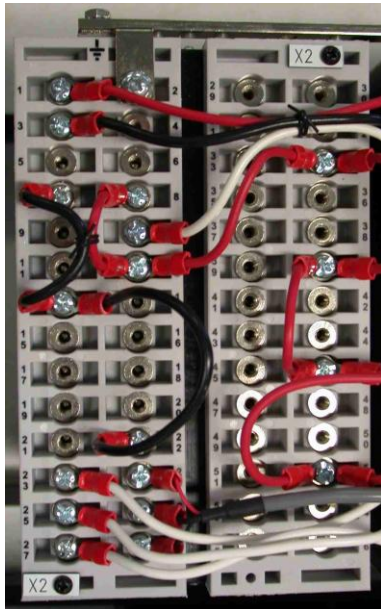

Case outer terminals



Case inner terminals



Module plug in terminals

Test Intervals

The maintenance tests required will largely depend upon experience and site conditions, but as a general rule it is recommended that the following inspection and tests are performed every twelve months.

- ◆ Mechanical Inspection
- ◆ Check of Connections
- ◆ Insulation Resistance Test
- ◆ Fault Setting Tests by Secondary Injection
- ◆ Tests using Load Current
- ◆ Check the continuity of the neutral CT loop with a bell test set or an ohmmeter

Defect Report Form

Please copy this sheet and use it to report any defect which may occur.

Customers Name & Address:	Contact Name:
	Telephone No:
	Fax No:
Supplied by:	Date when installed:
Site:	Circuit:

When Defect Found

Date:	Commissioning?	Maintenance?	Systems Fault?	Other, Please State:
Product Part No:			Serial Number:	
Copy any message displayed by the relay:				
Describe Defect:				
Describe any other action taken:				
Signature:		Please Print Name:		Date:

For RMS use only

Date Received:	Contact Name:	Reference No:	Date Acknowledged:	Date of Reply:	Date Cleared:
----------------	---------------	---------------	--------------------	----------------	---------------