



Features

- Compact rugged design
- One or two optical detectors
- High speed arc detection
- Heavy duty 6m termination cable
- Optional 20m & screened cables
- Simple flush panel mounting outside or inside switchgear compartment
- Integrated sensor circuit supervision
- Very low sensitivity to ambient light levels to avoid nuisance tripping even in direct sunlight
- Sealed module for harsh environments
- Optional metal reinforced mounting shield

Application

Arc fault protection is a relatively new technique employed for the fast clearance of arcing faults on BUS bars & within metal clad switchgear & associated cable boxes. The arc is detected using an optical sensor & the signal input to a protection device which also monitors the load current on the system. A trip signal can be achieved in less than 10ms using arc detection.

RMS manufactures a protection class arc fault optical sensor & monitoring system suitable for both low & medium voltage switchgear and BUS bar applications.

- 1S20** 3 sensor, 2 zone Arc Fault Monitor
- 1S25** 8 sensor, 4 zone Arc Fault Monitor
- 1S26** 1S25 with integrated current check
- 1S30** Optical Arc Fault Sensor

While the high intensity flash caused by an electrical arc will be reflected within the metal clad switchgear, it is recommended that one or more sensors be mounted in each enclosed switchgear compartment.

For BUS bar protection applications multiple sensors are required to achieve adequate coverage along the length of the BUS. A sensor version with two optical detectors "looking" in opposite directions is available for this purpose (Refer figure 3 for generic layout).



1S30 Arc Fault Sensors

Through panel mounting detector
View depicted at left

Front panel view of dual detector
version depicted at right

Description

Made in Australia

The 1S30 is an optical sensor that responds to the flash of light emitted during the incidence of an arcing fault. Onset of the light flash & detection by the 1S30 occurs in a few ms.

Each arc fault sensor consists of one or two silicon PIN photo diode light detectors mounted on a circuit board together with the associated detection circuit (Figures 1 & 2). The detector monitors a wide space angle. A broad spectral response in the visible region is provided as depicted in figure 5.

Sensitivity of the arc sensor has been set to a low level to reduce the possibility of mal operation under high ambient lighting conditions. This is made possible due the high intensity of light emitted under arc fault conditions. Additional security can be incorporated by way of a current check stage as described in the 1S20 Arc Fault Monitor Technical Bulletin.

In stand by mode the 1S30 sensor presents a high resistance to the 12V DC control signal provided by the 1S20, 1S25 or 1S26 Arc Fault Monitors. This allows a small circulating current to flow for continuous supervision of the 1S30 connection circuit. When an arc is detected, the resistance presented by the 1S30 drops to a level where the current flow increases to approximately 20mA. This increased current flow is instantaneously detected by the Arc Fault Monitor & its trip output contacts closed. Refer to the 1S20 Arc Fault Monitor Technical Bulletin for further details.



SINGLE DETECTOR PACKAGE

Figure 1 depicts the 1S30 with a single optical detector. Note the window where the active part of the detector is positioned to. This permits convenient mounting on the outside of the panel with the detector window protruding a hole in the panel.

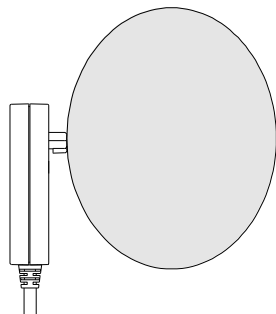

Figure 1:

DUAL DETECTOR PACKAGE

Figure 2 depicts the 1S30 with dual optical detectors. The two optical detectors face in opposite directions to provide arc detection coverage in both directions. This version is particularly useful when mounted in a BUS chamber or barrier between adjacent switchgear chambers. The main benefits are reduced cost compared to two separate sensors & use of only one input channel on the 1S20 Arc Fault Monitor.

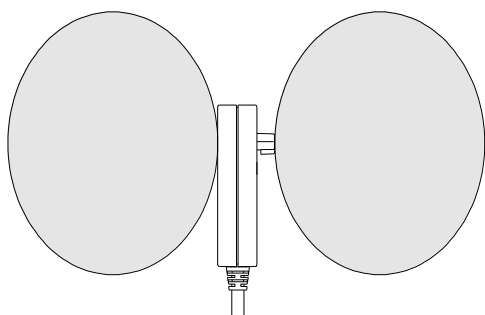

Figure 2:

DETECTOR RANGE

A detection range along the 100% relative sensitivity curve shown in figure 3 is approximately 3m. Single detector versions therefore need to be placed at a maximum spacing of 5-6m. The dual detector versions may be placed at a maximum spacing of 5-6m to provide adequate detection overlap. In switchgear the light caused by the arc is reflected from the walls & therefore, the mounting of the sensor is not critical.

While the high intensity flash caused by an electrical arc will be reflected within the metal clad switchgear, it is recommended that one or more sensors be mounted in each enclosed switchgear compartment.

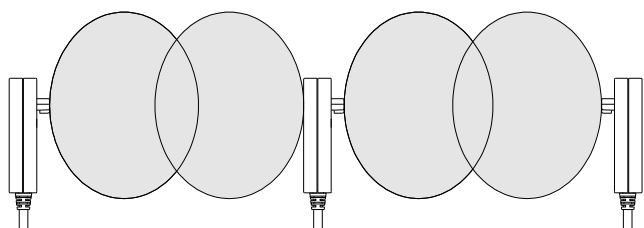

Figure 3:

Detector Characteristics

OPTICAL SENSITIVITY

~10,000 Lux* for white light at normal incidence to the detector window(s) as depicted in figure 4:

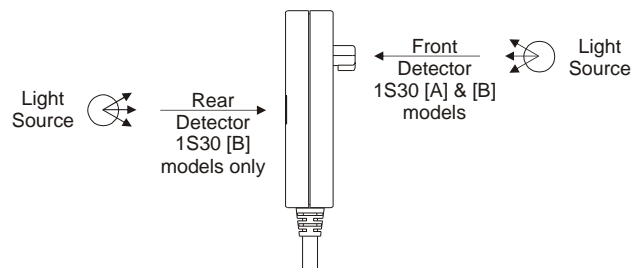

Figure 4:

For the 1S30-A single detector version the front detector only is fitted. In this configuration the 1S30-A will be insensitive to white light incident on the rear surface of the case up to a level of 200,000 Lux.

As the illuminance of diffuse ambient sunlight falls in the range 5,000 to 10,000 Lux, this will not normally be sufficient to trigger the 1S30 sensor. The luminous intensity from the sun at noon at the equator however is ~100,000 Lux which will be sufficient to trigger the 1S30 sensor so measures should be made to avoid this situation.

Direct sunlight incident on the rear of the 1S30-A model sensor will not cause it to pick up. This attribute provides a significant safety margin to avoid nuisance tripping when the option of mounting the sensor externally on switchgear as depicted in figure 6 is employed.

DETECTOR DIRECTIONAL CHARACTERISTICS

Detector sensitivity falls to ~40% of the nominal level at inclination angles up to 70 degrees from the normal for white light.

DETECTOR SPECTRAL RESPONSE

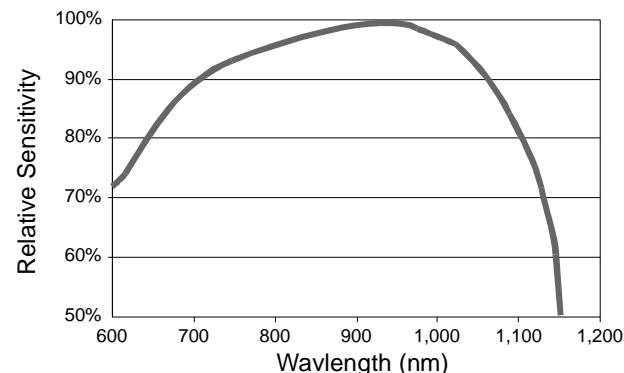

Figure 5:
Arc detector spectral response

* Due to the relatively high sensitivity of the detector to IR wavelengths the type of light source employed for sensitivity testing will have a major effect on the results obtained. Sensitivity testing should therefore be conducted using a 50-75W halogen lamp with an integrated aluminum reflector.



Mounting Options

FLUSH PANEL MOUNTING

The 1S30 is suitable for flush panel mounting in a number of configurations.

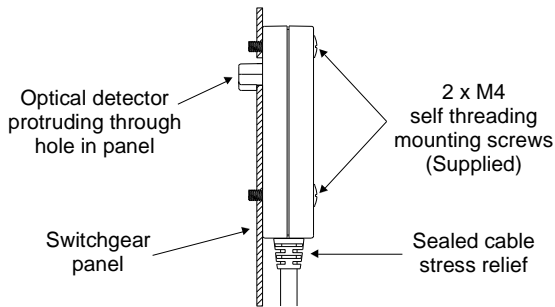

Figure 6:

1S30 shown mounted on the outside of a switchgear panel
Detector oriented to 'look' through a hole into the switchgear

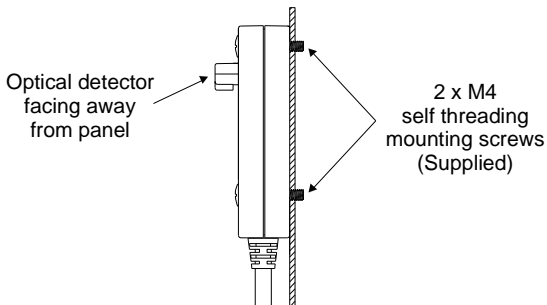

Figure 7:

1S30 shown mounted on the inside of a switchgear panel
Detector oriented to 'look' out into the switchgear compartment

FLUSH MOUNT REINFORCING PLATE

When mounting the 1S30 on the outside of a switchgear cubicle as depicted in figure 6, the hole required in the panel may degrade the short circuit rating. If this is considered to be an issue then a reinforcing plate may be fitted over the 1S30 as depicted below.

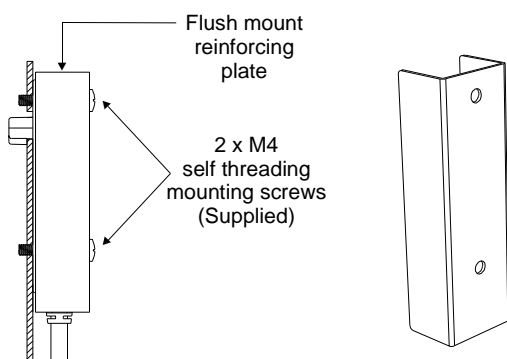

Figure 8:

Flush mount reinforcing plate
1.2mm zinc plated mild steel

DUAL DETECTOR VERSION

The dual detector version can be panel mounted to monitor two adjacent switchgear compartments simultaneously. This feature can be used to reduce the total cost for sensors or to increase the monitoring coverage for each 1S20 Arc Fault Monitor unit.

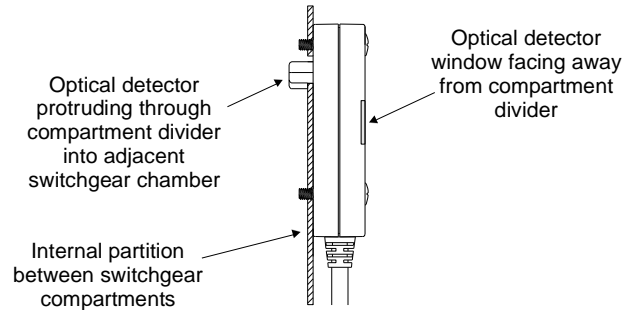

Figure 9:

1S30 shown mounted on the inside of a switchgear panel
This configuration combines the functions described in Figures 6 & 7 with the application of a single dual detector arc fault sensor

PANEL MOUNT CUT OUT DETAIL

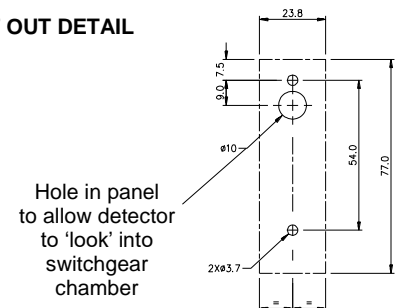

Figure 10:

Flush mounting detail

RIGHT ANGLE MOUNTING OFF A SURFACE

A right angle mounting bracket may be fabricated using the panel cut out detail in figure 10. Single & dual detector models may be mounted in this manner as depicted below.

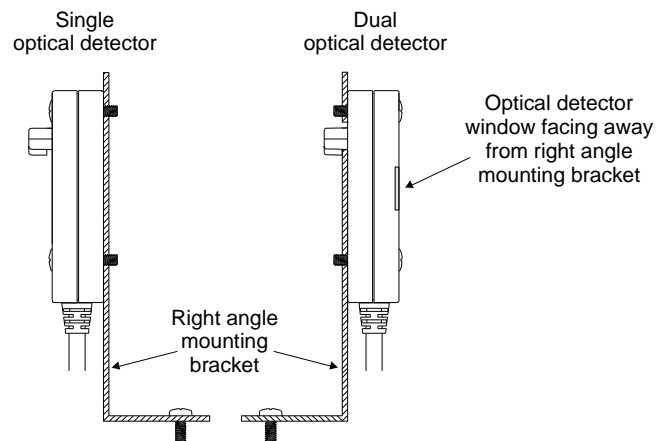

Figure 11:

Right angle mounting off a surface
Mount off floor or walls within switchgear / BUS bar chamber



Technical Data

ARC FAULT PROTECTION SCHEME

Refer to the 1S20 Technical Bulletin for further details.

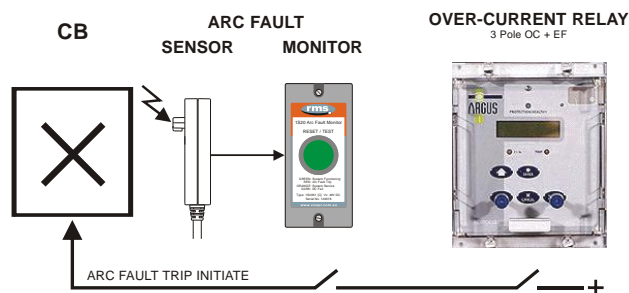

Figure 12:

Key components required to implement an Arc Fault Protection scheme with an overcurrent check stage to enhance system security

ARC PROTECTION SCHEME OPERATE TIME

The total time required for detection of the arc flash to closure of the 1S20 Arc Fault Monitor trip contacts is less than 10ms including bounce. Typical operate time is 7 to 8ms.

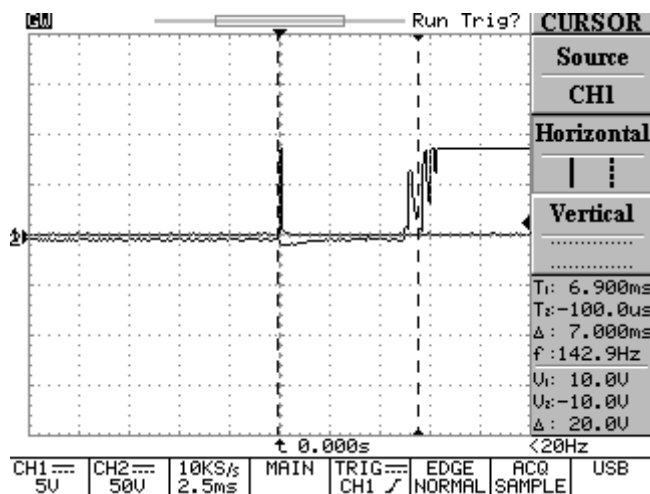

Figure 13:

CRO trace showing nominal operation time of the trip contacts at 7ms. First contact touch at 6.25ms and fully closed by 7.25ms. Operation in <10ms is considered acceptable as current check relay operate time is ~15ms.

MINIMUM ARC DURATION

The minimum arc "flash" duration required to guarantee operation of the Arc Fault Monitors output contacts is 2.2ms.

AUXILIARY SUPPLY

Voltage from 1S20 Arc Fault Monitor: 12V DC
Power consumption: ≤2.5mA

CASING

Rugged moulded construction to IP51.

TEMPERATURE RANGE

Operating: -5 to +55°C
Storage: -25 to +75°C

SENSOR CONNECTIONS

The 1S30 is supplied with a 6m two core connection cable as standard. Two core multi strand wire (2x16/0.2mm), is supplied stripped & pre tinned at the 1S20 connection end. The standard 6m cable may be cut down to the desired length & crimp ring lugs fitted for termination to the 1S20, 1S25 or 1S26 Arc Fault Monitors.

The 1S30 connections are not polarity sensitive. Reversal of the wires on the arc monitor terminals has no effect on the performance of the 1S30 or arc detection system.

The cable is factory fitted to the 1S30 Arc Fault Sensor using a stress relief molding to provide a sealed & durable connection interface. The cable employs thick inner & outer insulation layers to avoid damage during installation.

For connection over longer distances shielded cable is recommended. For distances over 20m, 24/0.2 mm cable should be employed.

ADDITIONAL 1S30 CABLE LENGTH

Screened arc sensor cables may be increased by wiring additional series twisted pair SCREENED cable provided it does not exceed 5 ohms and 30nF loop impedance.

ARC SENSOR SHIELD WIRE EARTH CONNECTION

The arc sensor shield wire(s) should be connected to ground as detailed in figures 14 to 16.

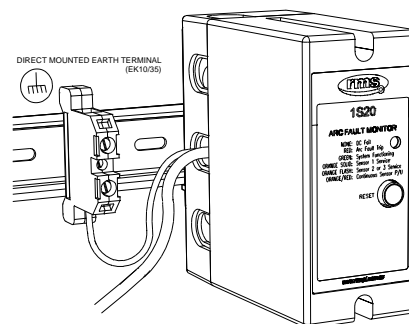

Figure 14: 1S20 DIN rail mount earth connection detail

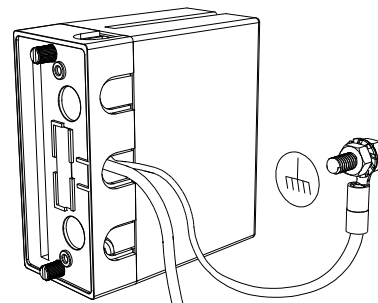

Figure 15: 1S20 panel mount earth connection detail

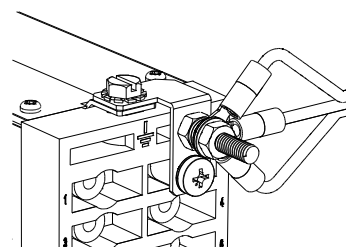

Figure 16: M Series case type earth connection detail



Ordering Information

The following accessories are available separately:

220 100 500 1S30 Flush mount reinforcing plate

Generate the required ordering code as follows: e.g. 1S30-A-

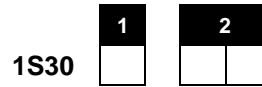

1 DETECTORS

- A Single through hole panel detector
- B Dual detectors

2 SPECIFY OPTIONS

- 6m unshielded cable (Standard)
- F Flush mount reinforcing plate required
- S 6m shielded cable required
- L 20m shielded cable required

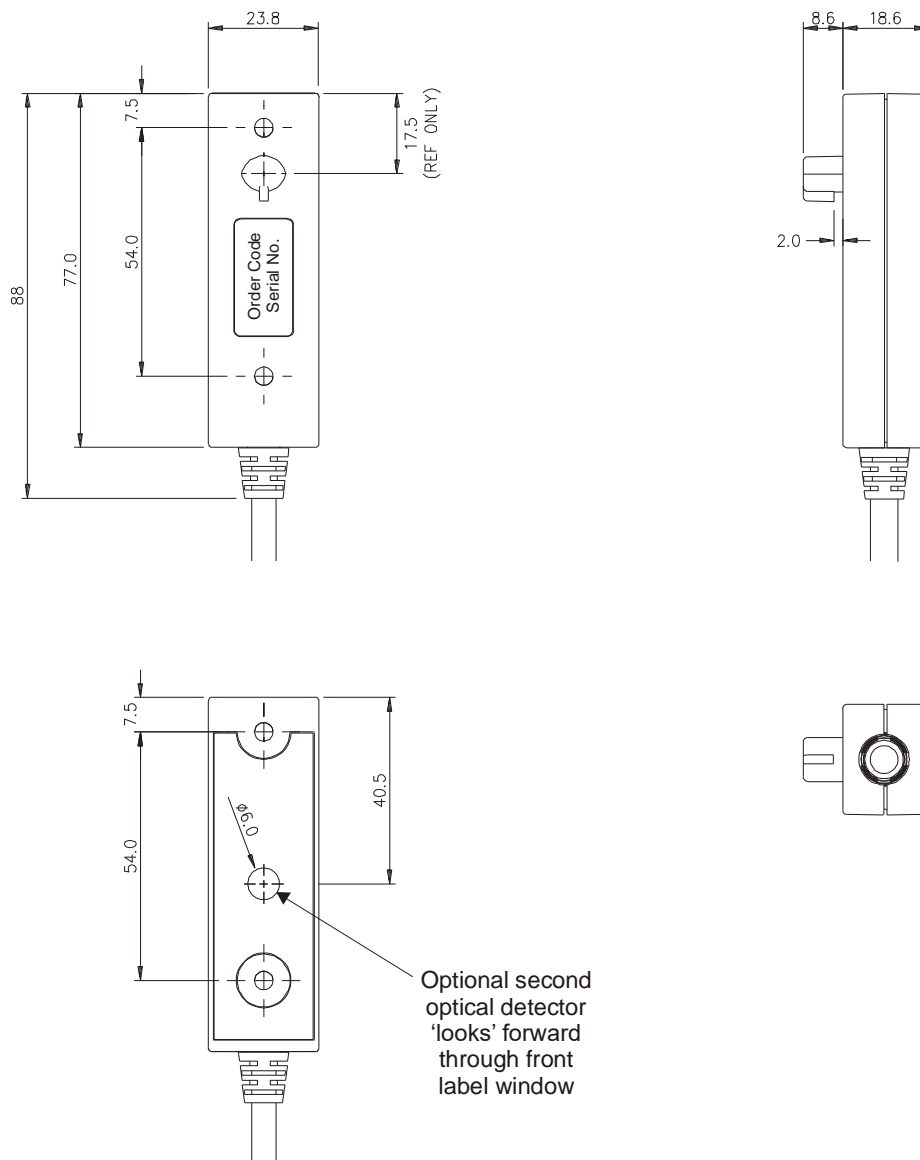

Figure 17: 1S30 Arc Fault Sensor dimensions



RMS Mors Smitt
A *Wabtec* Company

RMS Mors Smitt
19 Southern Court
Keysborough, VIC 3173, Australia
Tel: +61 (0)3 8544 1200
sales.rms@wabtec.com

Wabtec Netherlands B.V.
Darwinstraat 10
6718 XR Ede, Netherlands
Tel: +31 (0)88 600 4500
wnl_salessupport@wabtec.com



RMS Mors Smitt
A *Wabtec* Company



Visit www.morssmitt.com/rms for the latest product information.
Due to RMS continuous product improvement policy this information is subject to change without notice.

