

Definite Time Current Check Relay

Features

- 10:1 PU setting ranges
Select from two options:
5 - 50% or 20 - 200% of nominal input current
- 1A or 5A nominal CT's
- Fast reset times (<15ms at 20x setting, repeated offset)
- <5% transient over-reach
- 2 N/O & 2 N/C time delayed output contacts
- 3 extra configurable C/O contacts (Time delayed or inst. phase segregated)
- 0 to 99s time delayed output with $\pm 0.5\%$ accuracy
- Time settings easily selected by digital thumb wheel switches
- Timing in progress LED
- Optional internal timer initiate input logic
- Hand & remote flag reset
- 40-300V DC auxiliary supply
Power supply fail relay drops out if the Auxiliary supply fails.
- Optional 20-70V DC supply
- Size 4M draw out case

Application

The 2C63 Series relays are adjustable AC current sensing relays designed for high or low voltage power systems where they can be used in a large number of overcurrent applications.

Definite time overcurrent relays offer advantages over inverse time protection in power systems which have a wide variation in source impedance. Faults can be cleared in relatively short times irrespective of the magnitude of the fault current, & coordination of several relays in a system can be obtained at all times regardless of fault current variation.

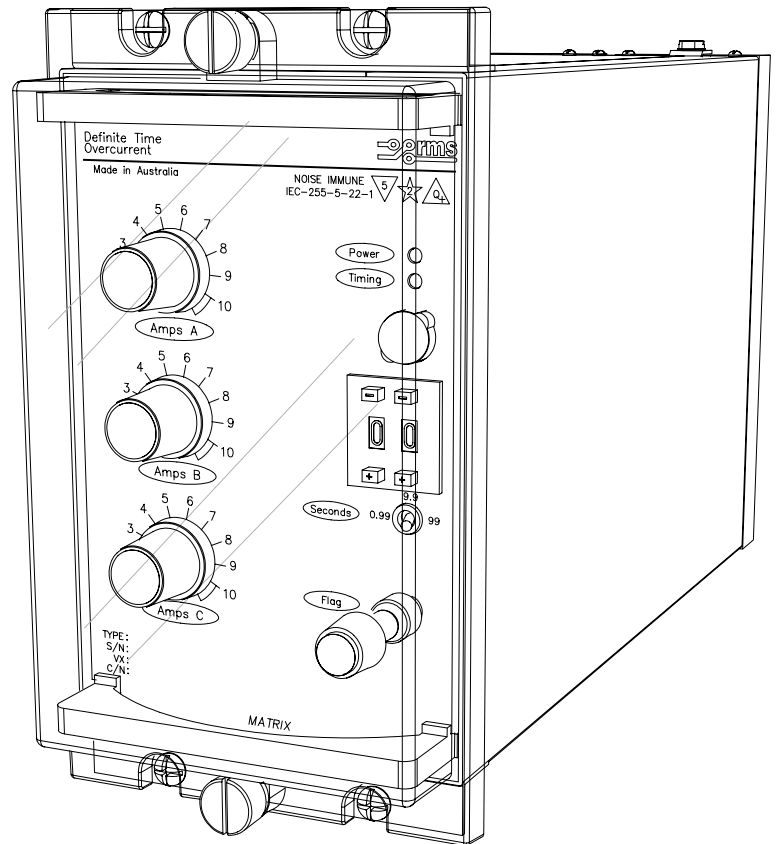

2C63 in a 4M56 case

Operation

Made in Australia

The 2C63 Series relay is a three pole unit fitted with independently adjustable current sensing circuits driving a common adjustable digital setting timing element with two N/O & two N/C self reset output contacts. Three additional C/O self reset output contacts can be configured for either instantaneous (One for each phase) or time delayed operation. A relay initiate input is provided for the time delayed element.

The internal time delay element is initiated when both the current exceeds the user selectable setting & the relay initiate input is energized. An optional internal timer initiate status input may be specified to allow timer operation in the absence of P/U current.

After pick up & time out the latching target indicator may be hand reset at the front panel or remotely reset via a status input.

Fully solid state sensing & measuring circuitry is employed with each phase current setting continuously adjustable on a front panel control. Air core CT's are employed to provide very fast reset characteristic.

The wide range switchmode power supply, input current transformer, output relays & status inputs form the essential barriers against high voltage line transients.

Instantaneous Relay

The 2C64 instantaneous current check relay may be specified where an integrated delay timer is not required. This relay has identical performance characteristics to the 2C63 less the time delay function.

Zero Stand by Burden Relay

The 2C80 current check relay may be specified where a zero stand by burden is required. Initiation of the relay is achieved through application of the auxiliary supply on a single or three phase basis. The linear power supply provides high speed start up but results in higher operating burden & non continuous rating. The 2C80 may be specified with or without an integrated time delay element.

CONFIGURABLE PHASE OUTPUT CONTACTS

In addition to the timed output contacts, three additional C/O contacts are provided which can be configured to operate as follows:

- Instantaneous or time delayed
- Phase segregated or common

The function of these contacts may be specified at time of order as per the ordering information on page 3. Alternatively the configuration can be changed in the field by withdrawing the relay module from the case & changing the internal configuration jumpers as shown below.

PHASE OUTPUT CONTACT PICK UP REQUIREMENTS

Each phase output relay has two jumpers associated which can be independently set. The condition to be met for each phase output relay to pick up is determined by the jumper settings for that relay as per the following table:

| Output Delay | Output Function per Phase | |
|---------------|--|---|
| | Common Output | Phase Segregated |
| Instantaneous | Current picked up on any phase JMP-X to 2-3 JMP-Y to 2-3 | Current picked up on that phase JMP-X to 2-3 JMP-Y to 1-2 |
| Time delayed | Time delayed outputs picked up JMP-X to 1-2 JMP-Y to 2-3 | Phase segregated time delayed trip function not available. |

PHASE OUTPUT CONFIGURATION SETTINGS

One pair of jumpers are provided for each phase which may be set independently.

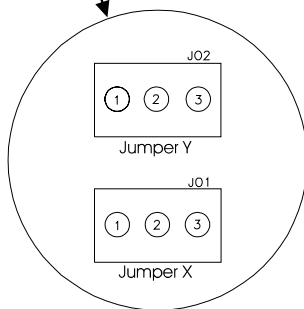
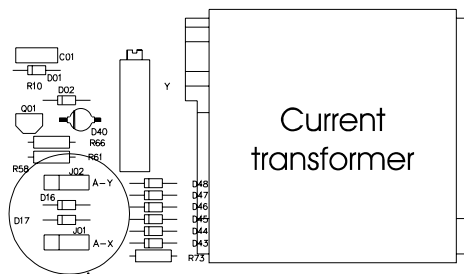

| PHASE | JMP-X | | JMP-Y | |
|-------|-------|------|-------|------|
| | INST. | DLY. | COM. | SEP. |
| A | 2-3 | 1-2 | 2-3 | 1-2 |
| B | 2-3 | 1-2 | 2-3 | 1-2 |
| C | 2-3 | 1-2 | 2-3 | 1-2 |

Operating Logic

RELAY INITIATE LOGIC

This is the most common mode of operation for the time delayed output contacts. The internal timer is only initiated when both the current exceeds the user selectable setting & a voltage is applied to the relay initiate status input.

Contacts configured for instantaneous operation will always operate when the current exceeds the user selectable setting irrespective of the status of the relay initiate status input.

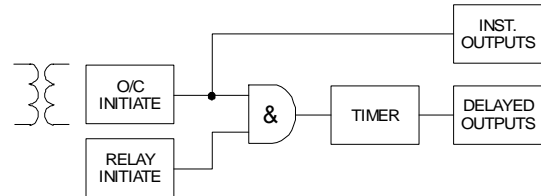

INTERNAL TIMER INITIATE STATUS INPUT

When this version is specified in the ordering code, an additional status input is provided for initiating the internal time delay element. With this version the internal timer can be initiated in two ways:

1. If the current exceeds the user selectable setting & a voltage is applied to the relay initiate status input;
2. If a voltage is applied to both the relay initiate status input & the timer initiate status input.

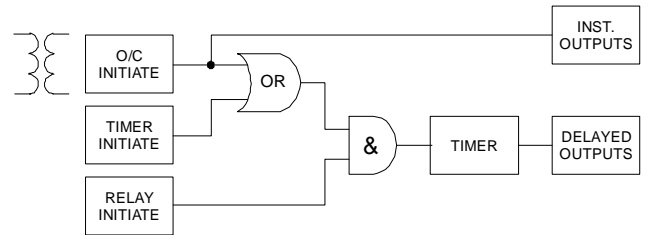

DELAYED OUTPUT CONTACTS

Two (2) N/O & two (2) N/C time delayed self reset contacts plus three (3) configurable self reset C/O contacts (Schrack type). (Refer ordering information for details).

IDEC RH1 OUTPUT CONTACT RATINGS

Maximum Contact Capacity (Amps)

| Voltage | DC | | | AC | | |
|-------------------|-----|-----|-----|-----|-----|-----|
| | 30 | 125 | 250 | 110 | 220 | 250 |
| Resistive | 10 | 2.4 | 1.2 | 10 | 7 | 6.6 |
| Inductive L/R 7ms | 7.5 | 1.8 | 0.9 | 7.5 | 5 | 4.4 |

Make & Carry for 200ms

30A at 250V DC resistive

Maximum Break Capacity

0.34A at 250V DC inductive (40ms)

CONFIGURABLE OUTPUT CONTACT RATINGS

Make & carry

30A AC or DC (Limits L/R=40ms & 300V max.) for 0.2s
20A AC or DC (Limits L/R=40ms & 300V max.) for 0.5s
5A AC or DC continuously

Break (Limits 5A & 300V max.)

1,250VA AC resistive
250VA at 0.4PF AC inductive
75W DC resistive
30W DC inductive L/R = 40ms
50W DC inductive L/R = 10ms

Minimum recommended load

0.5W, 10mA or 5V minimum.

BURDENS

Auxiliary supply: (at 110V DC nominal supply)
 Less than 3 watts during timing.
 Less than 6 watts with output relays energized.

Sensing circuits: VA per phase all settings.

| I amps | 1A CT input | 5A CT input |
|--------|-------------|-------------|
| 1 | 1.25 | 0.01 |
| 5 | 6 | 0.18 |
| 10 | 25 | 0.70 |
| 20 | 100 | 2.9 |
| 25 | - | 4.5 |
| 30 | - | 6.5 |

CT INPUT THERMAL WITHSTAND (Per phase)

| | 1A CT | 5A CT * |
|------------|-------|---------|
| Continuous | 3.5 | 25 |
| 4.5s | 39 | 250 |
| 3s | 75 | 450 |
| 2s | 90 | 550 |
| 1s | 120 | 800 |
| 0.5s | 180 | 1,000 |

Note: * M Series case terminals & CT shorting switches are limited to 400A for 1s.

AUXILIARY SUPPLY

40 – 275V AC & 40-300V DC switchmode supply with power on LED
 20 – 70V DC switchmode supply with power on LED.

POWER SUPPLY FAIL ALARM CONTACT

One C/O contact picked up when auxiliary supply healthy. (Schrack type).

DROPOUT PICKUP RATIO

85% approximately.

OPERATING TIME OF INSTANTANEOUS CURRENT ELEMENT

At 2 X Setting: Less than 20ms on pick up.
 Drop out less than 15 ms when:

- Relay is energized by symmetrical or fully offset current of either polarity, or by three successive applications of fully offset currents of same polarity with time interval of not less than 5 sec between each application. (Current duration of 5 cycles).
- Steady state current magnitudes up to 20 x setting are switched off at or near a current zero with the current prior to switch off being + ve going, & at or near a current zero with the current prior to switch off being -ve going. (X/R ratios of the circuit from which the relay is energized lie in the range 10 to 30).

TIMING FUNCTION

Refer to 2T104 data sheet (Instantaneous reset version) for timing function specifications.

ACCURACY OF SETTINGS

Repeatability: ± 2% of setting
 Setting: ± 5% of maximum setting

OPERATION INDICATOR

A red LED provides indication that the relay is timing
 A magnetic disc (permanent memory) indicator with hand reset provides indication after time delayed operation.

REMOTE FLAG RESET FUNCTION

Application of a control voltage to the optional remote flag reset input will cause the bistable flag to be reset.

INSULATION WITHSTAND

IEC60255-5 2KV RMS & 1.2/50 5KV impulse between:

- all input terminals & frame
- all output terminals & frame
- all input & output terminals
- each input group
- each output group

HIGH FREQUENCY DISTURBANCE

IEC60255-22-1 2.5KV 1MHz common mode
 1.0KV 1MHz differential mode

ELECTROSTATIC DISCHARGE

EN61000-4-2:1995 8KV Level 3

RADIO FREQUENCY INTERFERENCE

EN61000-4-3:1995 10V/m Level 3

FAST TRANSIENT DISTURBANCE

EN61000-4-4:1995 4KV Level 4

AMBIENT OPERATING TEMPERATURE RANGE

-5 to 55 degrees C.

HUMIDITY

40 degrees C & 95% RH non condensing

CASE

Size 4 draw out
 28 M4 screw terminals
 Flush panel mount or 4U high 1/4 width 19 inch rack mount
 IP51 rating

SHIPPING DETAILS

Each relay is supplied individually packed in pre formed cardboard cartons with internal moulded polystyrene former.

Weight: 3.3Kg

Size: 370(L) x 240(W) x 145(D)mm - Size 4 case

ACCESSORIES SUPPLIED WITH EACH RELAY

1 x M4 self threading mounting screw kit P/N 290-406-151
 2 x M4 terminal screw kit (28 per kit) P/N 290-407-153

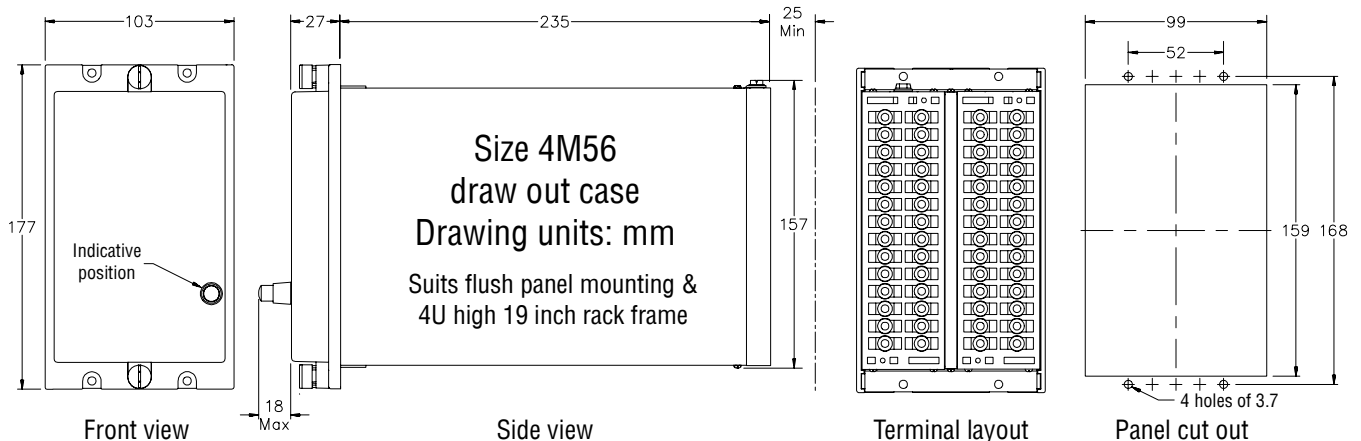

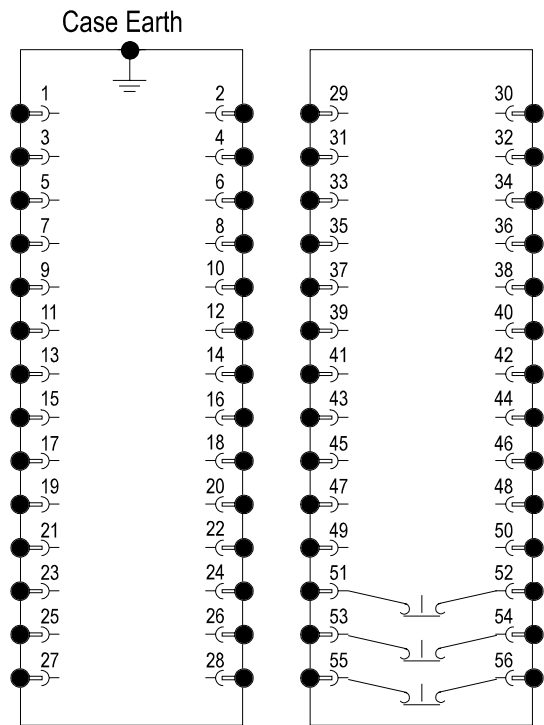

4M56 Case terminations (REAR VIEW)

Ordering Information

Generate the required ordering code as follows: e.g. 2C63 BAABBBH

2C63 1 2 3 4 5 6 7

1 AUXILIARY SUPPLY RANGE

- A 20-70V DC
- B 40-275V AC / 40-300V DC

2 CURRENT SETTING (% of nominal)

- A 5-50%
- B 20-200%

3 CT RATING (Nominal)

- A 1A
- B 5A

4 RELAY INITIATE STATUS INPUT

- | Opto-isolated input | Relay coil input |
|---------------------|------------------|
| A 24-80V DC | D 12V DC |
| B 75-150V DC | E 24V DC |
| C 150-300V DC | F 48V DC |
| | G 110V DC |

5 REMOTE FLAG RESET INPUT

- | Opto-isolated input | Relay coil input |
|---------------------|------------------|
| A 24-80V DC | D 12V DC |
| B 75-150V DC | E 24V DC |
| C 150-300V DC | F 48V DC |
| | G 110V DC |

6 CONFIGURABLE OUTPUT CONTACTS

- A 3 C/O 3 ϕ time delayed output
- B 3 C/O 3 ϕ instantaneous output
- C 3 x 1 C/O instantaneous phase segregated

7 INTERNAL TIMER INITIATE STATUS INPUT

- H Not required (Refer operating logic section)

- | Opto-isolated input | Relay coil input |
|---------------------|------------------|
| A 24-80V DC | D 12V DC |
| B 75-150V DC | E 24V DC |
| C 150-300V DC | F 48V DC |
| | G 110V DC |

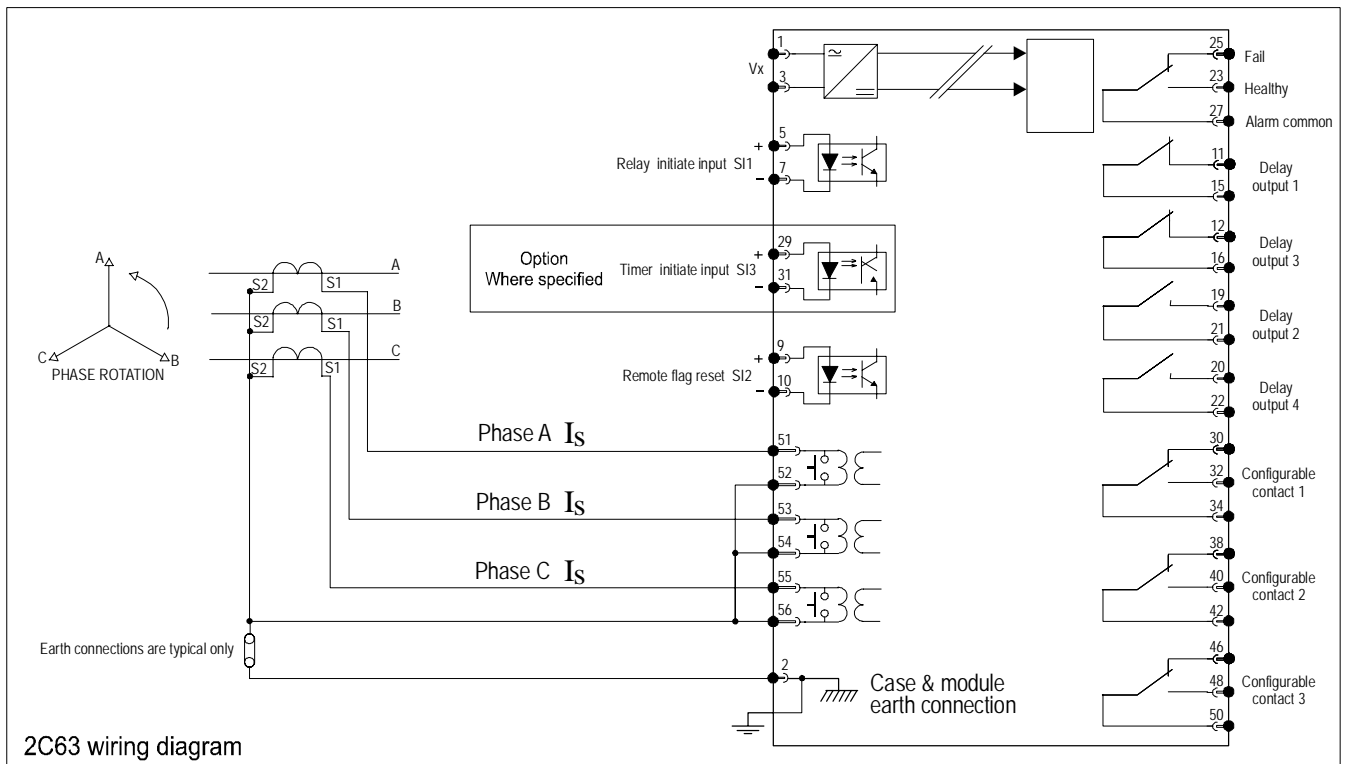

2C63 wiring diagram

Australian Content

Unless otherwise stated the product(s) quoted are manufactured by RMS at our production facility in Melbourne Australia. Approximately 60% of our sales volume is derived from equipment manufactured in house with a local content close to 90%. Imported components such as semi-conductors are sourced from local suppliers & preference is given for reasonable stock holding to support our build requirements.

Quality Assurance

RMS holds NCSI (NATA Certification Services International), registration number 6869 for the certification of a quality assurance system to AS/NZS ISO9001-2000. Quality plans for all products involve 100% inspection and testing carried out before despatch. Further details on specific test plans, quality policy & procedures may be found in section A4 of the RMS product catalogue.

Product Packaging

Protection relays are supplied in secure individual packing cardboard boxes with moulded styrene inserts suitable for recycling. Each product & packing box is labeled with the product part number, customer name & order details.

Design References

The products & components produced by RMS are based on many years of field experience since Relays Pty Ltd was formed in 1955. A large population of equipment is in service throughout Australia, New Zealand, South Africa & South East Asia attesting to this fact. Specific product & customer reference sites may be provided on application.

Product Warranty

All utility grade protection & auxiliary relay products, unless otherwise stated, are warranted for a period of 24 months from shipment for materials & labour on a return to factory basis. Repair of products damaged through poor application or circumstances outside the product ratings will be carried out at the customer's expense.

Standard Conditions of Sale

Unless otherwise agreed RMS Standard Terms & Conditions (QF 907) shall apply to all sales. These are available on request or from our web site.



Relay Monitoring Systems Pty Ltd

6 Anzed Court, Mulgrave, Victoria 3170, AUSTRALIA

Tel: 61 3 9561 0266 Fax: 61 3 9561 0277 Email: rms@rmspl.com.au Web: www.rmspl.com.au