



# 2H34 User Guide

## Multi Stage Frequency Relay

relay monitoring systems Pty Ltd

### **Advanced Protection Devices**



User Guide



Test Manual



Relay Software



μMATRIXwin



# 2H34 User Guide

## About This Manual

---

This User Guide covers all 2H34 relays manufactured from May 2003. Earlier relays do not necessarily incorporate all the features described. Our policy of continuous improvement means that extra features & functionality may have been added.

The 2H34 User Guide is designed as a generic document to describe the common operating parameters for all relays built on this platform. Some relay applications are described but for specific model information the individual "K" number Product / Test manuals should be consulted.

The copyright and other intellectual property rights in this document, and in any model or article produced from it (and including any Registered or unregistered design rights) are the property of Relay Monitoring Systems Pty Ltd. No part of this document shall be reproduced or modified or stored in another form, in any data retrieval system, without the permission of Relay Monitoring Systems Pty Ltd, nor shall any model or article be reproduced from this document without consent from Relay Monitoring Systems Pty Ltd.

While the information and guidance given in this document is believed to be correct, no liability shall be accepted for any loss or damage caused by any error or omission, whether such error or omission is the result of negligence or any other cause. Any and all such liability is disclaimed.

## Contact Us

---

© Relay Monitoring Systems Pty Ltd 2001-2005  
6 Anzed Court • Mulgrave 3170 • AUSTRALIA  
Phone 61 3 9561 0266 • Fax 61 3 9561 0277  
Email [rms@rmspl.com.au](mailto:rms@rmspl.com.au) • Web [www.rmspl.com.au](http://www.rmspl.com.au)

To download a PDF version of this guide:

[http://www.rmspl.com.au/userguide/2h34\\_user\\_guide.pdf](http://www.rmspl.com.au/userguide/2h34_user_guide.pdf)

To download the model specific Test Manual:

<http://www.rmspl.com.au/search.asp>

## How this guide is organised

---

This guide is divided into five parts:

---

### Part 1 Overview

About this Manual

Contents

Test Manual

Mechanical Configuration

Description of Operation

Setting Recommendations

---

### Part 2 Technical Bulletin

---

### Part 3 Software Function

Compatible Software

Factory Default Software

Determining Software UMX

Determining UMX Functionality

User Interface

---

### Part 4 Installation

Handling of Electronic Equipment

Safety

Unpacking

Accessories

Storage & Handling

Recommended Mounting Position

Relay Dimensions & Other Mounting Accessories

Equipment Connections

---

### Part 5 Maintenance

Mechanical Inspection

Test Intervals

Defect Report Form



Visit [www.rmspl.com.au](http://www.rmspl.com.au) for the latest product information.

Due to RMS continuous product improvement policy this information is subject to change without notice. 2H34\_Guide/lss E/04/10/08



## Test Manual

This User Guide covers all 2H34 relay versions & describes the generic features & attributes common across all versions.

Different relay versions are required to cater for varying customer requirements such as auxiliary voltage range, I/O configuration, case style, relay functionality etc.

The product ordering code described in the Technical Bulletin is used to generate a unique version of the relay specification & is called a type number. The type number takes the form 2H34Kxx where the Kxx is the "K" or version number.

Refer to: [www.rmspl.com.au/handbookparta3.pdf](http://www.rmspl.com.au/handbookparta3.pdf)  
for a complete description of the RMS "K" number system.

Each 2H34 version has a specific Test Manual which provides details on the unique attributes of the relay. Each Test Manual includes the following information:

- Test Certificate
- Specific technical variations from the standard model if applicable
- Test & calibration record

A Test Manual is provided with each relay shipped.

A CD & serial comms. cable is supplied with each relay order.

If you require a copy of the Test Manual for an RMS product the following options are available:

- Check the RMS web site at: [www.rmspl.com.au/search.asp](http://www.rmspl.com.au/search.asp)
- RMS CD catalogue select: [List all Product/Test Manuals](#) under [Technical Library](#)
- Contact RMS or a representative & request a hard copy or PDF by email.



## Mechanical Configuration

Great care has been taken to design a rugged, cost effective & flexible mechanical solution for the *MATRIX* range of RMS protection relays. The *MATRIX* range provides a compact draw out case solution with M4 screw terminals:

- 2M28 Size 2 with 28 terminals
- 4M28 Size 4 with 28 terminals
- 4M56 Size 4 with 56 terminals

Complete details & attributes for the M (MATRIX) cases & accessories may be found at:

<http://www.rmspl.com.au/mseries.htm>

The 2H34 is configured in a 4M56 case & the following photographs depict the general mechanical configuration. It should be noted that re-usable screw rivets are used to bind the draw out relay module. A 1/16" hex key is required for disassembly.



Image of generic inner relay module after removal from outer case.

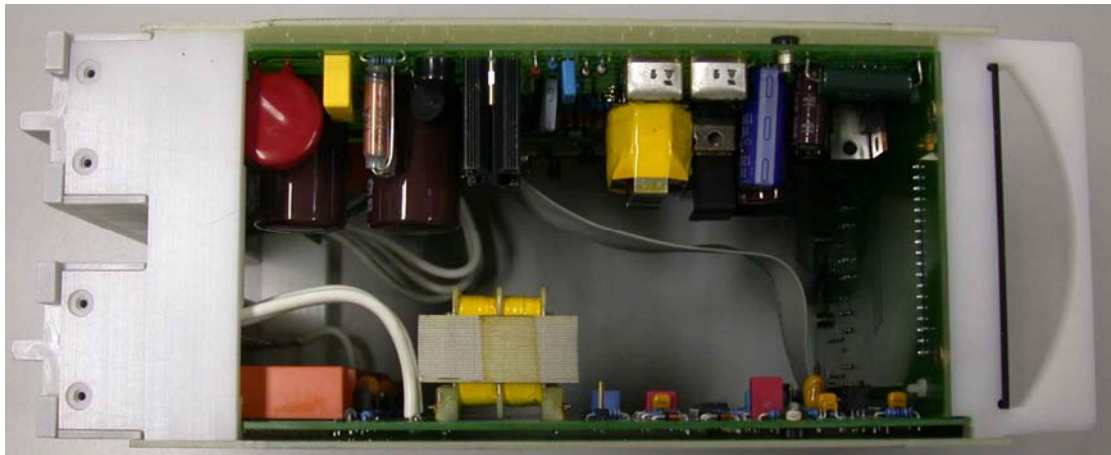
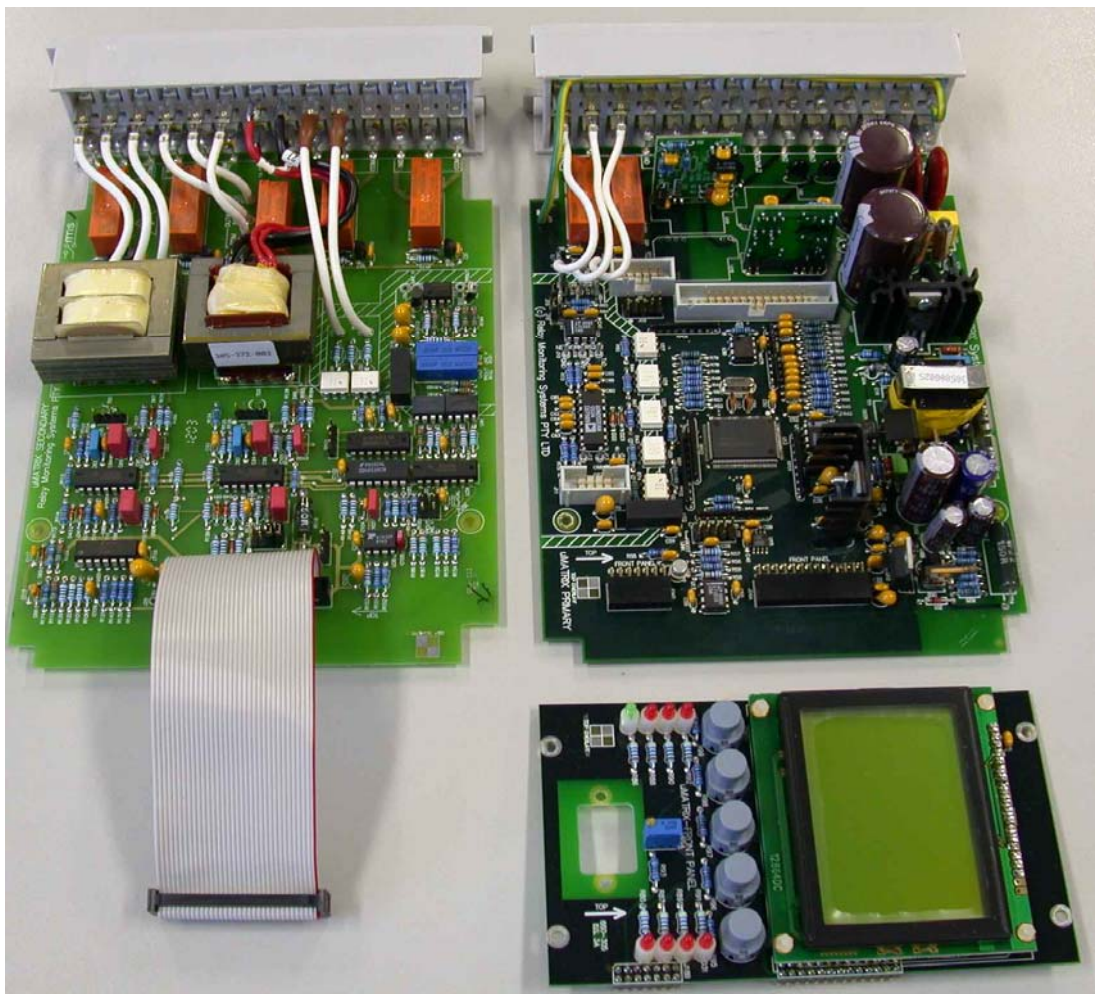

Image of the relay module showing the switch mode power supply components at the top.



Typical set of three PCB's. Note the terminal blocks fitted to the top two assemblies.



## Description of Operation

Reduction in system frequency is an early indicator of impending system voltage collapse. This can lead to plant & equipment damage if not taken off line or the frequency / voltage level restored. The 2H34 relay can be used to provide four stages of load shedding as the frequency progressively falls through the four independent setting stages. A rate of frequency change ROCOF element ( $dF/dt$ ), can also be established for each stage for the detection of very fast frequency loss due to disconnection from the mains grid.

The 2H34 Series relay is a frequency monitoring relay with four stages of adjustable frequency pick up & drop out points. Each frequency set point can be set for under or over frequency operation & has an independent time delay driving an output relay. An undervoltage lockout is used to disable the four frequency outputs when the voltage falls below a preset level.

A single status input is used to enable the four frequency sensing stages.

A second status input is used to reset the front panel latched LED trip indicators.

Each of the four setting stages has a rate of change of frequency (ROCOF) element with an independent time delay. The  $dF/dt$  element is available to operate as an AND or an OR logic function with the frequency element driving a common output contact per stage.

A separate Under Voltage & Over Voltage stage are provided for alarm functions.

The 2H34 relay is built on the Micro MATRIX digital platform. The standard Micro MATRIX human machine interface (HMI) is combined with fully solid state voltage sensing & measuring circuitry to provide high accuracy, simple set up & flexible operation. Self-monitoring is carried out by hardware & software watchdogs. A CPU software watchdog records abnormal events & performs automatic periodic checks. High speed, high contact rating output relays are used.

The input transformer, output relays & opto isolated status input form the essential barriers against high voltage line transients while a switchmode auxiliary supply provides a wide operating range.

An RS232 programming port is provided for ease of establishing relay settings using a PC &  $\mu$ MATRIXwin which is available free of charge.



Visit [www.rmspl.com.au](http://www.rmspl.com.au) for the latest product information.

Due to RMS continuous product improvement policy this information is subject to change without notice. 2H34\_Guide/lss E/04/10/08



# Setting Recommendations

The relay is supplied with the following default settings:

	STAGE 1	STAGE 2	STAGE 3	STAGE 4
Frequency detection function:	O/F	U/F	U/F	U/F
Frequency set point:	52.00Hz	49.00Hz	48.00Hz	47.00Hz
Hysteresis:	0.10Hz	0.10Hz	0.10Hz	0.10Hz
Time delay:	10.00s	5.00s	5.00s	2.00s
Reset delay:	0.5s	0.5s	0.5s	0.5s
dF/dt set point:	0.80Hz/s	1.00Hz/s	1.2Hz/s	1.40Hz/s
Time delay:	0.30s	0.20s	0.10s	0.04s
<b>UNDERVOLTAGE LOCKOUT STAGE</b>				
Set point:	70.0V			
Hysteresis:	1.0V			
Alarm output:	PU			
<b>UNDERVOLTAGE ALARM STAGE</b>				
Set point:	100.0V			
Hysteresis:	1.0V			
<b>OVERVOLTAGE ALARM STAGE</b>				
Set point:	120.0V			
Hysteresis:	1.0V			
<b>dF/dt GLOBAL SETTINGS</b>				
Function:	Disabled			
Sample cycles:	3 cycles			
dF/dt Maximum limit:	3.0Hz			
<b>STATUS INPUT</b>				
Relay enable:	Apply V			
Remote flag reset:	Apply V			
<b>RS232 FRONT PROGRAMMING PORT</b>				
Baud rate:	19,200 Bd			
<b>REAR NETWORK PORT</b>				
Baud rate:	19,200 Bd			
Parity:	None			
Data bits:	8			
Stop bits:	1			
Modbus address:	96			



Visit [www.rmspl.com.au](http://www.rmspl.com.au) for the latest product information.

Due to RMS continuous product improvement policy this information is subject to change without notice. 2H34\_Guide/lss E/04/10/08





# Setting Recommendations

## Frequency Step Set Points

Each of the four frequency stage step set points are independently adjustable and are accurate to  $\pm 0.03\text{Hz}$  with a measurement resolution of  $0.01\text{Hz}$  at  $50\text{Hz}$ . This means that the hysteresis can be set to a very small value; as low as  $0.05\text{Hz}$ . This allows the frequency pick up set points to be adjusted very close to the nominal system frequency ( $50$  or  $60\text{Hz}$ ). Set points to within  $0.1\text{Hz}$  of the nominal system frequency will be stable although the actual setting used will depend on system conditions and stability.

## Frequency Time Delays

For under frequency load shedding schemes the greater the frequency excursion the shorter the time delay setting.

## Frequency Hysteresis

In general the closer the frequency set point is to the nominal system frequency, the lower the hysteresis setting should be. This is to ensure that momentary small frequency deviations which start the timer element are reset when the frequency recovers.

## Reset Time

Where small hysteresis settings are used, consideration should be given to fast transient noise hits which may continuously reset the time delay element and not allow the stage to time out. The reset time is essentially a “hysteresis” on the delay timer. Once a timer is started, a momentary recovery will cause the timer to pause for the duration of the reset time. If the start signal occurs again before the reset time expires the timer will continue timing from the previous count.

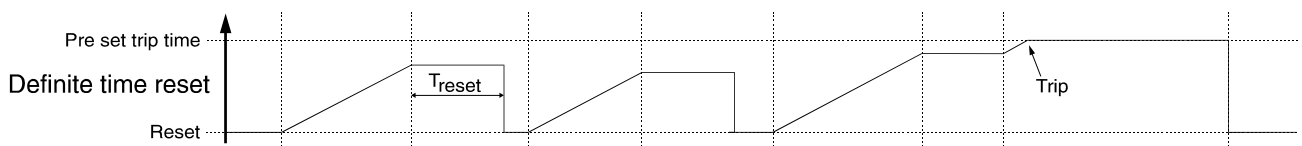

Visit [www.rmspl.com.au](http://www.rmspl.com.au) for the latest product information.

Due to RMS continuous product improvement policy this information is subject to change without notice. 2H34\_Guide/lss E/04/10/08



# Setting Recommendations

## **dF/dt FUNCTION**

Rate of change of frequency known as ROCOF or dF/dt is a useful parameter for the fast detection of events such as disconnection of a generator from the grid.

Under such conditions it is unlikely that an under frequency element will operate fast enough to protect the power system before the frequency & voltage has dropped below acceptable limits.

Operation of the dF/dt function is governed by a number of global settings which effect the four dF/dt stages.

## **dF/dt SAMPLE TIME**

The dF/dt measurements are based on the difference between successive frequency readings recorded on each cycle of the AC signal being monitored. A minimum of two (2) frequency readings over 2 cycles are required to achieve adequate stability, resolution & accuracy.

dF/dt measurements based on a small number of samples is required for fast response but is not suitable for detecting slow dF/dt rates below 0.70Hz/s.

dF/dt measurement based on a larger number of samples is required to detect very slow dF/dt rates but is consequently slower to respond.

A global dF/dt sample time setting is provided to optimize the 2H34 operating performance to the dF/dt pick up & time delay setting required. The default of 3 cycles is suitable for all but the slowest dF/dt settings. 2 cycle sample times should only be used where very fast operation is required as accuracy is compromised.

## **dF/dt REJECTION**

A global function is provided to reject dF/dt readings above a user defined setting. This feature is used to reject spurious readings due to noise & transients to ensure stability & improve security particularly when using short delay times.

Setting range: 0.2 to 20Hz/s in 0.1Hz/s steps

The dF/dt rejection setting should be chosen to be approximately twice the maximum dF/dt P/U setting.



Visit [www.rmspl.com.au](http://www.rmspl.com.au) for the latest product information.

Due to RMS continuous product improvement policy this information is subject to change without notice. 2H34\_Guide/lss E/04/10/08



# Setting Recommendations

## dF/dt TIME DELAY SETTING

The 2H34 allows for a separate time range for each of the four dF/dt stage set points.

Setting range: 0.00 to 100s in 0.02s steps.

Timing error: <20ms + 0.1% of the time delay setting

The dF/dt element operate time is dependant on the sample time setting which determines the dF/dt measurement time shown in Table 1.

The actual operate time for each stage is the sum of the global dF/dt measurement time + the dF/dt stage time delay setting +/- timing error.

A minimum dF/dt time delay setting of 40ms is recommended.

## dF/dt SETTING CRITERIA

Table 1

Sample time (Cycles)	2	3	4	5
Maximum setting (Hz/s)	9	7	6	5
Minimum setting (Hz/s)	0.70	0.50	0.20	0.13
Minimum time delay setting	40ms	60ms	80ms	100ms
dF/dt Measurement time	70ms	100ms	150ms	200ms
Hysteresis (Hz/s)	0.24	0.12	0.07	0.05
Accuracy at 50Hz (Hz/s)	+/-0.2	+/-0.1	+/-0.07	+/-0.05
Timing accuracy	+/-30ms	+/-40ms	+/-50ms	+/-60ms



Visit [www.rmspl.com.au](http://www.rmspl.com.au) for the latest product information.

Due to RMS continuous product improvement policy this information is subject to change without notice. 2H34\_Guide/lss E/04/10/08



## Technical Bulletin

The detailed technical attributes, functional description & performance specifications for the 2H34 are described in the attached Technical Bulletin. For the most up to date version go to:

[www.rmspl.com.au/handbook/2h34.htm](http://www.rmspl.com.au/handbook/2h34.htm)

For any specific attributes of a particular version refer to the Test Manual for that type (K) number.

The order of precedence for technical information is as follows:

- Test Manual
- Technical Bulletin
- User Guide

## Features

- Large back lit display panel
- High resolution frequency & voltage display readout
- Four independent frequency stages
- Independent time delay per frequency stage
- 41 to 59Hz PU setting range
- 63.5/110V AC nominal inputs
- Four independent rate of change dF/dt detection stages
- Independent definite time delay per dF/dt stage
- Adjustable dF/dt sample measurement time to optimize accuracy & response time
- Timing & trip indication LED's
- Separate overvoltage & undervoltage alarm stages with independent output relays
- Undervoltage blocking function
- Relay enable input
- CPU watchdog
- Wide auxiliary supply range with fail alarm contact

### COMMUNICATION

- RS232 PC programming port
- Non platform specific PC programming software
- Optically isolated communication ports
- MODBUS RTU compatible protocol on RS485 or RS232 network port
- Size 4 draw out case

## Application

Reduction in system frequency is an early indicator of impending system voltage collapse. This can lead to plant & equipment damage if not taken off line or the frequency / voltage level restored. The 2H34 relay can be used to provide four stages of load shedding as the frequency progressively falls through the four independent setting stages. A rate of frequency change ROCOF element (dF/dt), can also be established for each stage for the detection of very fast frequency loss due to disconnection from the mains grid.

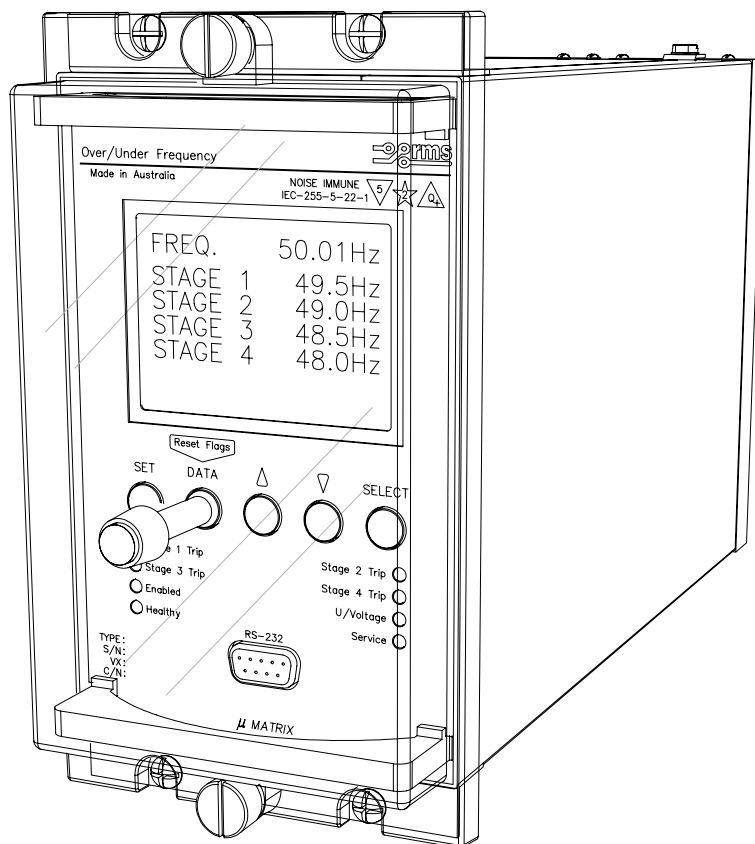

2H34 in size 4 rack mount case

## Operation

Made in Australia

The 2H34 Series relay is a frequency monitoring relay with four stages of adjustable frequency pick up & drop out points. Each frequency set point can be set for under or over frequency operation & has an independent time delay driving an output relay. An undervoltage lockout is used to disable the four frequency sensing stages when the voltage falls below a preset level.

A single status input is used to enable the four frequency sensing stages.  
A second status input is used to reset the front panel latched LED trip indicators.

Each of the four setting stages has a rate of change of frequency (ROCOF) element with an independent time delay. The dF/dt element is available to operate as an AND or an OR logic function with the frequency element driving a common output contact per stage.

A separate Under Voltage & Over Voltage stage are provided for alarm functions.

The 2H34 relay is built on the Micro MATRIX digital platform. The standard Micro MATRIX human machine interface (HMI) is combined with fully solid state voltage sensing & measuring circuitry to provide high accuracy, simple set up & flexible operation. Self-monitoring is carried out by hardware & software watchdogs. A CPU software watchdog records abnormal events & performs automatic periodic checks. High speed, high contact rating output relays are used.

The input transformer, output relays & opto isolated status input form the essential barriers against high voltage line transients while a switchmode auxiliary supply provides a wide operating range.

An RS232 programming port is provided for ease of establishing relay settings using a PC &  $\mu$ MATRIXwin which is available free of charge.

### FREQUENCY STEP SET POINTS

Inputs: Single pole 63.5/110V AC nominal  
 Setting stages: 4 independent stages  
 Operating range: 40 to 60 Hz  
 Setting range: 41 to 59Hz in 0.05Hz steps  
 Measurement resolution: 0.01Hz at 50Hz  
 Accuracy: +/-0.03Hz (70 to 121V) at 50Hz  
 Hysteresis: 0.05 to 0.5Hz in 0.05Hz steps  
 Frequency measuring time: 20ms (Add to time delay setting)  
 Over frequency function: PU at set point  
 DO at set point – hysteresis +/-0.03Hz  
 Under frequency function: PU at set point  
 DO at set point + hysteresis +/-0.03Hz

### FREQUENCY STEP TIME DELAY SETTING

The 2H34 allows for a separate time range for each of the four frequency stage set points.  
 Setting range: 0.1 to 100s in 0.05s steps.  
 Minimum operate time: 0.1s typical  
 Timing error: <20ms + 0.1% of time delay setting

### RESET TIME DELAY

Electronic reset time: 0.0 to 5s in 0.1s steps  
 Accuracy: <60ms + 0.1% of setting  
 When the frequency pick up & drop out points are set very close together it is advisable to set a longer reset delay to avoid timer resetting due to transient frequency fluctuations.

### UNDER VOLTAGE LOCKOUT

An Under Voltage lockout feature is used to block all output stages in the event of voltage loss caused by a failed VT or fuse.  
 Setting range: 20 to 100V in 0.1V steps  
 Accuracy: +/-250mV or +/-0.5% of setting  
 Fixed time delay: 370ms approx.  
 Hysteresis: 0.2 to 5V in 0.1V steps

### UNDER VOLTAGE PROTECTION

An Under Voltage protection stage is available to monitor & trip if the pre set voltage level is reached.  
 Setting range: 20 to 110V in 0.1V steps  
 Accuracy: +/-250mV or +/-0.5% of setting  
 Fixed time delay: 370ms approx.  
 Hysteresis: 0.2 to 5V in 0.1V steps

### OVER VOLTAGE PROTECTION

An Under Voltage protection stage is available to monitor & trip if the pre set voltage level is reached.  
 Setting range: 110 to 140V in 0.1V steps  
 Accuracy: +/-0.5% of setting  
 Fixed time delay: 370ms approx.  
 Hysteresis: 0.2 to 5V in 0.1V steps

### OUTPUT STAGES

All contacts are self reset.

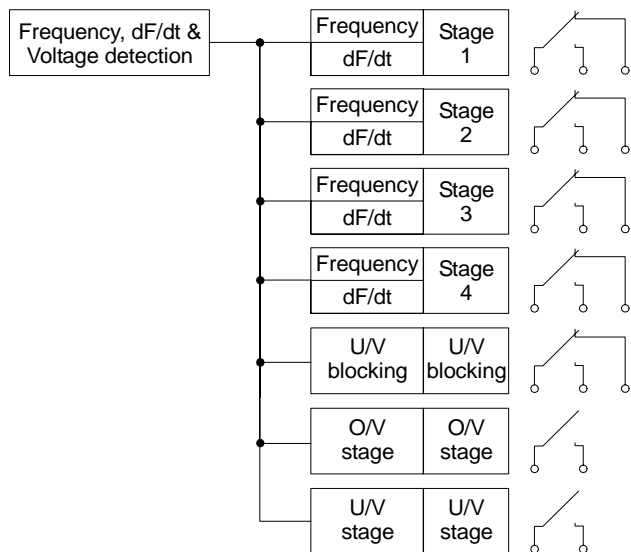

### AUXILIARY SUPPLY

20-70V DC switchmode supply or  
 40-275V AC / 40-300V DC switchmode supply

#### Inputs:

A high efficiency switchmode power supply is incorporated which provides a low burden to the auxiliary supply.

### BURDENS

Auxiliary supply: At 110V DC nominal supply  
 During timing: < 7 watts  
 With output relays energized: < 10 watts  
 Sensing circuits: < 1VA per phase all setting

### RELAY FAIL ALARM

A C/O alarm contact is maintained in the energized state when all of the following conditions are met:

- The auxiliary supply is applied
- The internal 24V DC rail is within acceptable limits
- The CPU hardware watchdog maintains a pulsing output

A CPU software watchdog records "suspect" events to an assert register and if necessary performs a soft restart.

### RELAY ENABLE STATUS INPUT

The status input on the 2H34 is used to enable the four frequency monitoring stages of the relay. The relay must be "enabled" in order for the time delay stages to operate. A front panel LED is illuminated red when the relay is disabled.

### STATUS INPUT FUNCTION

The status input function is factory set to enable on the application of a control voltage. It is also possible for the status input to operate on the removal of a control voltage by simply changing a software flag in the PC setup program.

### OUTPUT CONTACT RATINGS

#### Make & carry

30A AC or DC (Limits L/R=40ms & 300V max.) for 0.2s  
 20A AC or DC (Limits L/R=40ms & 300V max.) for 0.5s  
 5A AC or DC continuously

#### Break (Limits 5A & 300V max.)

1,250VA AC resistive  
 250VA at 0.4PF AC inductive  
 75W DC resistive  
 30W DC inductive L/R = 40ms  
 50W DC inductive L/R = 10ms

#### Minimum recommended load

0.5W, 10mA or 5V minimum.

### AMBIENT OPERATING TEMPERATURE RANGE

-5 to 55 degrees C.

### INSULATION WITHSTAND

IEC60255-5 2KV RMS & 1.2/50 5KV impulse between:

- ♦ all input terminals & frame
- ♦ all output terminals & frame
- ♦ all input & output terminals
- ♦ each input group
- ♦ each output group

### HIGH FREQUENCY DISTURBANCE

IEC60255-22-1 2.5KV 1MHz common mode  
 1.0KV 1MHz differential mode

### ELECTROSTATIC DISCHARGE

EN61000-4-2:1995 8KV Level 3

### FAST TRANSIENT DISTURBANCE

EN61000-4-4:1995 4KV Level 4

### CASE

Size 4 draw out  
 56 M4 screw terminals  
 Flush panel mount or 4U high 1/4 width 19 inch rack mount  
 IP51 rating

### ACCESSORIES SUPPLIED WITH EACH RELAY

1 x M4 self threading mounting screw kit P/N 290-406-151  
 2 x M4 terminal screw kit (28 per kit) P/N 290-407-153

### dF/dt FUNCTION

Rate of change of frequency known as ROCOF or dF/dt is a useful parameter for the fast detection of events such as disconnection of a generator from the grid.

Under such conditions it is unlikely that an under frequency element will operate fast enough to protect the power system before the frequency & voltage has dropped below acceptable limits.

### dF/dt SAMPLING ENGINES

Performance of the dF/dt elements is dependant on the sampling time used to calculate & average the dF/dt reading.

dF/dt measurements are based on the difference between successive frequency readings recorded on each cycle of the AC signal being monitored.

dF/dt measurements based on 2 samples is required for fast response but is not suitable for detecting low dF/dt rates.

dF/dt measurements based on 5 samples is required to detect very slow dF/dt rates but is consequently slower to respond & is not suitable for detecting high dF/dt rates.

To allow dF/dt setting flexibility while remaining within the constraints described in Table 1, two dF/dt sampling engines (A & B) are provided:

- dF/dt activation: Set to ON or OFF
- Sample time A: 2 to 5 cycles in 1 cycle steps
- dF/dt rejection A: 0.2 to 18Hz/s in 0.1Hz/s steps
- Sample time B: 2 to 5 cycles in 1 cycle steps
- dF/dt rejection B: 0.2 to 18Hz/s in 0.1Hz/s steps

### dF/dt REJECTION FUNCTION

A dF/dt rejection setting is provided to reject dF/dt readings above a user defined setting. This feature is used to reject spurious readings due to noise & transients to ensure stability & improve security particularly when using short delay times. When selecting a dF/dt rejection setting, consideration should be given to the maximum dF/dt rate expected on the system plus 1Hz/s. As a separate dF/dt rejection setting is available for each dF/dt engine, these may be set to approximately twice the maximum dF/dt P/U setting used for that engine.

### dF/dt SET POINTS

Four independent dF/dt elements are provided. When this function is activated the dF/dt pick up is used to initiate an independent dF/dt timer.

- Setting stages: 4 independent stages
- Setting range: 0.13 to 9.0Hz/s in 0.1Hz/s steps
- dF/dt function: PU at set point  
DO at set point – hysteresis
- dF/dt engine: Select dF/dt sampling engine A or B

### dF/dt SETTING CRITERIA

Sample time (Cycles)	2	3	4	5
Maximum setting (Hz/s)	9	7	6	5
Minimum setting (Hz/s)	0.70	0.50	0.20	0.13
Minimum time delay setting	40ms	60ms	80ms	100ms
dF/dt Measurement time	70ms	100ms	150ms	200ms
Hysteresis (Hz/s)	0.24	0.12	0.07	0.05
Accuracy at 50Hz (Hz/s)	+/-0.2	+/-0.1	+/-0.07	+/-0.05
Timing accuracy	+/-30ms	+/-40ms	+/-50ms	+/-60ms

Table 1

## dF/dt Function (ROCOF)

### dF/dt MINIMUM & MAXIMUM SETTING

The dF/dt setting range is dependant on the sample time setting as shown in Table 1. Outside the specified setting range the stated accuracy is not met.

### dF/dt TIME DELAY SETTING

The 2H34 allows for a separate time range for each of the four dF/dt stage set points.

- Setting range: 0.00 to 100s in 0.02s steps.
- Timing accuracy: Refer table 1.

The dF/dt element operate time is dependant on the sample time setting which determines the dF/dt measurement time shown in Table 1.

The actual operate time for each stage is the sum of the dF/dt measurement time + the dF/dt stage time delay setting +/- timing error.

A minimum dF/dt time delay setting equal to the sample time setting is recommended as per Table 1.

### dF/dt FUNCTION LOGIC OPTIONS

Two global logic options are available:

The OR logic function requires either the frequency step element OR the dF/dt element to time out for the stage output relay to operate.

The AND logic function requires both the frequency step element AND the dF/dt element to time out for the stage output relay to operate.

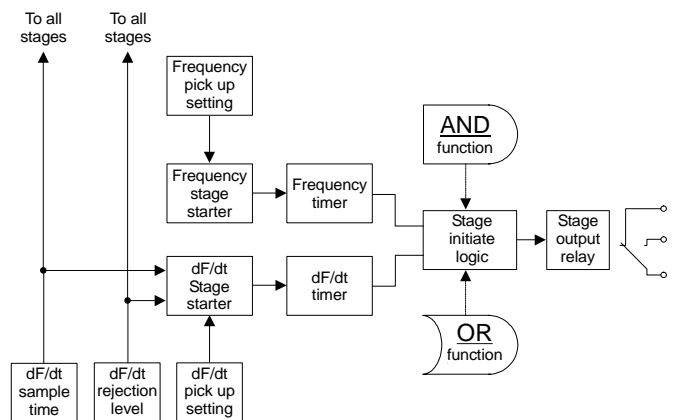

### dF/dt ACCURACY

A typical dF/dt measurement sweep is depicted below using a sample time of 4 cycles which provides high measurement accuracy but & moderate response time.

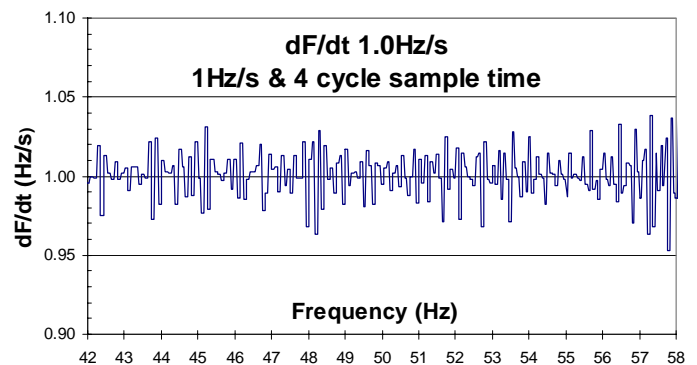

While random noise hits may cause spikes beyond the maximum error quoted these will not be of sufficient duration to cause a trip event due to the time delay setting & dF/dt rejection function.

Where very fast operate times are required for dF/dt rates above 0.70Hz/s, shorter sample times must be used at the expense of measurement accuracy. The dF/dt measurement accuracy for each sample time setting is shown in Table 1.

### PC TO $\mu$ MATRIX SERIAL CABLE

One cable supplied with each order.  
P/N 997-000-042

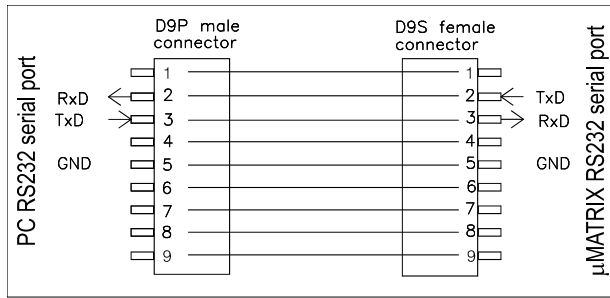

# Communications

## COMMUNICATION PORTS

Two (2) communications ports are available.

### Programming port

The programming port is accessible from the front panel of the relay via an RS232 physical link & PC configuration program supplied with the relay. The  $\mu$ MATRIXwin configuration program is designed to operate with all relays from the  $\mu$ MATRIX range & all firmware versions.

### Network port

The network port is intended for applications where permanent connection to a master control system is required. An optically isolated RS232 or RS485 physical layer is provided for this function.

The RS485 connection is intended for applications where multiple  $\mu$ MATRIX relays are to be connected on a common communications bus.

The RS232 connection is intended for interface to an RS232 to optic fiber converter in environments subject to extreme electrical interference.

The network port may be used for a permanent link to a modem, remote PC, data concentrator or SCADA system. The standard communications protocol is MODBUS RTU.

### Changing the Network port from RS485 to RS232

$\mu$ MATRIX relays are shipped with the rear network port terminals configured as RS485. This configuration may be changed in the field to RS232 if required by withdrawing the relay module from the case & changing the three configuration links as depicted.

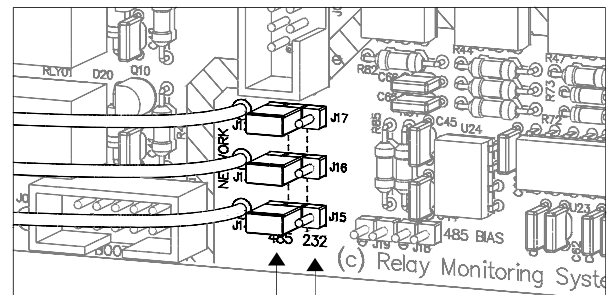

RS485 Port Header Position

RS232 Port Header Position

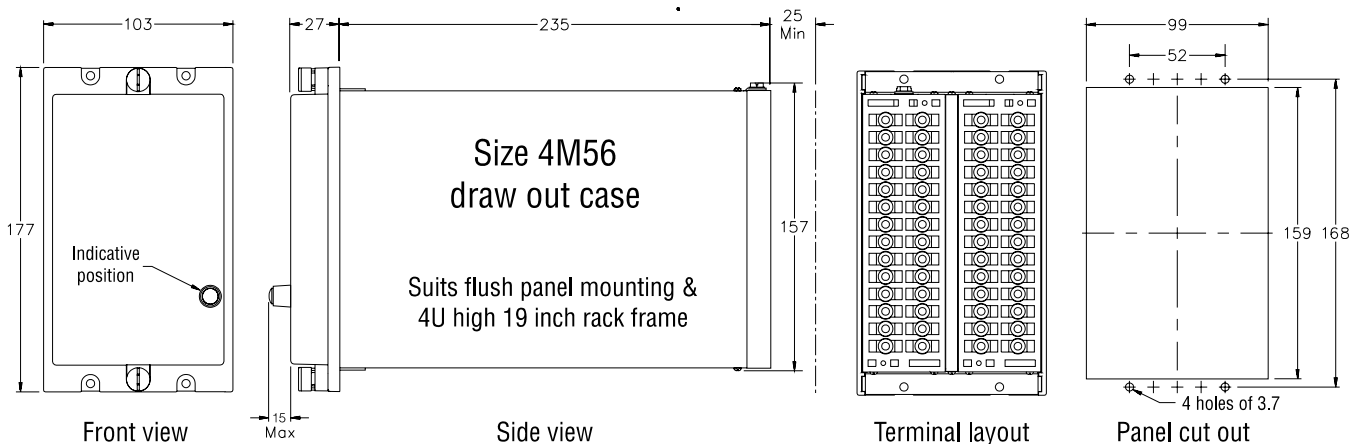



# Ordering Information

Generate the required ordering code as follows: e.g. 2H34 BBB

2H34 1 2 3

## 1 AUXILIARY SUPPLY RANGE

- A 20-70V DC
- B 40-275V AC / 300V DC

## 2 RELAY INITIATE INPUT

Opto-isolated input

- A 24-80V AC/DC
- B 75-150V AC/DC
- C 150-300V AC/DC

## 3 REMOTE FLAG RESET INPUT

Opto-isolated input

- A 24-80V AC/DC
- B 75-150V AC/DC
- C 150-300V AC/DC

## ! REQUEST DEFAULT APPLICATION SOFTWARE

- A UMX2H34-A Frequency OR dF/dt output logic function
- B UMX2H34-B Frequency AND dF/dt output logic function

All current UMX software applications may be downloaded from:

[www.rmspl.com.au/umatrix](http://www.rmspl.com.au/umatrix)

These may then be loaded into the relay using uMATRIXwin.

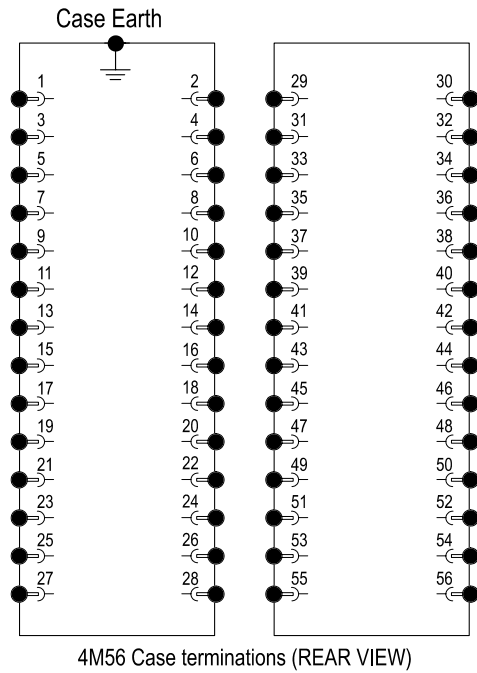

\*Note: The status inputs & some relay outputs are assigned by the software (UMX) loaded on the relay.

Shown here are the standard terminal assignments of the A UMX. Other UMX versions may differ. Consult the UMX manuals for specific I/O assignments.

FRONT PANEL PC PROGRAMMING PORT

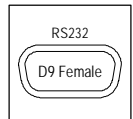

One DE09 straight through male to female 2 metre connection cable supplied with each order of relays (P/N 997-000-042B)

SCADA COMMUNICATIONS PORT (Use one only)

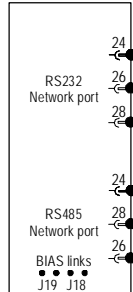

Dedicated supervisory connection

RS485 Shielded twisted pair cable (Up to 1Km)

To other uMATRIX relays (Up to 32 units)  
Fit external terminating resistor to end of BUS relay only  
Fit internal BIAS jumper links for single relay connection only

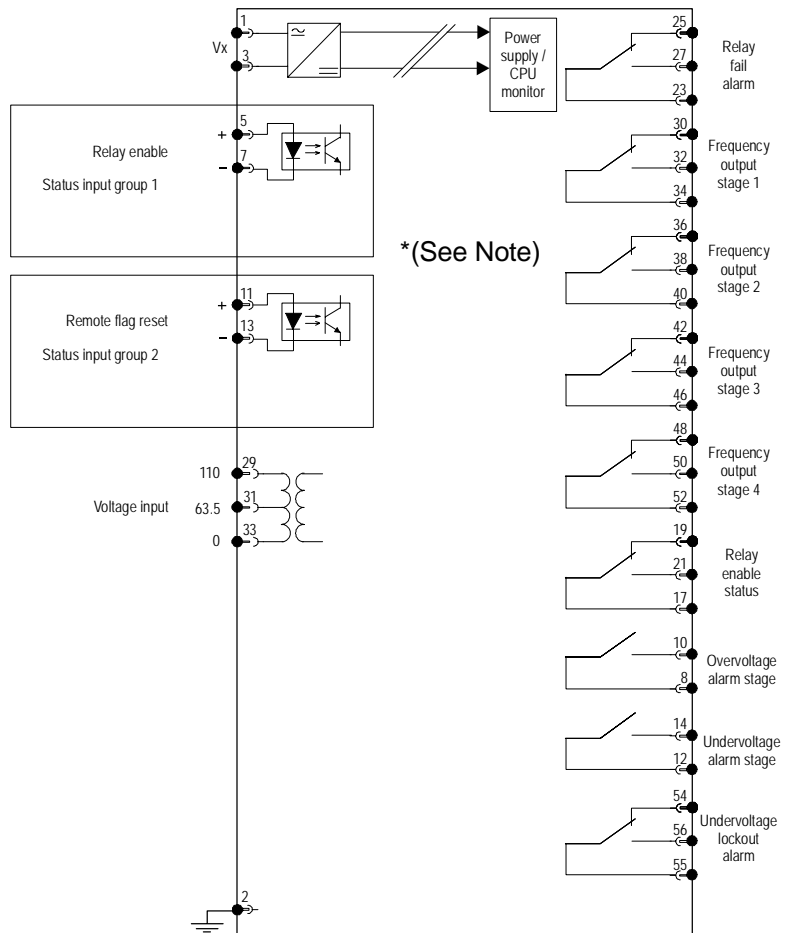

2H34 wiring diagram - Relay shown in de-energised condition



## Software Function

### **Compatible Software UMX**

The 2H34 relay has a number of software programs called UMX available, which can be installed by the user. Each UMX provides a different functional configuration to suit specific applications. They must be however, compatible with the relay hardware.

A copy of the UMX Hardware / Software Compatibility Register is attached.

Download the most up to date UMX Hardware / Software Compatibility Register from the RMS website:

<http://www.rmspl.com.au/digital/compatibility.pdf>

### **Factory Default Software**

The 2H34 relay is ordered with a customer specified default UMX so that it is ready for operation when received. To achieve this, an ordering code may be sought at time of quotation and specified on your order.



## Determining Software UMX

Determining which UMX is loaded onto a MATRIX relay may be done in three ways:

1. New relays received from the factory have a label located on the side of the draw out module. This label is printed with information specific to the relay and includes the UMX type that was loaded during production.
2. Press the DATA and SET page buttons on the relay simultaneously to bring up the DIAGNOSTICS page.

Now press SELECT to view the versions page and you will see:

**\*\* VERSION PAGE \*\***

BIOS Version: Vxx.xx	The version of the low level BIOS code loaded by the factory.
S/W Version: Vxx.xx	The version of the software UMX.
CBD: RMS Default	The .ump parameters file saved to the relay from $\mu$ MATRIXwin.
Model: xxxxxS	The xxxxx is the relay hardware code. The "S" is the UMX code.
S/N: xxxxxx.xx	The production tracking serial number also found on the front label.
H/W Config: xx	This number is related to the PCB loading and is auto detected.

3. Connect to the relay through the front panel RS232 configuration port using  $\mu$ MATRIXwin and a PC. The UMX code & version is displayed at the bottom of the centre panel.

## Determining UMX Functionality

Now that you have determined the UMX loaded in the relay you need to obtain the Software Functional Description Document which relates to it. It may be obtained from our web site as follows:

Document name is: UMX2H34s.pdf using the "s" code from the version page above.

The location is: [www.rmspl.com.au/ptmanual/umx2h34x.pdf](http://www.rmspl.com.au/ptmanual/umx2h34x.pdf)

## User Interface

Refer to the  $\mu$ MATRIX Users Guide for detailed instructions on the operation of the user interface.

To download a PDF version of the guide:

[www.rmspl.com.au/digital/umatrixinfo.pdf](http://www.rmspl.com.au/digital/umatrixinfo.pdf)

To download further  $\mu$ MATRIX software & documentation:

[www.rmspl.com.au/umatrix.htm](http://www.rmspl.com.au/umatrix.htm)



Visit [www.rmspl.com.au](http://www.rmspl.com.au) for the latest product information.

Due to RMS continuous product improvement policy this information is subject to change without notice. 2H34\_Guide/lss E/04/10/08

## Installation

### Handling of Electronic Equipment

A person's normal movements can easily generate electrostatic potentials of several thousand volts. Discharge of these voltages into semiconductor devices when handling electronic circuits can cause serious damage, which often may not be immediately apparent but the reliability of the circuit will have been reduced.

The electronic circuits of Relay Monitoring Systems Pty Ltd products are immune to the relevant levels of electrostatic discharge when housed in the case. Do not expose them to the risk of damage by withdrawing modules unnecessarily.

Each module incorporates the highest practicable protection for its semiconductor devices. However, if it becomes necessary to withdraw a module, the following precautions should be taken to preserve the high reliability and long life for which the equipment has been designed and manufactured.

1. Before removing a module, ensure that you are at the same electrostatic potential as the equipment by touching the case.
2. Handle the module by its front-plate, frame, or edges of the printed circuit board.
3. Avoid touching the electronic components, printed circuit track or connectors.
4. Do not pass the module to any person without first ensuring that you are both at the same electrostatic potential. Shaking hands achieves equipotential.
5. Place the module on an antistatic surface, or on a conducting surface which is at the same potential as yourself.
6. Store or transport the module in a conductive bag.

If you are making measurements on the internal electronic circuitry of an equipment in service, it is preferable that you are earthed to the case with a conductive wrist strap.

Wrist straps should have a resistance to ground between 500k – 10M ohms. If a wrist strap is not available, you should maintain regular contact with the case to prevent the build up of static.

Instrumentation which may be used for making measurements should be earthed to the case whenever possible.



## Safety Section

**This Safety Section should be read before commencing any work on the equipment.**

The information in the Safety Section of the product documentation is intended to ensure that products are properly installed and handled in order to maintain them in a safe condition. It is assumed that everyone who will be associated with the equipment will be familiar with the contents of the Safety Section.

### Explanation of Symbols & Labels

The meaning of symbols and labels which may be used on the equipment or in the product documentation, is given below.

**Caution:** refer to product information



**Caution:** risk of electric shock



### Functional earth terminal

**Note:** this symbol may also be used for a protective/safety earth terminal if that terminal is part of a terminal block or sub-assembly eg. power supply.

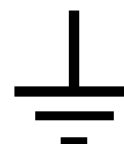



## Unpacking

Upon receipt inspect the outer shipping carton or pallet for obvious damage.

Remove the individually packaged relays and inspect the cartons for obvious damage.

To prevent the possible ingress of dirt the carton should not be opened until the relay is to be used. Refer to the following images for unpacking the relay:



Outer packing carton showing shipping documentation pouch.  
Address label on top of carton.



Inner packing carton showing front label detailing the customer name, order number, relay part number & description, the relay job number & packing date. (Size 2 inner packing carton depicted)



Visit [www.rmspl.com.au](http://www.rmspl.com.au) for the latest product information.

Due to RMS continuous product improvement policy this information is subject to change without notice. User\_Guide-4/lss E/25/08/08

## Unpacking (Continued)



Inner packing carton with lid open showing protective foam insert.

CD depicted supplied with digital relay models or upon request at time of order.



Inner packing carton with protective foam insert removed showing relay location.



Where mechanical flags are fitted the yellow transit wedge must be removed before operation using a gentle twisting action. The wedge should be stored with the original packaging material.

**Relay Module Side Label Depicting Product Details**



**Relay Module Side Label Depicting Wiring Diagram (6R MATRIX relays only)**

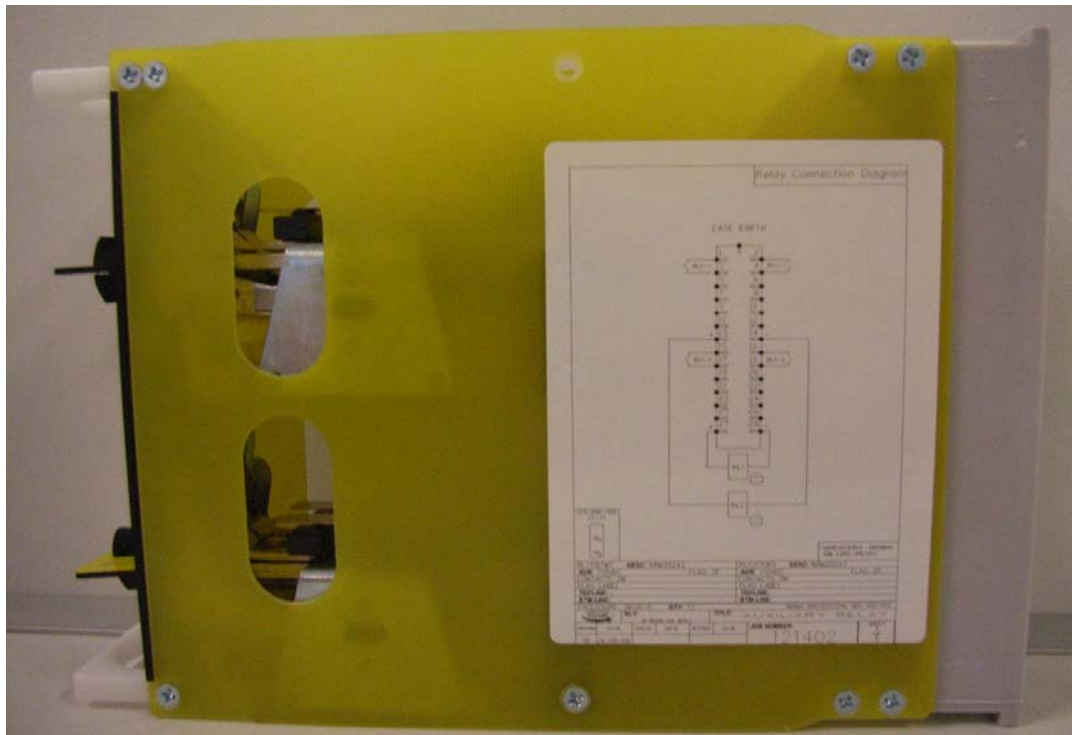



## Accessories Supplied With Each Relay



Self threading M4 mounting screws



M4 terminal screws with captured lock washers

## Storage & Handling

If damage has been sustained a claim should immediately be made against the carrier, also inform Relay Monitoring Systems Pty Ltd and the nearest RMS agent

When not required for immediate use, the relay should be returned to its original carton and stored in a clean, dry place.

Relays which have been removed from their cases should not be left in situations where they are exposed to dust or damp. This particularly applies to installations which are being carried out at the same time as constructional work.

If relays are not installed immediately upon receipt they should be stored in a place free from dust and moisture in their original cartons.

Dust which collects on a carton may, on subsequent unpacking, find its way into the relay; in damp conditions the carton and packing may become impregnated with moisture and the de-humidifying agent will lose its efficiency.



### **Equipment Operating Conditions**

The equipment should be operated within the specified electrical and environmental limits.

Protective relays, although generally of robust construction, require careful treatment prior to installation and a wise selection of site. By observing a few simple rules the possibility of premature failure is eliminated and a high degree of performance can be expected.

Care must be taken when unpacking and installing the relays so that none of the parts are damaged or their settings altered and must at all times be handled by skilled persons only.

Relays should be examined for any wedges, clamps, or rubber bands necessary to secure moving parts to prevent damage during transit and these should be removed after installation and before commissioning.

The relay should be mounted on the circuit breaker or panel to allow the operator the best access to the relay functions.

### **Relay Dimensions & Other Mounting Accessories**

Refer drawing in Technical Bulletin. Relevant Auto Cad files & details on other accessories such as 19 inch sub rack frames, semi projection mount kits & stud terminal kits may be down loaded from:

<http://www.rmspl.com.au/mseries.htm>



Visit [www.rmspl.com.au](http://www.rmspl.com.au) for the latest product information.

Due to RMS continuous product improvement policy this information is subject to change without notice. User\_Guide-4/lss E/25/08/08

## Equipment Connections

Personnel undertaking installation, commissioning or servicing work on this equipment should be aware of the correct working procedures to ensure safety. The product documentation should be consulted before installing, commissioning or servicing the equipment.

Terminals exposed during installation, commissioning and maintenance may present hazardous voltage unless the equipment is electrically isolated.

If there is unlocked access to the rear of the equipment, care should be taken by all personnel to avoid electric shock or energy hazards.

Voltage and current connections should be made using insulated crimp terminations to ensure that terminal block insulation requirements are maintained for safety. To ensure that wires are correctly terminated, the correct crimp terminal and tool for the wire size should be used.

Before energising the equipment it must be earthed using the protective earth terminal, or the appropriate termination of the supply plug in the case of plug connected equipment. Omitting or disconnecting the equipment earth may cause a safety hazard.

The recommended minimum earth wire size is 2.5mm<sup>2</sup>, unless otherwise stated in the technical data section of the product documentation.

Before energising the equipment, the following should be checked:

1. Voltage rating and polarity;
2. CT circuit rating and integrity of connections;
3. Protective fuse rating;
4. Integrity of earth connection (where applicable)

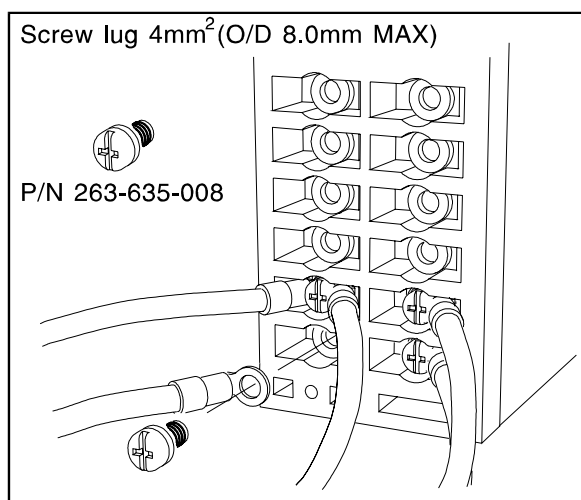



### **Current Transformer Circuits**

Do not open the secondary circuit of a live CT since the high voltage produced may be lethal to personnel and could damage insulation.

### **External Resistors**

Where external resistors are fitted to relays, these may present a risk of electric shock or burns, if touched.

### **Insulation & Dielectric Strength Testing**

Insulation testing may leave capacitors charged up to a hazardous voltage. At the end of each part of the test, the voltage should be gradually reduced to zero, to discharge capacitors, before the test leads are disconnected.

### **Insertion of Modules**

These must not be inserted into or withdrawn from equipment whilst it is energised, since this may result in damage.

### **Electrical Adjustments**

Pieces of equipment which require direct physical adjustments to their operating mechanism to change current or voltage settings, should have the electrical power removed before making the change, to avoid any risk of electric shock.

### **Mechanical Adjustments**

The electrical power to the relay contacts should be removed before checking any mechanical settings, to avoid any risk of electric shock.

### **Draw Out Case Relays**

Removal of the cover on equipment incorporating electromechanical operating elements, may expose hazardous live parts such as relay contacts.

### **Insertion & Withdrawal of Heavy Current Test Plugs**

When using a heavy current test plug, CT shorting links must be in place before insertion or removal, to avoid potentially lethal voltages.



Visit [www.rmspl.com.au](http://www.rmspl.com.au) for the latest product information.

Due to RMS continuous product improvement policy this information is subject to change without notice. User\_Guide-4/lss E/25/08/08



### **Commissioning Preliminaries**

Carefully examine the module and case to see that no damage has occurred during transit. Check that the relay serial number on the module, case and cover are identical, and that the model number and rating information are correct.

Carefully remove any elastic bands/packing fitting for transportation purposes.

Check that the external wiring is correct to the relevant relay diagram or scheme diagram. The relay diagram number appears inside the case.

Particular attention should be paid to the correct wiring and value of any external resistors indicated on the wiring diagram/relay rating information.

Note that shorting switches shown on the relay diagram are fitted internally across the relevant case terminals and close when the module is withdrawn. It is essential that such switches are fitted across all CT circuits.

If a test block system is to be employed, the connections should be checked to the scheme diagram, particularly that the supply connections are to the 'live' side of the test block.

### Earthing

Ensure that the case earthing connection above the rear terminal block, is used to connect the relay to a local earth bar.

### Insulation

The relay, and its associated wiring, may be insulation tested between:

- all electrically isolated circuits
- all circuits and earth

An electronic or brushless insulation tester should be used, having a dc voltage not exceeding 1000V. Accessible terminals of the same circuit should first be strapped together. Deliberate circuit earthing links, removed for the tests, subsequently must be replaced.



Visit [www.rmspl.com.au](http://www.rmspl.com.au) for the latest product information.

Due to RMS continuous product improvement policy this information is subject to change without notice. User\_Guide-4/lss E/25/08/08

## Commissioning Tests

If the relay is wired through a test block it is recommended that all secondary injection tests should be carried out using this block.

Ensure that the main system current transformers are shorted before isolating the relay from the current transformers in preparation for secondary injection tests.

### DANGER

DO NOT OPEN CIRCUIT THE SECONDARY CIRCUIT OF A CURRENT TRANSFORMER SINCE THE HIGH VOLTAGE PRODUCED MAY BE LETHAL AND COULD DAMAGE INSULATION.

It is assumed that the initial preliminary checks have been carried out.

### Relay CT shorting switches

With the relay removed from its case, check electrically that the CT shorting switch is closed.

### Primary injection testings

It is essential that primary injection testing is carried out to prove the correct polarity of current transformers.

Before commencing any primary injection testing it is essential to ensure that the circuit is dead, isolated from the remainder of the system and that only those earth connections associated with the primary test equipment are in position.

## Decommissioning & Disposal

**Decommissioning:** The auxiliary supply circuit in the relay may include capacitors across the supply or to earth. To avoid electric shock or energy hazards, after completely isolating the supplies to the relay (both poles of any dc supply), the capacitors should be safely discharged via the external terminals prior to decommissioning.

**Disposal:** It is recommended that incineration and disposal to water courses is avoided. The product should be disposed of in a safe manner.

## Maintenance

### Mechanical Inspection

#### Relay Assembly

Inspect the relay for obvious signs of damage or ingress of moisture or other contamination.

#### Relay Module

Isolate the relay, remove the front cover & carefully withdraw the relay module from the case.

Care must be taken to avoid subjecting the relay element to static discharge which may damage or degrade sensitive electronic components.

Inspect the relay module for signs of any overheating or burn marks which may have been caused by overvoltage surge or transient conditions on the power supply or digital status inputs.

Inspect the VT & CT stages for degradation of insulation on the terminal wiring & transformer windings.

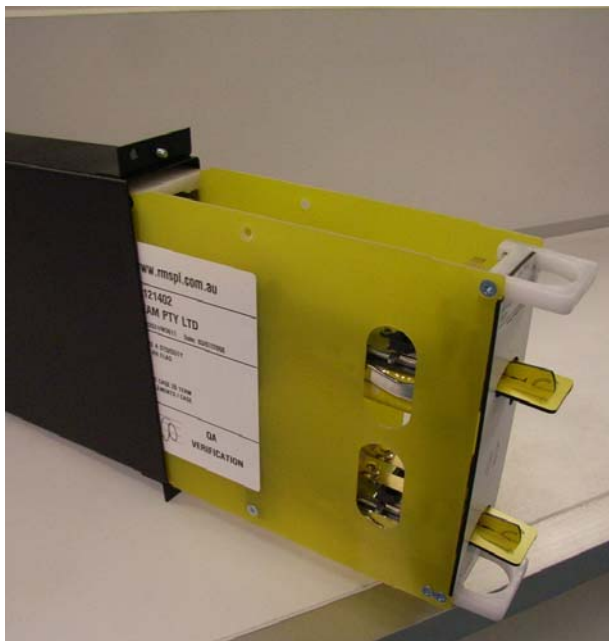

Remove cover by unscrewing black thumb screws & withdraw the relay module from the case.

## Relay Case

Inspect the outer terminals checking insulation integrity & tightness.

Inspect inside the case and use a blower to remove dust.

Inspect the inner terminals for worn, distorted or tarnished contacts and if necessary clean the contacts using a brush dipped in a suitable substance.

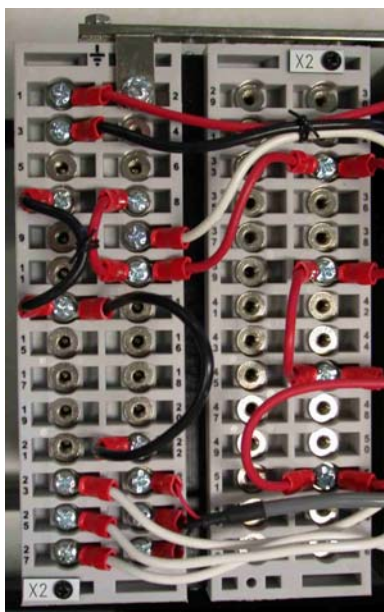

Case outer terminals



Case inner terminals



Module plug in terminals

## **Test Intervals**

The maintenance tests required will largely depend upon experience and site conditions, but as a general rule it is recommended that the following inspection and tests are performed every twelve months.

- ◆ Mechanical Inspection
- ◆ Check of Connections
- ◆ Insulation Resistance Test
- ◆ Fault Setting Tests by Secondary Injection
- ◆ Tests using Load Current
- ◆ Check the continuity of the neutral CT loop with a bell test set or an ohmmeter





## Defect Report Form

Please copy this sheet and use it to report any defect which may occur.

Customers Name & Address:	Contact Name:
	Telephone No:
	Fax No:
Supplied by:	Date when installed:
Site:	Circuit:

### When Defect Found

Date:	Commissioning?	Maintenance?	Systems Fault?	Other, Please State:
Product Part No:			Serial Number:	
Copy any message displayed by the relay:				
Describe Defect:				
Describe any other action taken:				
Signature:		Please Print Name:		Date:

### For RMS use only

Date Received:	Contact Name:	Reference No:	Date Acknowledged:	Date of Reply:	Date Cleared:
----------------	---------------	---------------	--------------------	----------------	---------------



Visit [www.rmspl.com.au](http://www.rmspl.com.au) for the latest product information.

Due to RMS continuous product improvement policy this information is subject to change without notice. User\_Guide-5/Iss D/10/07/08

## **Australian Content**

Unless otherwise stated the product(s) quoted are manufactured by RMS at our production facility in Melbourne Australia. Approximately 60% of our sales volume is derived from equipment manufactured in house with a local content close to 90%. Imported components such as semi-conductors are sourced from local suppliers & preference is given for reasonable stock holding to support our build requirements.

## **Quality Assurance**

RMS holds NCSI (NATA Certification Services International), registration number 6869 for the certification of a quality assurance system to AS/NZS ISO9001-2008. Quality plans for all products involve 100% inspection and testing carried out before despatch. Further details on specific test plans, quality policy & procedures may be found in section A4 of the RMS product catalogue.

## **Product Packaging**

Protection relays are supplied in secure individual packing cardboard boxes with moulded styrene inserts suitable for recycling. Each product & packing box is labeled with the product part number, customer name & order details.

## **Design References**

The products & components produced by RMS are based on many years of field experience since Relays Pty Ltd was formed in 1955. A large population of equipment is in service throughout Australia, New Zealand, South Africa & South East Asia attesting to this fact. Specific product & customer reference sites may be provided on application.

## **Product Warranty**

All utility grade protection & auxiliary relay products, unless otherwise stated, are warranted for a period of 24 months from shipment for materials & labour on a return to factory basis. Repair of products damaged through poor application or circumstances outside the product ratings will be carried out at the customer's expense.

## **Standard Conditions of Sale**

Unless otherwise agreed RMS Standard Terms & Conditions (QF 907) shall apply to all sales. These are available on request or from our web site.



## **Relay Monitoring Systems Pty Ltd**

6 Anzed Court, Mulgrave, Victoria 3170, AUSTRALIA

Tel: +61 3 8544 1200 Fax: +61 3 8544 1201 Email: [rms@rmspl.com.au](mailto:rms@rmspl.com.au) Web: [www.rmspl.com.au](http://www.rmspl.com.au)