



4M400 / 4M420 User Guide

Test Block System

relay monitoring systems pty ltd

Advanced Protection Devices



User Guide



Visit www.rmspl.com.au for the latest product information.

Due to RMS continuous product improvement policy this information is subject to change without notice. 4M400_Guide/Iss A/1/08/12

4M400 User Guide

About This Manual

This User Guide covers all 4M400 Test Blocks manufactured from August 2012. Earlier Test Blocks do not necessarily incorporate all the features described. Our policy of continuous development means that extra features & functionality may have been added.

The 4M400 User Guide is designed as a generic document to describe the common operating parameters for all Test Blocks built on this platform. Some relay applications are described but for specific model information the individual "K" number Product / Test manuals should be consulted.

The copyright and other intellectual property rights in this document, and in any model or article produced from it (and including any Registered or unregistered design rights) are the property of Relay Monitoring Systems Pty Ltd. No part of this document shall be reproduced or modified or stored in another form, in any data retrieval system, without the permission of Relay Monitoring Systems Pty Ltd, nor shall any model or article be reproduced from this document without consent from Relay Monitoring Systems Pty Ltd.

While the information and guidance given in this document is believed to be correct, no liability shall be accepted for any loss or damage caused by any error or omission, whether such error or omission is the result of negligence or any other cause. Any and all such liability is disclaimed.

Contact Us

© Relay Monitoring Systems Pty Ltd 2006-2012
6 Anzed Court • Mulgrave 3170 • AUSTRALIA
Phone 61 3 8544 1200 • Fax 61 3 8544 1201
Email rms@rmspl.com.au • Web www.rmspl.com.au

To download a PDF version of this guide:

http://www.rmspl.com.au/userguide/4m400_4m420_user_guide.pdf

To download the model specific Product Test Manual:

<http://www.rmspl.com.au/search.asp>



Part

1

How this Guide is Organised

This guide is divided into five parts:

Part 1 Overview

Part 2 Documentation

Part 3 Application

Part 4 Installation Preliminaries

Part 5 Maintenance



Visit www.rmspl.com.au for the latest product information. Page

Due to RMS continuous product improvement policy this information is subject to change without notice. 4M400_Guide/IssA/1/08/12



Documentation

Technical Bulletin

The detailed technical attributes, functional description & performance specifications for the 4M400 are described in the product Technical Bulletin. For the most up to date version go to:

www.rmspl.com.au/handbook/4m400.pdf

The order of precedence for product information is as follows:

- Product Test Manual (PTM)
- Technical Bulletin
- User Guide

User Guide

This User Guide covers all 4M400 relay versions & describes the generic features & attributes common across all versions.

The product ordering code described in the Technical Bulletin is used to generate a unique version of the relay specification & is called a Type Number. This code takes the form 4M400Kxx where the Kxx is the "K" or version number. For a complete description of the RMS "K" number system refer to:

www.rmspl.com.au/handbook/parta3.pdf

Product Test Manual

Each 4M400 version has a specific PTM which provides details on the unique attributes of the relay. Each PTM includes the following information:

- Specific technical variations from the standard model if applicable
- Wiring diagram

If you require a copy of the PTM for an RMS product the following options are available:

- Check the RMS web site at: www.rmspl.com.au/search.asp
- RMS CD catalogue select: [List all Product/Test Manuals](#) under [Technical Library](#)
- Contact RMS or a representative & request a hard copy or PDF by email.



Application

Test Block System	2
Test Block Components	2
Test Block Usage	3
Stage 1 Isolation.....	3
Stage 2 Isolation.....	3
Test Plug Insertion	4
Test Block Installation	5
Test Block Location	5
Test Block Mounting.....	5
4M400 Applications	6
4M400 Connection diagram	6
Commissioning	11
Commissioning Preliminaries.....	11
Site Commissioning Verification Checklist.....	11
Continuity and Functionality Testing of 4M300 Test Block	11
Functionality Testing of 4M300 Test Block with 4M320 Test Plug	12

Test Block System

Test Block Components

The 4M400 Test Block system is made up of 4 main components.

- Test Block
- Isolation Plug
- Test Block Cover
- 4M420 Test Plug



Complete 4M400 Test Block

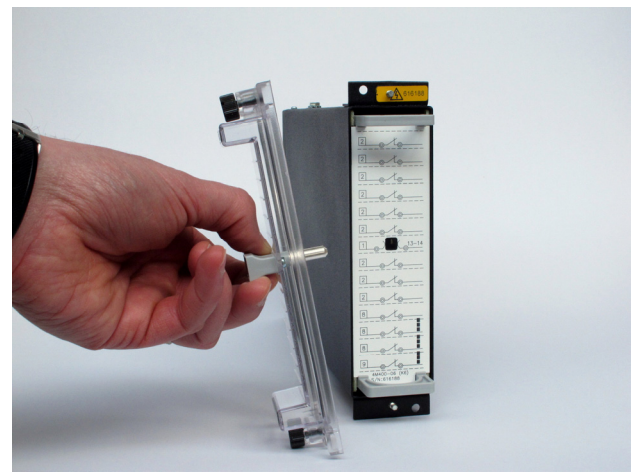

4M400 Test Block

Front Cover Removed - Stage 1 Isolation



4M400 Test Block

Isolation Plug Removed - Stage 2 Isolation



4M420 Test Plug

Test Block Usage

Stage 1 Isolation



Undo Front Cover Thumbscrews to allow Front Cover Removal

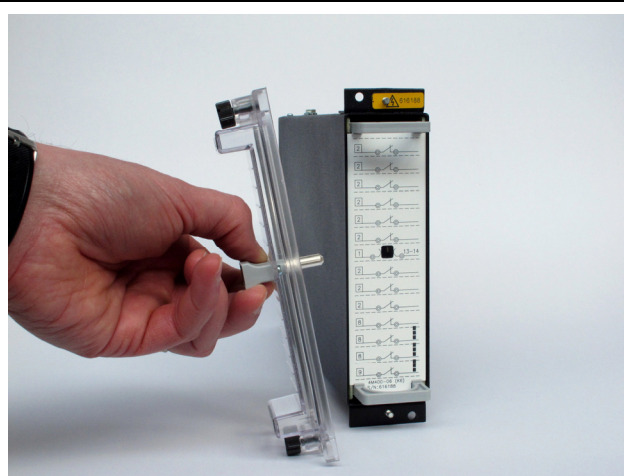

Front Cover Removed - Stage 1 Isolation Completed

Stage 2 Isolation

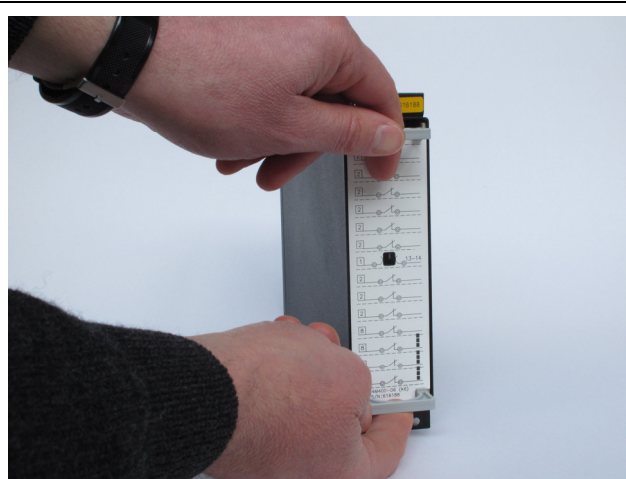

Withdraw Isolation Plug - to Automatically short CT circuits

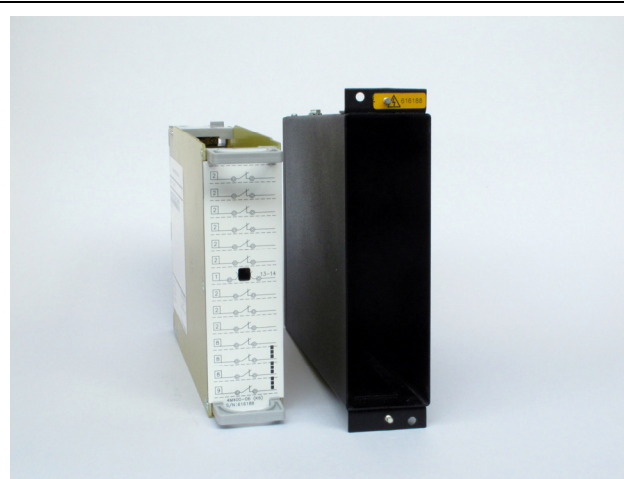

Isolation Plug Removed - Stage 2 Isolation Completed

Test Plug Insertion

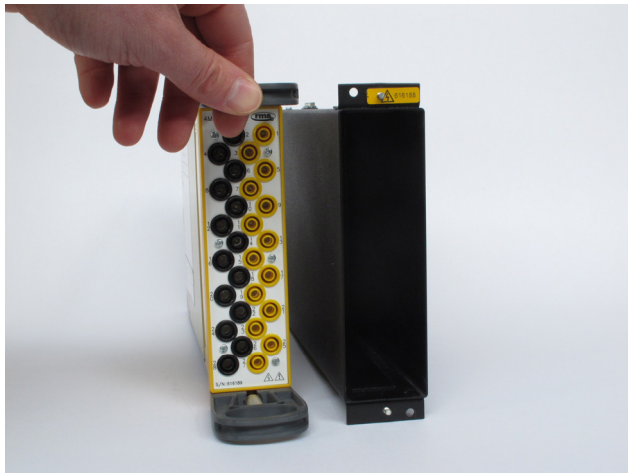

4M420 Test Plug may be inserted into test block

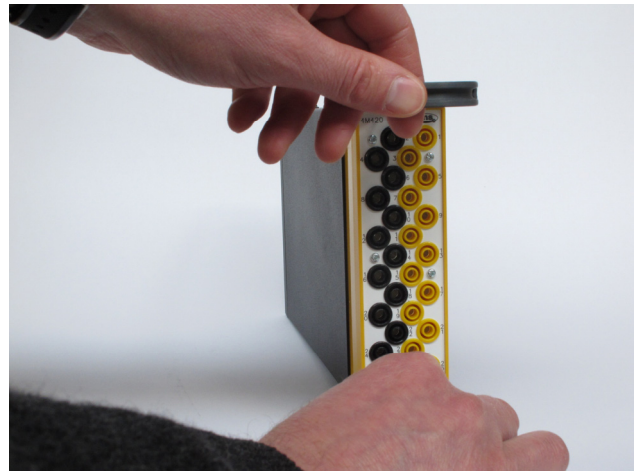

Test Plug inserted into test block, tighten thumb screws to retain in position

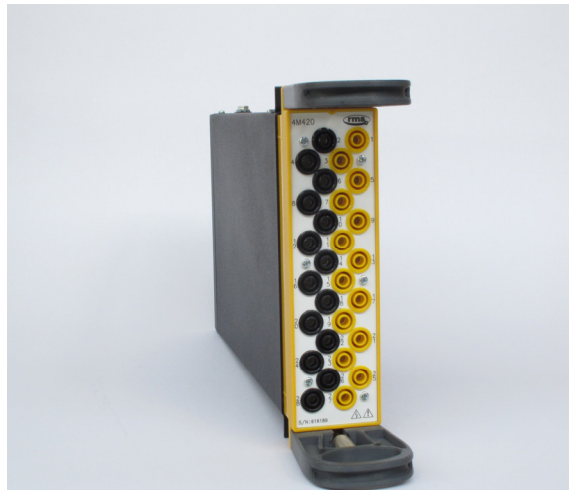

Test Plug ready for testing

Test Block Installation

Test Block Location

The purpose of the 4M400 Test Block is to provide a convenient and safe means of undertaking routine or emergency secondary injection testing of Protection and Metering schemes.

The positioning of the 4M400 Test Block should ideally be on the front of the cubicle or panel and in close proximity to the equipment to be tested. The Test block needs to be located so that it is readily accessible by Testing personnel.

Test Block Mounting

The 4M400 Test Block is housed in a size 2 case with 28 terminals and provides for either flush panel mounting or 4U high 19 inch rack frame mounting.

Connection to the 4M400 is achieved via 4mm screw terminals.

The case dimensions and Panel cut out details are provided below.

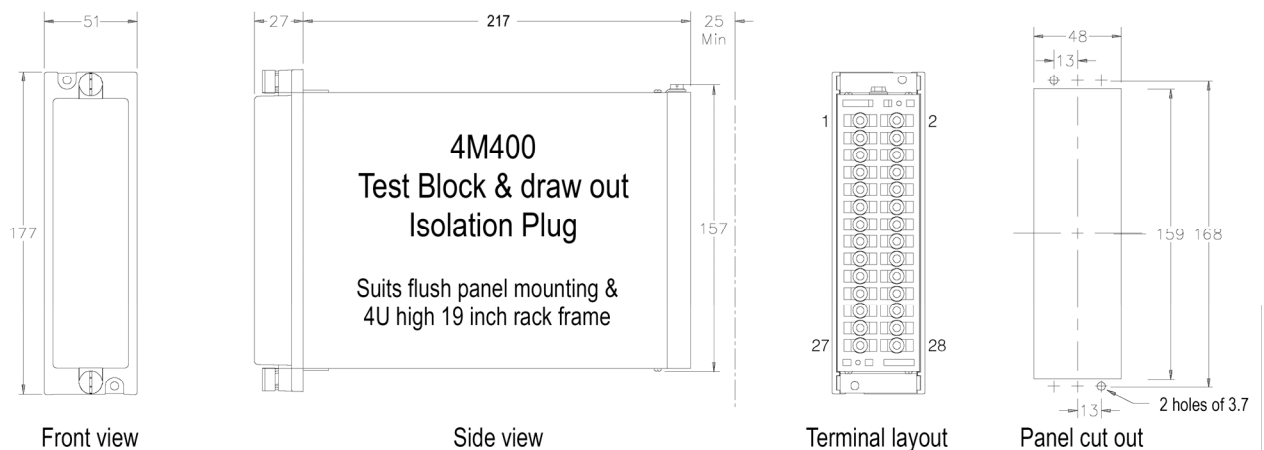

Recommended Wiring Layout

It is recommended that the Test Block is wired with connections to the protective relay or protection scheme made to the EVEN numbered equipment side terminals. Connections to CT's, VT's and CB circuitry should be made to the ODD numbered live side terminals on the Test Block.

This arrangement ensures that when the Test Plug is used, the sockets in the black half of the plug are the isolated relay circuits and sockets on the yellow half are connected to the potentially live supplies as shown in the Applications section.

4M400 Applications

Order Code Cross Reference Chart

A functionally equivalent 4M400 Test Block solution is available for most common test block systems available on the market.

		RMS Codes
MMLG-01	2RMLG-01	4M400-06
MMLG-02	2RMLG-02	4M400-07
MMLG-07	2RMLG-07	4M400-07
MMLG-08	2RMLG-08	4M400-08
	2RMLG-09	4M400-09

The above 4M400 variants provide internal CT shorting as standard.

The common 4M420 Test Plug is compatible with all RMS coded 4M400 test blocks.

Application for a 3 Phase Overcurrent and EF Protection Scheme

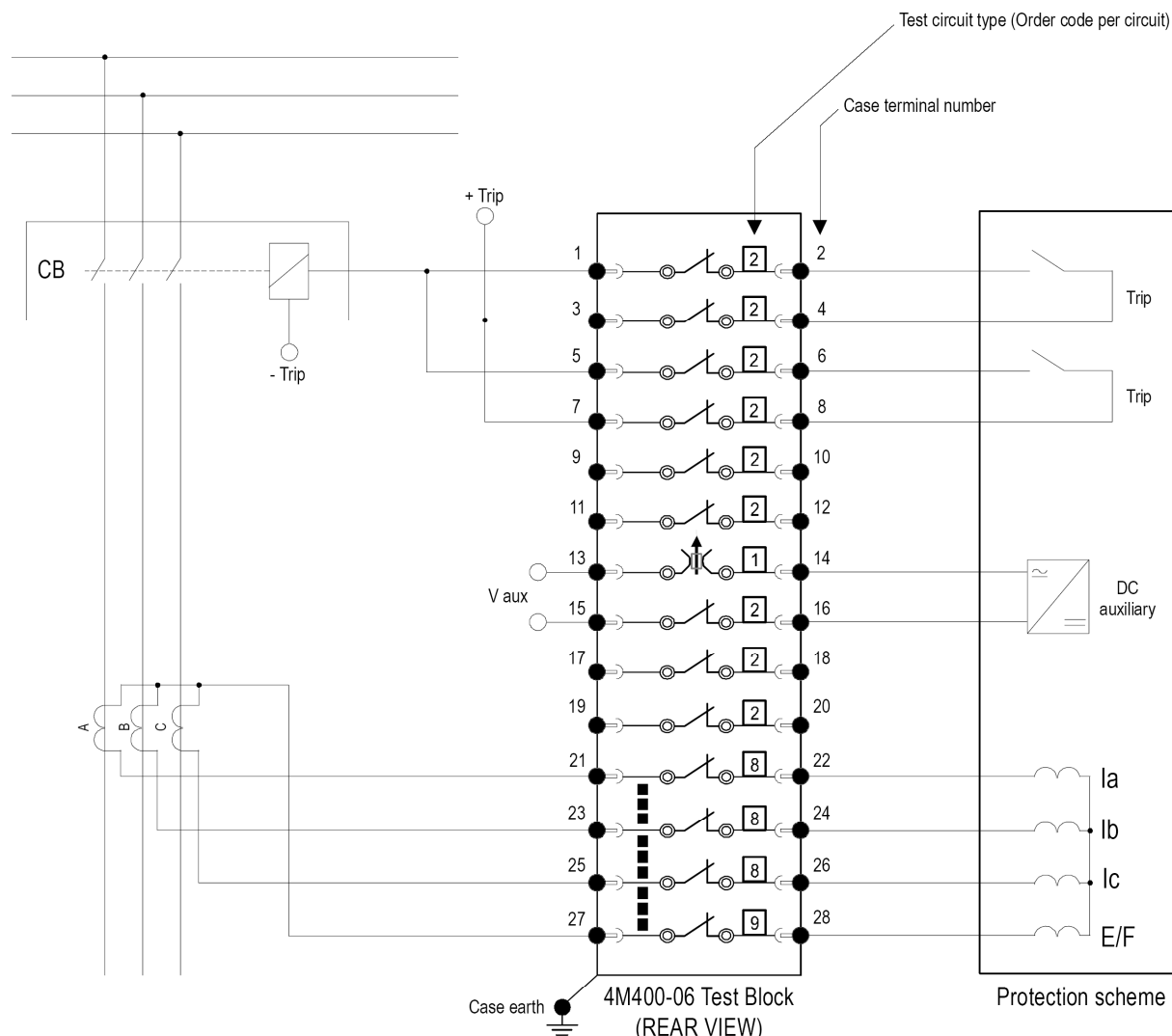

■ Automatic CT shorting bar engages before circuit is isolated

RMS Order Code 4M400-06

The Even Numbered terminals of the 4M400 Test Block correspond to the **BLACK** coloured Even Numbered sockets of the 4M320 Test Plug (access to the Protection scheme).

The Odd Numbered terminals of the 4M400 Test Block correspond to the **YELLOW** coloured Odd Numbered sockets of the 4M320 Test Plug (access to the potentially live supplies).

In this application removal of the front cover disconnects terminals 13 and 14 and removes the DC auxiliary supply to the protection scheme. When the 4M320 Test Plug is inserted, sockets 13 and 14 need to be connected to restore the auxiliary supply to the protection scheme.

Application for a Directional 3 Phase Overcurrent and EF Protection Scheme

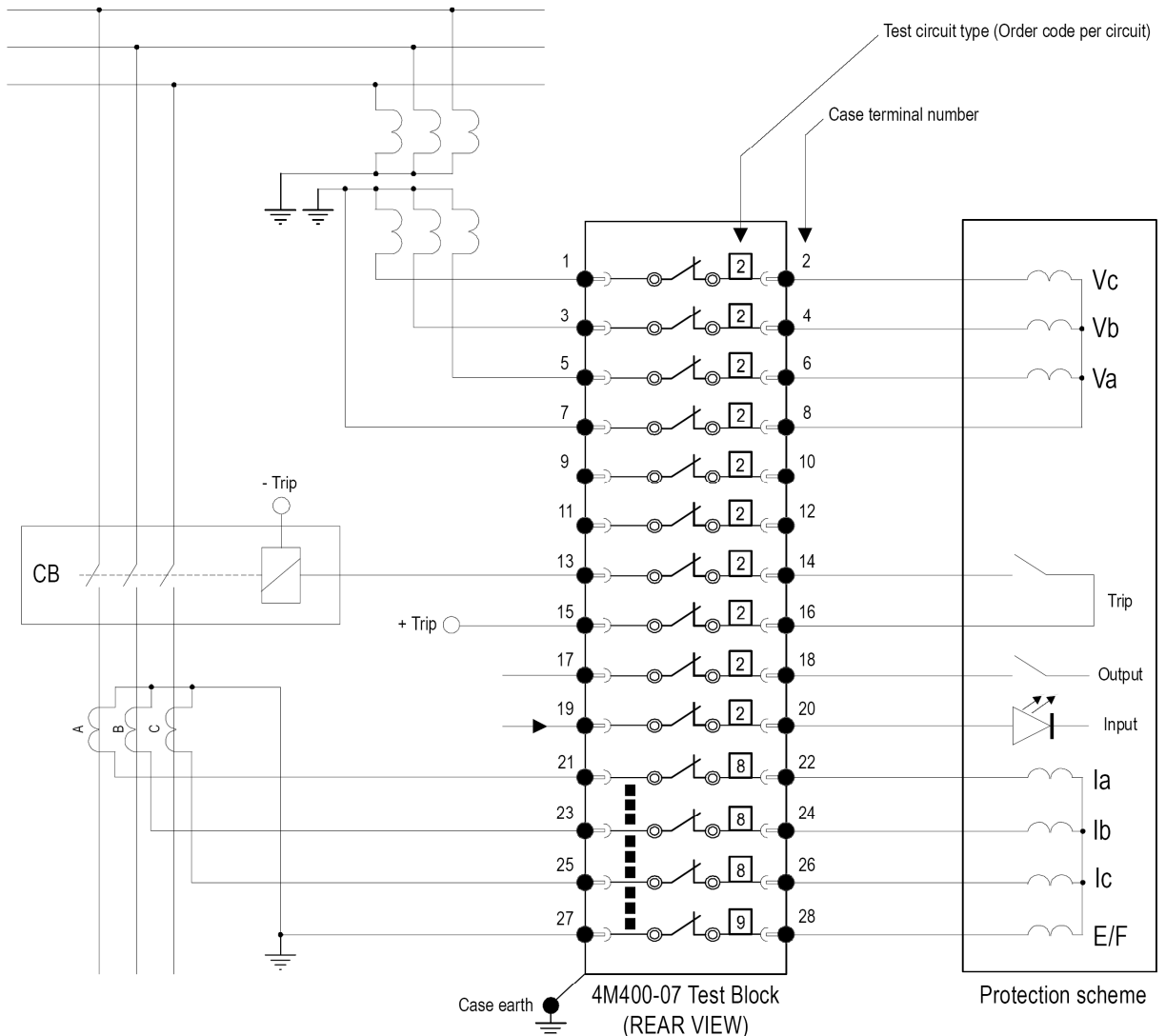

■ Automatic CT shorting bar engages before circuit is isolated

Scheme is also applicable for Distance Protection Schemes.

RMS Order Code 4M400-07

The Even Numbered terminals of the 4M400 Test Block correspond to the **BLACK** coloured Even Numbered sockets of the 4M320 Test Plug (access to the Protection scheme).

The Odd Numbered terminals of the 4M400 Test Block correspond to the **YELLOW** coloured Odd Numbered sockets of the 4M320 Test Plug (access to the potentially live supplies).

Application for 3 Phase CT's and Core Balance E/F CT

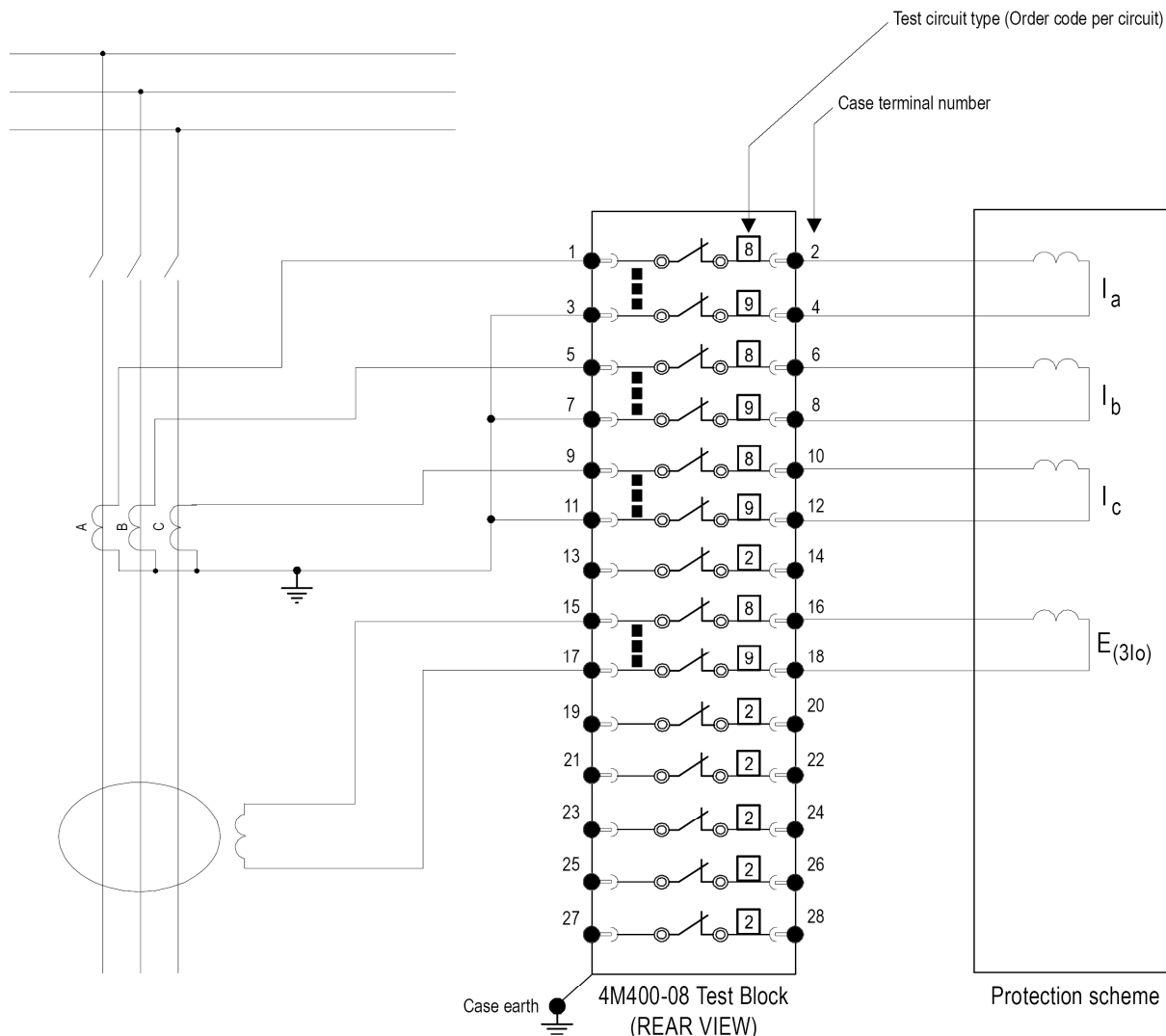

Automatic CT shorting bar engages before circuit is isolated

RMS Order Code 4M400-08

The Even Numbered terminals of the 4M400 Test Block correspond to the **BLACK** coloured Even Numbered sockets of the 4M320 Test Plug (access to the Protection scheme).

The Odd Numbered terminals of the 4M400 Test Block correspond to the **YELLOW** coloured Odd Numbered sockets of the 4M320 Test Plug (access to the potentially live supplies).

Application for Differential Protection of Transformers

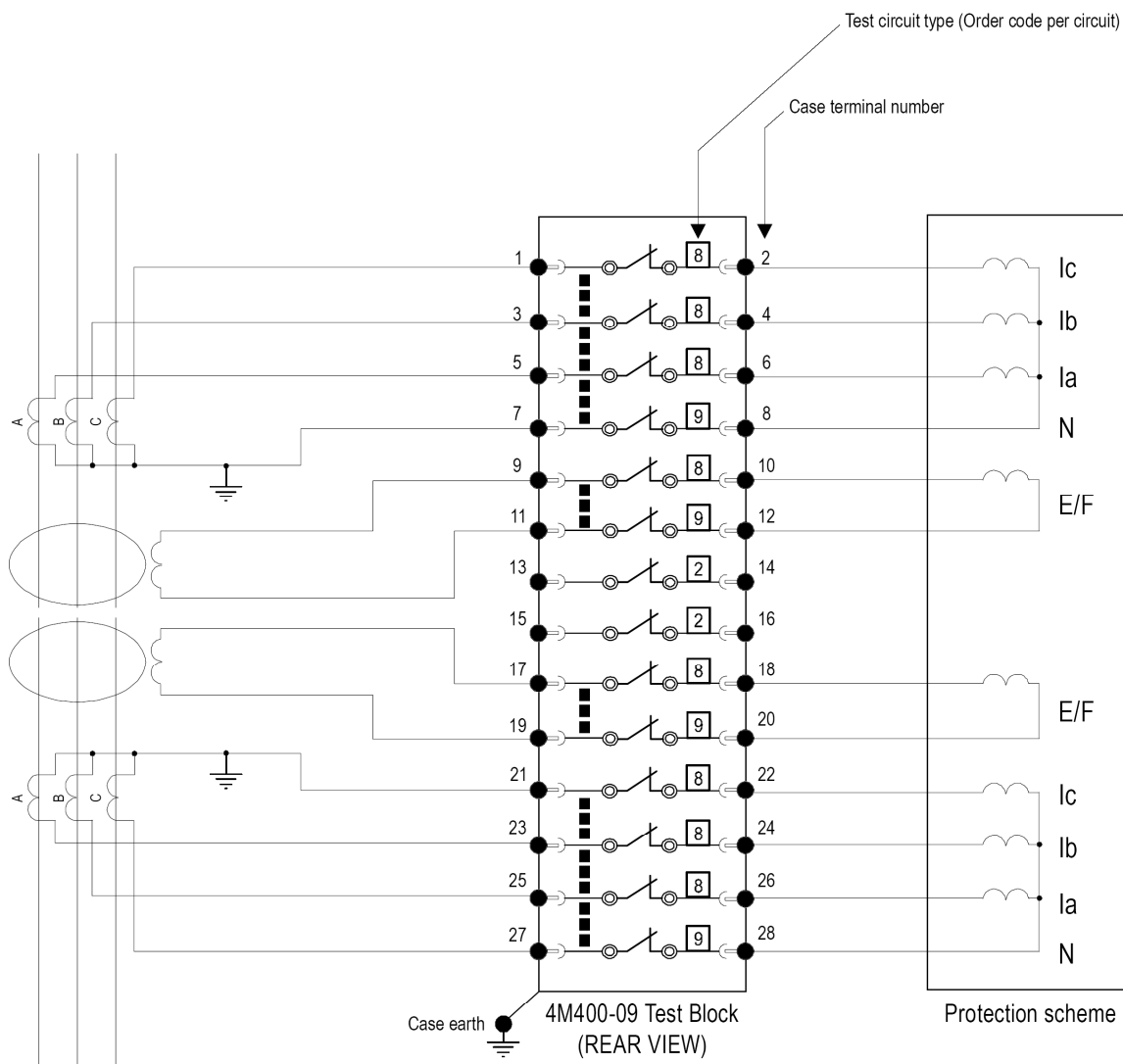

■ Automatic CT shorting bar engages before circuit is isolated

RMS Order Code 4M400-09

The Even Numbered terminals of the 4M400 Test Block correspond to the BLACK coloured Even Numbered sockets of the 4M320 Test Plug (access to the Protection scheme).

The Odd Numbered terminals of the 4M400 Test Block correspond to the YELLOW coloured Odd Numbered sockets of the 4M320 Test Plug (access to the potentially live supplies).

Commissioning

Commissioning Preliminaries

Carefully examine the module to ensure that no damage has occurred during transit. Check that the model number and rating information are correct.

Insulation

The test block, and its associated wiring, may be insulation tested between:

- all electrically isolated circuits
- all circuits and earth

An electronic or brushless insulation tester should be used, having a dc voltage not exceeding 1000V. Accessible terminals of the same circuit should first be strapped together. Deliberate circuit earthing links, removed for the tests, subsequently must be replaced.

Site Commissioning Verification Checklist

Observe all site specific standard safety procedures.

The following tests are undertaken following the completion of all 4M400 Test Block wiring.

Continuity and Functionality Testing of 4M400 Test Block

Item	Description	Complete
1	Confirm all necessary primary equipment isolations	
2	Confirm all necessary secondary equipment isolations (including trip outputs)	
3	Check the 4M400 is wired to the protection design schematic	
4	Confirm the 4M400 Test Block Isolation Plug and Front Cover are fitted	
4	Confirm continuity of isolation circuits	
5	Perform Stage 1 isolation by removing Front Cover	
6	Confirm Stage 1 circuits are isolated	
7	Perform Stage 2 isolation by removing Test Block Isolation Plug	
8	Confirm all CT Circuits are Short Circuited and isolated from equipment to be tested	
9	Confirm Stage 2 circuits are isolated from equipment to be tested	

Functionality Testing of 4M400 Test Block with 4M420 Test Plug

Item	Description	Complete
1	With the Isolation Plug removed insert the 4M420 Test Plug	
2	Confirm continuity from the 4M420 test points to the secondary equipment under test	

Installation

Handling of Electronic Equipment

A person's normal movements can easily generate electrostatic potentials of several thousand volts. Discharge of these voltages into semiconductor devices when handling electronic circuits can cause serious damage, which often may not be immediately apparent but the reliability of the circuit will have been reduced.

The electronic circuits of Relay Monitoring Systems Pty Ltd products are immune to the relevant levels of electrostatic discharge when housed in the case. Do not expose them to the risk of damage by withdrawing modules unnecessarily.

Each module incorporates the highest practicable protection for its semiconductor devices. However, if it becomes necessary to withdraw a module, the following precautions should be taken to preserve the high reliability and long life for which the equipment has been designed and manufactured.

1. Before removing a module, ensure that you are at the same electrostatic potential as the equipment by touching the case.
2. Handle the module by its front-plate, frame, or edges of the printed circuit board.
3. Avoid touching the electronic components, printed circuit track or connectors.
4. Do not pass the module to any person without first ensuring that you are both at the same electrostatic potential. Shaking hands achieves equipotential.
5. Place the module on an antistatic surface, or on a conducting surface which is at the same potential as yourself.
6. Store or transport the module in a conductive bag.

If you are making measurements on the internal electronic circuitry of an equipment in service, it is preferable that you are earthed to the case with a conductive wrist strap.

Wrist straps should have a resistance to ground between 500k – 10M ohms. If a wrist strap is not available, you should maintain regular contact with the case to prevent the build up of static.

Instrumentation which may be used for making measurements should be earthed to the case whenever possible.

Safety Section

This Safety Section should be read before commencing any work on the equipment.

The information in the Safety Section of the product documentation is intended to ensure that products are properly installed and handled in order to maintain them in a safe condition. It is assumed that everyone who will be associated with the equipment will be familiar with the contents of the Safety Section.

Explanation of Symbols & Labels

The meaning of symbols and labels which may be used on the equipment or in the product documentation, is given below.

Caution: refer to product information



Caution: risk of electric shock

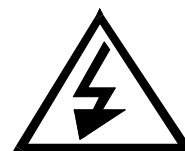

Functional earth terminal

Note: this symbol may also be used for a protective/safety earth terminal if that terminal is part of a terminal block or sub-assembly eg. power supply.

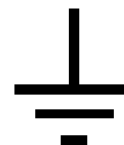



Unpacking

Upon receipt inspect the outer shipping carton or pallet for obvious damage.

Remove the individually packaged relays and inspect the cartons for obvious damage.

To prevent the possible ingress of dirt the carton should not be opened until the relay is to be used. Refer to the following images for unpacking the relay:



Outer packing carton showing shipping documentation pouch.
Address label on top of carton.

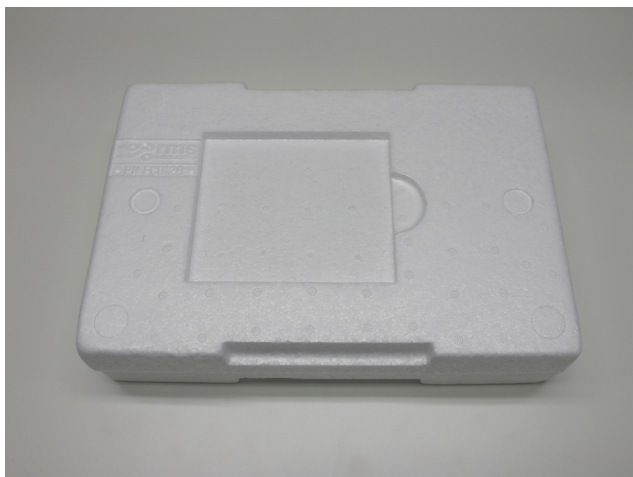

Inner packing system for bulk packaging of ten (10) Test Blocks per carton.



Visit www.rmspl.com.au for the latest product information.

Due to RMS continuous product improvement policy this information is subject to change without notice. User_Guide-4/lss A/06/09/12



Unpacking (Continued)



Individual inner packing carton with lid open showing 4M400 Test Block.



Inner packing carton with lid open showing 4M420 Test Plug.



4M400 Isolation Plug shown removed from the 4M300 outer case.



Visit www.rmspl.com.au for the latest product information.

Due to RMS continuous product improvement policy this information is subject to change without notice. User_Guide-4/lss A/06/09/12

Accessories Supplied With Each Relay



Self threading M4 mounting screws



M4 terminal screws with captured lock washers

Storage & Handling

If damage has been sustained a claim should immediately be made against the carrier, also inform Relay Monitoring Systems Pty Ltd and the nearest RMS agent

When not required for immediate use, the relay should be returned to its original carton and stored in a clean, dry place.

Relays which have been removed from their cases should not be left in situations where they are exposed to dust or damp. This particularly applies to installations which are being carried out at the same time as constructional work.

If relays are not installed immediately upon receipt they should be stored in a place free from dust and moisture in their original cartons.

Dust which collects on a carton may, on subsequent unpacking, find its way into the relay; in damp conditions the carton and packing may become impregnated with moisture and the de-humidifying agent will lose its efficiency.



Equipment Operating Conditions

The equipment should be operated within the specified electrical and environmental limits.

Protective relays, although generally of robust construction, require careful treatment prior to installation and a wise selection of site. By observing a few simple rules the possibility of premature failure is eliminated and a high degree of performance can be expected.

Care must be taken when unpacking and installing the relays so that none of the parts are damaged or their settings altered and must at all times be handled by skilled persons only.

Relays should be examined for any wedges, clamps, or rubber bands necessary to secure moving parts to prevent damage during transit and these should be removed after installation and before commissioning.

The relay should be mounted on the circuit breaker or panel to allow the operator the best access to the relay functions.

Relay Dimensions & Other Mounting Accessories

Refer drawing in Technical Bulletin. Relevant Auto Cad files & details on other accessories such as 19 inch sub rack frames, semi projection mount kits & stud terminal kits may be down loaded from:

<http://www.rmspl.com.au/mseries.htm>



Visit www.rmspl.com.au for the latest product information.

Due to RMS continuous product improvement policy this information is subject to change without notice. User_Guide-4/lss A/06/09/12

Equipment Connections

Personnel undertaking installation, commissioning or servicing work on this equipment should be aware of the correct working procedures to ensure safety. The product documentation should be consulted before installing, commissioning or servicing the equipment.

Terminals exposed during installation, commissioning and maintenance may present hazardous voltage unless the equipment is electrically isolated.

If there is unlocked access to the rear of the equipment, care should be taken by all personnel to avoid electric shock or energy hazards.

Voltage and current connections should be made using insulated crimp terminations to ensure that terminal block insulation requirements are maintained for safety. To ensure that wires are correctly terminated, the correct crimp terminal and tool for the wire size should be used.

Before energising the equipment it must be earthed using the protective earth terminal, or the appropriate termination of the supply plug in the case of plug connected equipment. Omitting or disconnecting the equipment earth may cause a safety hazard.

The recommended minimum earth wire size is 2.5mm², unless otherwise stated in the technical data section of the product documentation.

Before energising the equipment, the following should be checked:

1. Voltage rating and polarity;
2. CT circuit rating and integrity of connections;
3. Protective fuse rating;
4. Integrity of earth connection (where applicable)

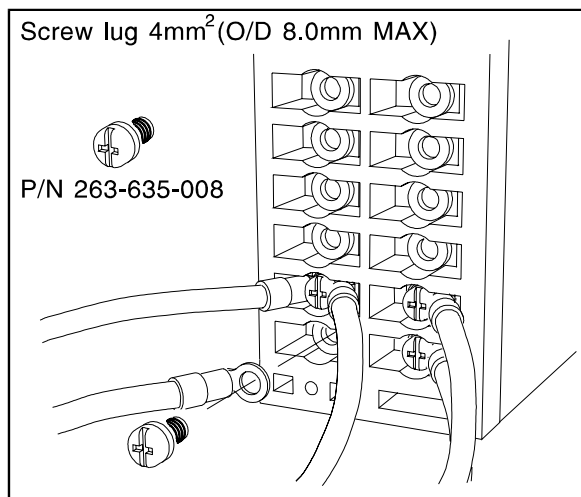



Current Transformer Circuits

Do not open the secondary circuit of a live CT since the high voltage produced may be lethal to personnel and could damage insulation.

External Resistors

Where external resistors are fitted to relays, these may present a risk of electric shock or burns, if touched.

Insulation & Dielectric Strength Testing

Insulation testing may leave capacitors charged up to a hazardous voltage. At the end of each part of the test, the voltage should be gradually reduced to zero, to discharge capacitors, before the test leads are disconnected.

Insertion of Modules

These must not be inserted into or withdrawn from equipment whilst it is energised, since this may result in damage.

Electrical Adjustments

Pieces of equipment which require direct physical adjustments to their operating mechanism to change current or voltage settings, should have the electrical power removed before making the change, to avoid any risk of electric shock.

Mechanical Adjustments

The electrical power to the relay contacts should be removed before checking any mechanical settings, to avoid any risk of electric shock.

Draw Out Case Relays

Removal of the cover on equipment incorporating electromechanical operating elements, may expose hazardous live parts such as relay contacts.

Insertion & Withdrawal of Heavy Current Test Plugs

When using a heavy current test plug, CT shorting links must be in place before insertion or removal, to avoid potentially lethal voltages.



Visit www.rmspl.com.au for the latest product information.

Due to RMS continuous product improvement policy this information is subject to change without notice. User_Guide-4/lss A/06/09/12



Commissioning Preliminaries

Carefully examine the module and case to see that no damage has occurred during transit. Check that the relay serial number on the module, case and cover are identical, and that the model number and rating information are correct.

Check that the external wiring is correct to the relevant relay diagram or scheme diagram. The relay diagram number appears inside the case.

Note that shorting switches shown on the relay diagram are fitted internally across the relevant case terminals and close when the module is withdrawn. It is essential that such switches are fitted across all CT circuits.

The connections should be checked to the scheme diagram, particularly that the supply connections are to the 'live' side of the test block.

Earthing

Ensure that the case earthing connection above the rear terminal block, is used to connect the relay to a local earth bar.

Insulation

The relay, and its associated wiring, may be insulation tested between:

- all electrically isolated circuits
- all circuits and earth

An electronic or brushless insulation tester should be used, having a dc voltage not exceeding 1000V. Accessible terminals of the same circuit should first be strapped together. Deliberate circuit earthing links, removed for the tests, subsequently must be replaced.



Visit www.rmspl.com.au for the latest product information.

Due to RMS continuous product improvement policy this information is subject to change without notice. User_Guide-4/lss A/06/09/12

Commissioning Tests

If the relay is wired through a test block it is recommended that all secondary injection tests should be carried out using this block.

Ensure that the main system current transformers are shorted before isolating the relay from the current transformers in preparation for secondary injection tests.

DANGER

DO NOT OPEN CIRCUIT THE SECONDARY CIRCUIT OF A CURRENT TRANSFORMER SINCE THE HIGH VOLTAGE PRODUCED MAY BE LETHAL AND COULD DAMAGE INSULATION.

It is assumed that the initial preliminary checks have been carried out.

Relay CT shorting switches

With the Isolation Plug removed from the 4M400, check electrically that the CT shorting switch is closed.

Primary injection testings

It is essential that primary injection testing is carried out to prove the correct polarity of current transformers.

Before commencing any primary injection testing it is essential to ensure that the circuit is dead, isolated from the remainder of the system and that only those earth connections associated with the primary test equipment are in position.

Decommissioning & Disposal

Decommissioning: The auxiliary supply circuit in the relay may include capacitors across the supply or to earth. To avoid electric shock or energy hazards, after completely isolating the supplies to the relay (both poles of any dc supply), the capacitors should be safely discharged via the external terminals prior to decommissioning.

Disposal: It is recommended that incineration and disposal to water courses is avoided. The product should be disposed of in a safe manner.

Maintenance

Mechanical Inspection

Relay Assembly

Inspect the relay for obvious signs of damage or ingress of moisture or other contamination.

Relay Module

Isolate the relay, remove the front cover & carefully withdraw the relay module from the case.

Care must be taken to avoid subjecting the relay element to static discharge which may damage or degrade sensitive electronic components.

Inspect the relay module for signs of any overheating or burn marks which may have been caused by overvoltage surge or transient conditions on the power supply or digital status inputs.

Inspect the VT & CT stages for degradation of insulation on the terminal wiring & transformer windings.

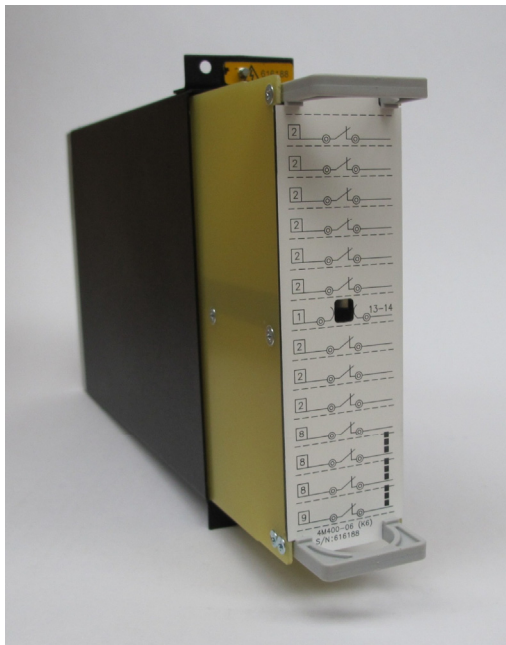

Remove cover by unscrewing black thumb screws & withdraw the relay module from the case.

Relay Case

Inspect the outer terminals checking insulation integrity & tightness.

Inspect inside the case and use a blower to remove dust.

Inspect the inner terminals for worn, distorted or tarnished contacts and if necessary clean the contacts using a brush dipped in a suitable substance.

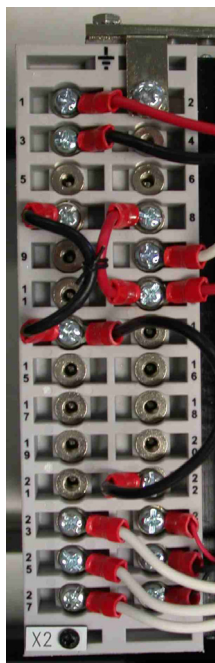

Case outer terminals

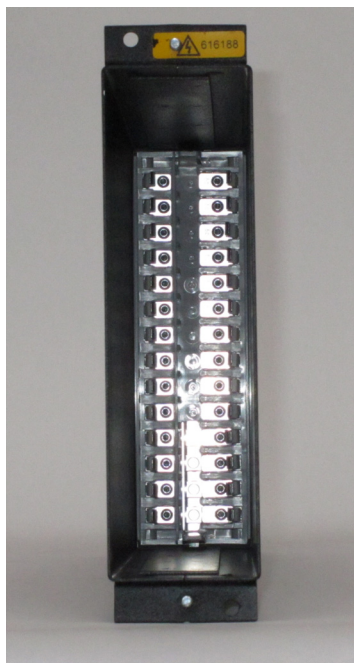

Case inner terminals



Module plug in terminals

Test Intervals

The maintenance tests required will largely depend upon experience and site conditions, but as a general rule it is recommended that the following inspection and tests are performed every twelve months.

- ◆ Mechanical Inspection
- ◆ Check of Connections
- ◆ Insulation Resistance Test



This page intentionally left blank



Visit www.rmspl.com.au for the latest product information.

Due to RMS continuous product improvement policy this information is subject to change without notice.



This page intentionally left blank



Visit www.rmspl.com.au for the latest product information.
Due to RMS continuous product improvement policy this information is subject to change without notice.



Defect Report Form

Please copy this sheet and use it to report any defect which may occur.

Customers Name & Address:	Contact Name:
	Telephone No:
	Fax No:
Supplied by:	Date when installed:
Site:	Circuit:

When Defect Found

Date:	Commissioning?	Maintenance?	Systems Fault?	Other, Please State:
Product Part No:			Serial Number:	
Copy any message displayed by the relay:				
Describe Defect:				
Describe any other action taken:				
Signature:		Please Print Name:		Date:

For RMS use only

Date Received:	Contact Name:	Reference No:	Date Acknowledged:	Date of Reply:	Date Cleared:
----------------	---------------	---------------	--------------------	----------------	---------------



Visit www.rmspl.com.au for the latest product information.

Due to RMS continuous product improvement policy this information is subject to change without notice. User_Guide-5/lss A/06/09/12

Australian Content

Unless otherwise stated the product(s) quoted are manufactured by RMS at our production facility in Melbourne Australia. Approximately 60% of our sales volume is derived from equipment manufactured in house with a local content close to 80%. Imported components such as semi-conductors are sourced from local suppliers & preference is given for reasonable stock holding to support our build requirements.

Quality Assurance

RMS holds NCSI (NATA Certification Services International), registration number 6869 for the certification of a quality assurance system to AS/NZS ISO9001-2008. Quality plans for all products involve 100% inspection and testing carried out before despatch. Further details on specific test plans, quality policy & procedures may be found in section A4 of the RMS product catalogue.

Product Packaging

Protection relays are supplied in secure individual packing cardboard boxes with moulded styrene inserts suitable for recycling. Each product & packing box is labeled with the product part number, customer name & order details.

Design References

The products & components produced by RMS are based on many years of field experience since Relays Pty Ltd was formed in 1955. A large population of equipment is in service throughout Australia, New Zealand, South Africa, The Middle East & South East Asia attesting to this fact. Specific product & customer reference sites may be provided on application.

Product Warranty

All utility grade protection & auxiliary relay products, unless otherwise stated, are warranted for a period of 24 months from shipment for materials & labour on a return to factory basis. Repair of products damaged through poor application or circumstances outside the product ratings will be carried out at the customer's expense.

Standard Conditions of Sale

Unless otherwise agreed RMS Standard Terms & Conditions (QF 907) shall apply to all sales. These are available on request or from our web site.



Relay Monitoring Systems Pty Ltd

6 Anzed Court, Mulgrave, Victoria 3170, AUSTRALIA

Tel: +61 3 8544 1200 Fax: +61 3 8544 1201 Email: rms@rmspl.com.au Web: www.rmspl.com.au