

/// Plug-in railway relay with 4/3 gold contacts

Rugged plug-in relays for extreme reliability, within long endurance applications and harsh environments

SBG

Latching relay

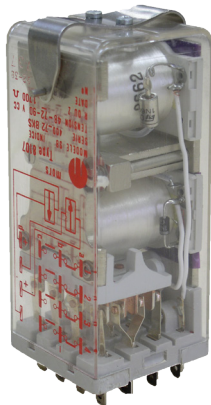

Description

The SBG is a latching safety critical relay with 2 stable magnetically latched states. When 1 coil is energized, the relay actuates from magnetically latched position 1 to 2. When the other coil is energized, the relay actuates back from magnetically latched position 2 to 1.

Two types of configuration are available:

- 400 type contact relays have 4 changeover double break contacts (Form Z)
- 300 type contact relays have 3 changeover double break contacts (Form Z) a 4th double break contact is reserved for automatic coupling of the coils. Contacts are gold plated on silver

The plug-in design offers secure locking feature for maximum ease of maintenance (no wires need to be disconnected or other hardware removed for relay inspection or replacement). The resistance to impact and vibration is conform to standards in force for Railway Transport Equipment.

Positive mechanical keying of relay to socket is built into relay and socket during manufacture and terminal identifications are clearly marked on identification plate that is permanently attached to the relay.

Application

The SBG latching relay allows the memory of the state of the circuit in case of power interruption.

Features

- Latching relay using 2 separate coils and magnetic rocker mechanism
- Two types available with 4 C/O (type 400) or 3 C/O (type 300) contacts, gold plated on silver
- All contacts are double make - double break contacts (form Z), 8 A
- Plug-in design with secure locking feature for maximum ease of maintenance
- Optional Weld no transfer contacts
- Contact life (mechanical) of 100 million cycles
- -40°C...+80 °C operating temperature

Connection diagram

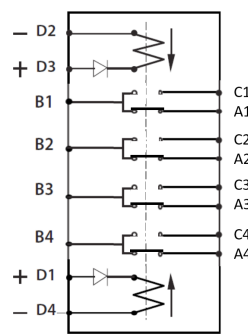

400 contact models ending in AK, DK & BK.

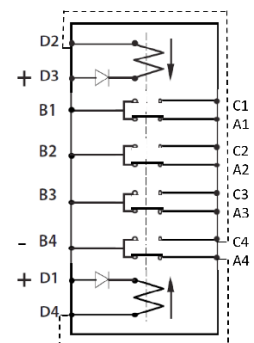

300 contact models ending in AL, DL & BL.

400 Contact Type Operation:

To operate this relay, it is recommended that the coil be actuated with a pulse of 50 ms min. duration. Assuming that before any voltage is applied to either coil all contacts are in position B-A, operation is as follows:

When a signal is applied to terminals D1-D4, the relay actuates and magnetically latches all contacts to the B-C position. A subsequent signal applied to terminals D2-D3 actuates the relay contacts from their magnetically latched position B-C back to their former magnetically latched position B-A. Note that a pulse of 50ms min. duration is required to operate the relay and that only one coil can be energized at a time.

300 Contact Type Operation:

This relay is designed for actuation of the coil with a permanent voltage. After connecting the negative terminal of the power supply to terminal B4 and assuming that before any voltage is applied to either coil, all contacts are in position B-A, operation is as follows;

When a positive signal from the power supply is applied to terminal D1, the relay actuates and magnetically latches all contacts to the B-C position. During this actuation, as contact B4-A4 switches to B4-C4, the power supply is effectively disconnected at positive terminal D1 and a new connection is made at terminal D3 so that power to the relay coil is ON only while B4-A4 is connected. A subsequent positive signal applied at terminal D3 actuates the relay contacts from their magnetically latched position B-C back to their former magnetically latched position B-A.

Note: Customer must make dotted connection shown external to socket as shown above.

Timing diagram

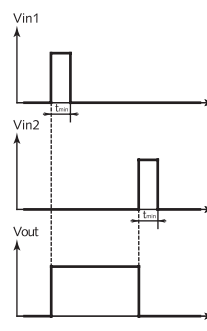

Railway compliancy

NF F 62-002
NF F16-101/102
EN 45445-2

Latching relay
SBG

Dimensions (mm)

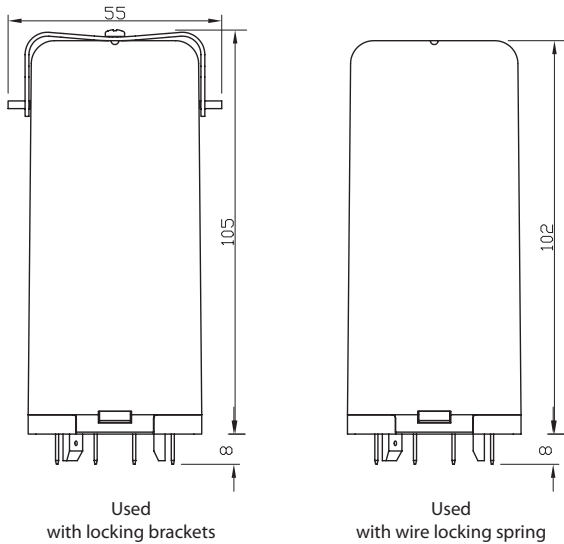

 **Over 10 million Mors Smitt relays in use in rail transport applications worldwide!**

Mors Smitt Asia Ltd.
Unit B & C, 25/F., Casey Aberdeen House
38 Heng Yip Road, Wong Chuk Hang
Hong Kong
Tel: +852 2343 555
sales.msa@wabtec.com

Mors Smitt France SAS
2 Rue de la Mandinière
72300 Sablé-sur-Sarthe, France
Tel: +33 (0) 243 92 82 00
sales.msf@wabtec.com

Mors Smitt UK Ltd.
Graycar Business Park,
Burton on Trent, DE13 8EN, UK
Tel: +44 (0)1283 357 263
sales.msuk@wabtec.com

Wabtec Netherlands B.V.
Vrieslantlaan 6,
3526 AA, Utrecht, Netherlands
Tel: +31 (0)30 288 1311
sales.msbv@wabtec.com

Mors Smitt Technologies Ltd.
1010 Johnson Drive,
Buffalo Grove, IL 60089-6918, USA
Tel: +1 847 777 6497
salesmst@wabtec.com

RMS Mors Smitt
6 Anzed Court,
Mulgrave, VIC 3170, Australia
Tel: +61 (0)3 8544 1200
sales.rms@wabtec.com

(c) Copyright 2018

All rights reserved. Nothing from this edition may be multiplied, or made public in any form or manner, either electronically, mechanically, by photocopying, recording, or in any manner, without prior written consent from Mors Smitt. This also applies to accompanying drawings and diagrams. Due to a policy of continuous development Mors Smitt reserves the right to alter the equipment specification and description outlined in this datasheet without prior notice and no part of this publication shall be deemed to be part of any contract for the equipment unless specifically referred to as an inclusion within such contract. Mors Smitt does not warrant that any of the information contained herein is complete, accurate, free from potential errors, or fit for any particular purpose. Mors Smitt does not accept any responsibility arising from any party's use of the information in this document.

Technical specifications

Latching relay SBG

Coil characteristics

Type	Keying	U _{nom} (VDC)	U _{operating} (VDC)	P _{nom} (W)	R _{coil} (Ω) ¹	L/R (ms) ²
400*	AK	24	18 / 33	3	185	30
	CK	36	25 / 45	3	430	30
	DK	48	33.5 / 60	3	750	30
	BK	72	48 / 90	3	1700	30
	SX	110	75 / 138	3	4000	30
300	AL	24	18 / 33	3	185	30
	CL	36	25 / 45	3	430	30
	DL	48	33.5 / 60	3	750	30
	BL	72	48 / 90	3	1700	30
	SY	110	75 / 138	3	4000	30

* 50 ms min pulse to permanent on (400 type only)

¹ Coil resistance tol.: ± 8 % at 20 °C

² Valid for closed relay

Contact data

Contact configuration	3 or 4 C/O double break contacts
Contact design	Stationary contact: 2 single contacts (contacts are in series) Movable contact: Solid blade
Contact resistance	≤ 20 mΩ at 5 A (carry only)
Maximum contact rating	Operating: 20 mA max. at 72 VDC Carry only (no make and break): 5 A max. at 5 VDC
Minimum contact rating	10 mA at 12 VDC
Contact material	Stationary contact: Gold plated over hard silver Movable contact: Gold over hard silver overlay laminated to copper

Contact design

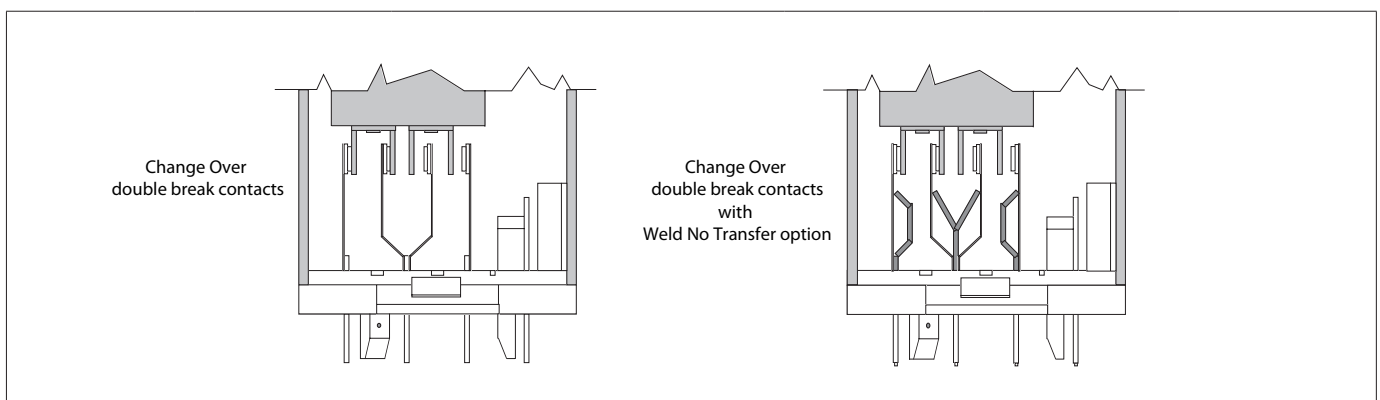

Latching relay SBG

Relay pin correspondence

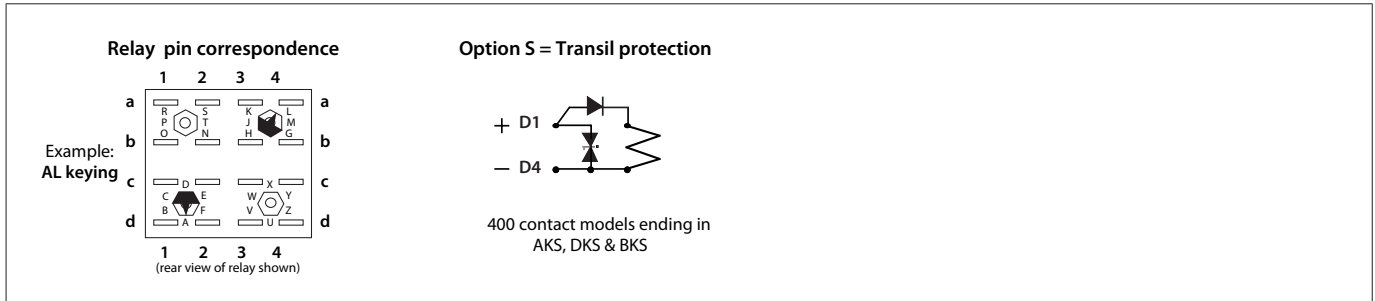

Electrical characteristics

Dielectric strength	2000 VAC, 1 min between contacts
Insulation resistance	≥ 1000 MΩ @ 500 VDC

Mechanical characteristics

Mechanical life	> 100 x 10 ⁶ operations
Weight	450 g

Environmental characteristics

Vibration	NF F 62-002	The tests are conducted in the X, Y , Z planes at frequency between 10 & 150 cycles (sinusoidal) at 2 g
Shock	NF F 62-002	Tests are applied in both directions in the X, Y & Z planes. Then successive shocks are administered consisting of the positive component of sinusoidal with a value of 30 g, 18 ms. Other vibration and shock tests can be performed on request.
Operating temperature		-40 °C...+80 °C
Humidity		93% RH, 40 °C for 4 days
Salt mist		5% NaCl, 35 °C for 4 days
Protection		IP40 (relay on socket)
Fire & smoke		Materials: Polycarbonate (cover) / Polyester Melamine (base)

Note: These materials have been tested for fire propagation and smoke emission according to standards NF F 16-101, NF F 16-102, ASTM E162 and ASTM E662, and have been approved to be used on the English/French train channel shuttle.

Railway compliancy

NF F 62-002	Rolling stock - Instantaneous relays contacts and sockets
NF F16-101/102	Railway rolling stock - Fire behavior
EN 45445-2	Railway applications - Fire protection on railway vehicles Part 2: Requirements for fire behavior of materials and components

Latching relay SBG

Electrical life expectancy

Dynamic relay selection curve No 1

AC Current breaking capacity versus life expectancy in millions of cycles.
Rate of contacts opening and closing = 1200 operations per hour.
Curves shown for resistive load (Power Factor = 1).

Curve	1	2	3	4
VAC	220	125	48	24

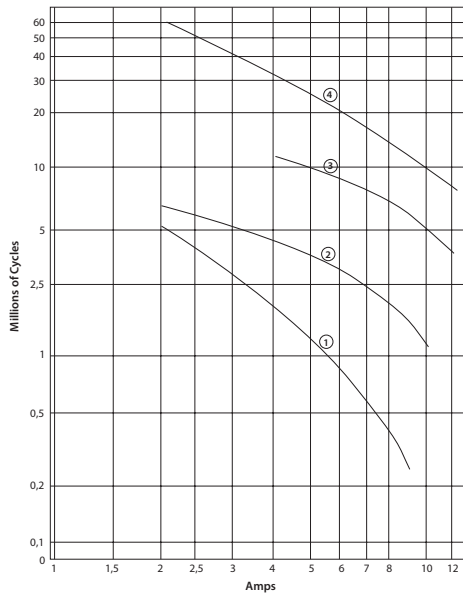

Dynamic relay selection curve No 2

DC Current breaking capacity versus life expectancy in millions of cycles.
Rate of contacts opening and closing = 1200 operations per hour.
Curves shown for inductive load:
— L/R= 20 ms continuous current
- - - L/R= 40 ms continuous current

* By connecting 2 contacts in series, DC current breaking capacity increases by 50 %

Curves	1-3	2-4	5-6	7-8
VDC	220	125	48	24

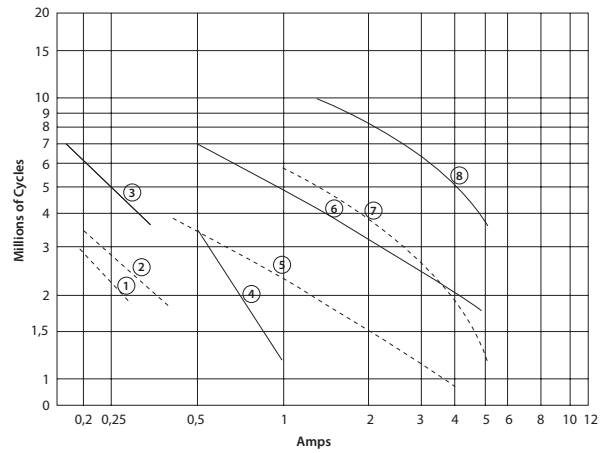

Dynamic relay selection curve No 3

DC Current breaking capacity versus life expectancy in millions of cycles.
Rate of contacts opening and closing = 1200 operations per hour.
Curves shown for resistive load (L/R = 0), Continuous current.

* By connecting 2 contacts in series, DC current breaking capacity increases by 50 %

Curve	1	2	3	4
VDC	220	125	48	24

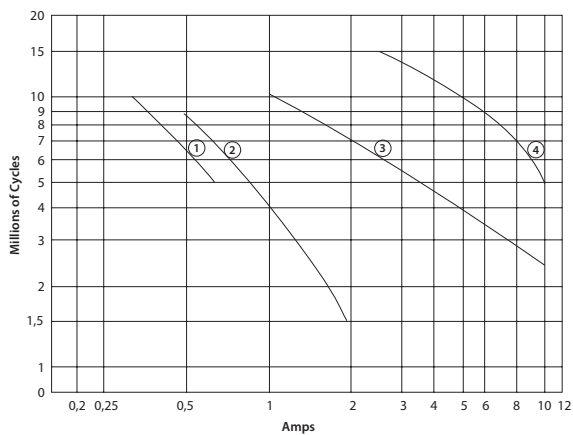

Dynamic relay selection curve No 4

Maximum contact breaking capacity versus voltage for a given L/R.
Rate of contacts opening and closing = 600 operations per hour.
Curves shown for resistive load (L/R=0) and inductive loads. Continuous current.
Life expectancy: 2 Millions of Cycles

Curve	1	2	3	4	5	6
L/R=	0ms	15ms	20ms	40ms	60ms	100ms

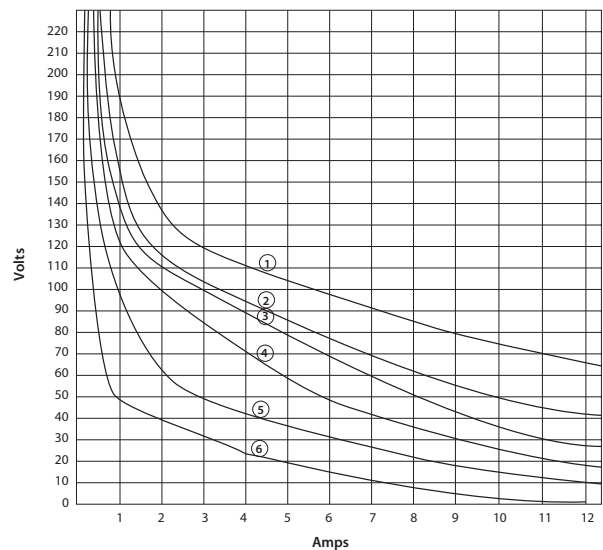

(for specific power contacts on customer circuitry only, not interchangeable into another socket with different customer circuitry configuration)

Latching relay SBG

Electrical life expectancy

Dynamic relay selection curve No 5

Maximum power interruption versus load time constant (L/R) for a given voltage.
Curves shown for resistive loads. $I = P/V$.

Curve	1	2	3	4	5
VDC	220	125	72	48	24

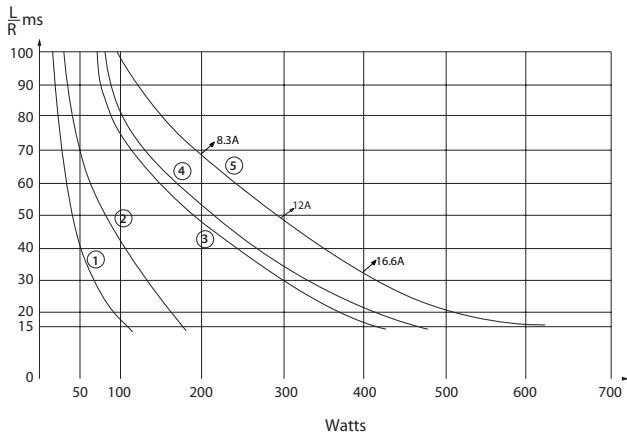

Dynamic relay selection curve No 6

AC Current breaking capacity versus life expectancy in millions of cycles.
Rate of contacts opening and closing = 1200 operations per hour.

Values shown for inductive loads -

- Cos ϕ = 0.7
- - - Cos ϕ = 0.5
- · - Cos ϕ = 0.3

Curves	1,3 &4	2,5 &7	6,9 &10	8,11 &12
VAC	220	125	48	24

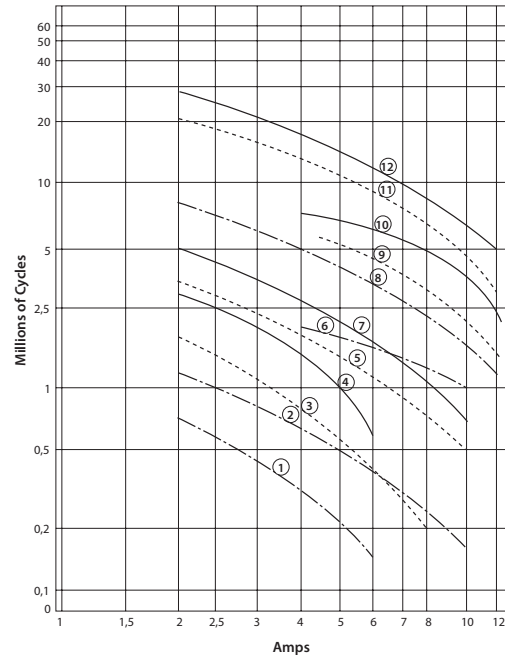

(for specific power contacts on customer circuitry only, not interchangeable into another socket with different customer circuitry configuration)

Latching relay SBG

Mounting possibilities/sockets



Panel/flush mounting

EA 102 B	Locking bracket (905843), rear connection, double Faston 5 mm
EA 102 BF	Wire locking spring (926853), rear connection, single Faston 5 mm
EA 104 B	Locking bracket (905843), rear connection, single Faston 5 x 0.8 mm
EA 104 BF	Wire locking spring (926853), rear connection, single Faston 5 x 0.8 mm
EA 111 BF	Spring clamp terminal, for surface or 35 mm rail, up to 2.5 mm ² wire terminal
EA 112 BF	Wire locking spring (926853), rear connection, crimp contact

Panel/flush mounting

EA 103 BF*	Wire locking spring (926853), front connection, M3 screw 6,5 mm ring terminals (2.5 mm ²)
EA 103 BF*	Wire locking spring (926853), front connection, single Faston 5 mm (3/16")

* Mounting possibility on 35 mm rail EN 50022 by adding suffix D to the part number (see socket datasheet)

Note: Keying of relay to socket can be specified by adding the keying letters in the part number. See all details in the related socket datasheet.

Latching relay SBG

Important for relay selection and operation

Make sure the relay is suitable for the application. For critical applications (for example: green loop applications) relays should be checked on correct working during periodic inspection.

Recommendations for long time contact reliability

For relays to enable failure free performance over a very long operational time, it is important to create the right circumstances. In any relay, contact usage and atmospheric conditions influence the contact surface. To counter this effect it is common practice to use a safety factor of > 2 to ensure long time contact reliability.

Therefore for long time contact reliability we recommend:

- Silver contacts: a minimum contact current of 20 mA per contact
- Gold contacts: a minimum contact current of 10 mA per contact
- Double Make Double Break contacts: a minimum contact current of 40 mA per contact
- When low currents are switched and not frequently, e.g. 10 mA once a day, it is advised next to gold plated contacts to put similar contacts within the same relay in parallel
- Rule of thumb: any relay works best with switching currents > 20 mA in DC environment when frequently switched. When not switched frequently a higher switching current like 50 mA is better for a long reliable operational time
- Check relays regularly and visually through the transparent cover

Instructions for use

Installation

Before installation or working on the relay: disconnect the power supply first (no hot swapping)! Install socket and connect wiring according to the terminal identification. Plug relay into the socket ensuring there is no gap between the bottom of relay and the socket. Reverse installation into the socket is not possible due to the mechanical blocking snap-lock feature. Check to ensure that the coil connection polarity is not reversed. Relays can be mounted tightly together to save space.

Warning!

- Never use silicon in the proximity of the relays
- Do not use the relay in the presence of flammable gas as the arc generated from switching could cause ignition

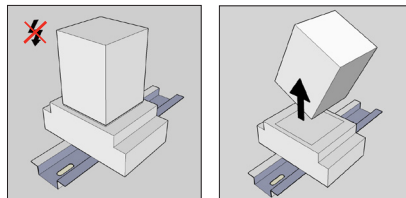

- Relays should never be swapped to other circuit positions when taken out of its socket for inspection or fault finding, always place it back into the original position to prevent contact resistance problems. Contact resistance problems can be created when swapping relays between different circuit loads due the contact wear/condition having changed during its operational life.

Operation

After installation always apply the rated voltage to the coil to check correct operation. Long term storage may corrode the silver on the relay pins. When plugging the relay into the socket, the female bifurcated or trifurcated receivers will automatically cut through the corrosion on the pins and guarantee a reliable connection.

Before actual use of relays, it is advised to switch the load several times with the contacts. The contacts will both be electrically and mechanically cleaned due to the positive wiping action. Sometimes a contact can build up increased contact resistance (≤ 15 m Ω when new). When using silver contacts one can clean the contact by switching a contact load a few times using >24 VDC & ~ 2 A. Increased contact resistance is not always problematic, as it depends on circuit conditions. In general a contact resistance of 1 Ω is no problem, consult Mors Smitt for more information.

Condensation in the relay is possible when the coil is energised (warm) and the outside, environmental temperature is cold. This is a normal phenomenon and will not affect the function of the relay. Materials in the relay have no hygroscopic properties.

Latching relay SBG

Inspection / maintenance

Correct operation of the relay can easily be checked as the transparent cover provides good visibility of the moving contacts. If the relay does not seem to operate correctly, check for presence of the appropriate coil voltage and polarity using a suitable multimeter. If a LED is fitted, it indicates voltage presence to the coil. If the relay doesn't work after inspection, replace the relay unit with a similar model. Do not attempt to open the relay cover or try to repair.

Contacts are calibrated and in balance, touching can affect proper operation. Also resoldering may affect correct operation. Since 2009 relays have tamper proof seals fitted and once broken, warranty is void.

Most relay defects are caused by installation faults such as overvoltage, spikes/transients, high/short current far exceeding the relay specifications. When returning the relays for investigation, please provide all information on the RMA form. Send defective relays back to the manufacturer for repair or replacement. Normal wear and tear or external causes are excluded from warranty.

RMA procedure see www.morssmitt.com

Latching relay

SBG

Ordering scheme

SBG							
Contact configuration	300 400						
Nominal voltage & keying		24 AL 36 CL 48 DL 72 BL 110 SY					
Coil overvoltage protection			- S				
Weld no transfer option				- C			
Manual reset control lever					- L		
Cover type						- F	

Example: SBG 300 24 AL L

Description: SB relay, 3 C/O contacts, Unom: 24 VDC, keying AL, with manual reset control lever

Latching relay
SBG

 **Over 10 million Mors Smitt relays in use in rail transport applications worldwide!**

Mors Smitt Asia Ltd.
Unit B & C, 25/F., Casey Aberdeen House
38 Heng Yip Road, Wong Chuk Hang
Hong Kong
Tel: +852 2343 555
sales.msa@wabtec.com

Mors Smitt France SAS
2 Rue de la Mandinière
72300 Sablé-sur-Sarthe, France
Tel: +33 (0) 243 92 82 00
sales.msf@wabtec.com

Mors Smitt UK Ltd.
Graycar Business Park,
Burton on Trent, DE13 8EN, UK
Tel: +44 (0)1283 357 263
sales.msuk@wabtec.com

Wabtec Netherlands B.V.
Vrieslantlaan 6,
3526 AA, Utrecht, Netherlands
Tel: +31 (0)30 288 1311
sales.msbv@wabtec.com

Mors Smitt Technologies Ltd.
1010 Johnson Drive,
Buffalo Grove, IL 60089-6918, USA
Tel: +1 847 777 6497
salesmst@wabtec.com

RMS Mors Smitt
6 Anzed Court,
Mulgrave, VIC 3170, Australia
Tel: +61 (0)3 8544 1200
sales.rms@wabtec.com

(c) Copyright 2018

All rights reserved. Nothing from this edition may be multiplied, or made public in any form or manner, either electronically, mechanically, by photocopying, recording, or in any manner, without prior written consent from Mors Smitt. This also applies to accompanying drawings and diagrams. Due to a policy of continuous development Mors Smitt reserves the right to alter the equipment specification and description outlined in this datasheet without prior notice and no part of this publication shall be deemed to be part of any contract for the equipment unless specifically referred to as an inclusion within such contract. Mors Smitt does not warrant that any of the information contained herein is complete, accurate, free from potential errors, or fit for any particular purpose. Mors Smitt does not accept any responsibility arising from any party's use of the information in this document.